

OPERATIONS RESEARCH MTH601



Virtual University of Pakistan
Knowledge beyond the boundaries

Table of Contents

1	Introduction	1
1.1	Background	1
1.2	Defining Operations Research.....	1
1.3	Management, Management Science and OR.....	2
1.4	OR Approach to Problem Solving.....	2
1.4.1	OR Process.....	2
1.5	OR is an On-going Process.....	3
1.6	Operations Research Techniques	3
1.7	Uses of OR	4
1.7.1	Macro-Economic Planning	4
1.7.2	Sectorial Planning	4
1.7.3	Micro Economic Planning	4
1.8	Potential Areas of Applications.....	4
1.8.1	Operations Research in the Public Sector.....	4
1.8.2	Operations Research in Industry & Commerce	5
1.8.3	Trucking policy for dairy products	6
1.8.4	OR in Transport	6
1.9	Example.....	6
1.9.1	Operations.....	6
1.10	Requirements for Applying Successful OR	7
1.11	Conclusion	7
1.12	Reference Texts.....	7
2	Network Analysis (PERT/CPM)	9
2.1	Introduction	9
2.2	Concept of Network	9
2.2.1	Rules for Construction of Network.....	11
2.2.2	Dummy Activities.....	11
2.2.3	Exercises	16
2.3	Finding the Critical Path.....	16
2.3.1	Algorithm for Critical Path	18
2.3.2	Early start and early finish program.....	18
2.3.3	Late start and Late finish program	19
2.3.4	Slack or Float.....	20
2.3.5	Free Slack	21
2.3.6	Independent slack	21
2.4	Pert Model	23
2.4.1	Expected length of a critical path:	24
2.4.2	Probability of completing a project with a given date	25
2.4.3	Exercise	28
2.5	Resource Scheduling in Network	28
2.5.1	Resource leveling program	29
2.5.2	Resource Allocation.....	29
2.5.3	Exercises.....	29
3	Inventory Control	31
3.1	Introduction	31
3.2	Inventory Costs.....	31
3.2.1	Item Cost (C_1).....	31
3.2.2	Purchasing or Setup or Acquisition or Ordering Cost (C_2).....	31
3.2.3	Inventory holding cost (C_3).....	31
3.2.4	Shortage Cost (C_4)	32
3.3	Inventory Models(E.O.Q. Models).....	32
3.3.1	Model-1 Purchasing model with no shortages(Wilson's model)	32

3.3.2	Model-2 (Purchasing model with shortages)	35
3.3.3	Model-3(Manufacturing model with no shortages)	40
3.3.4	Model-4 (Manufacturing model with shortages)	43
3.4	Order Quantity with Price Break	45
3.5	Exercises	45
3.6	Dynamic Order Quantity	46
3.7	ABC Analysis	47
3.8	Some Definitions	49
3.8.1	Computation of Safety Stock	49
4	Linear Programming	56
4.1	Introduction	56
4.2	Formulation of the Linear Programming Problem	56
4.2.1	Product Mix Problem	57
4.2.2	Ingredients Mixing Problem	59
4.2.3	Investment Planning Problem	61
4.2.4	Chemical Mixture Problem	63
4.2.5	Marketing Problem	64
4.2.6	Transportation Problem	66
4.3	General form of Linear Programming Problem	68
4.3.1	Exercise	69
4.4	Limitations of Linear Programming	71
4.4.1	Proportionality	71
4.4.2	Additivity	72
4.4.3	Divisibility	72
4.4.4	Deterministic	72
4.5	Solution to Linear Programming Problems	73
4.6	Graphical solution to LPP	73
4.6.1	Procedure for Graphical Solution to LPP	76
4.7	Certain Definitions	80
4.7.1	Exercise	81
4.8	Simplex Method	82
4.8.1	Simplex Procedure	83
4.9	Application of Simplex Algorithm	86
4.9.1	Step 1 (Selection of basic entering variable)	87
4.9.2	Step 2 (Selection of leaving basic variable)	87
4.9.3	Step 3 (Elimination of coefficients in the key column)	87
4.9.4	Step 4 (Further improvement of solution)	87
4.9.5	Step 5 (Stopping rule)	88
4.9.6	Exercise	89
4.10	Artificial Variable Technique	94
4.10.1	The 'Big M' Technique	94
4.10.2	The Two Phase Method	100
4.10.3	Excerice	103
4.11	Variants of Simplex Method	105
4.11.1	Minimization	105
4.11.2	Inequality in the wrong direction	106
4.11.3	Tie for the Leaving Basic Variable (Degeneracy)	106
4.11.4	Temporary Degenerate Solution	107
4.11.5	Unbounded solution	109
4.11.6	Unbounded solution space but bounded optimal solution	110
4.11.7	Multiple or Alternative optimal Solutions	112
4.11.8	Non-existing feasible solution	114
4.11.9	Unrestricted Variables	116
4.11.10	Exercise	118
4.12	Duality Theory	119
4.12.1	Dual Formulation	119

4.12.2	Constraints having equality sign	120
4.12.3	Economic Interpretation of the Dual	124
4.12.4	Applications of Duality	124
4.12.5	Excercise	125
5	Transportation Models	127
5.1	Introduction	127
5.2	Transportation Model as a Linear Programming Problem	128
5.3	Formulations of a transportation problem	129
5.4	Initial Basic Feasible Solution	129
5.4.1	North West Corner Rule	130
5.4.2	Least Cost Method	131
5.4.3	Vogel's Approximation Method (VAM)	132
5.5	Exercise	135
5.6	Moving Towards Optimality	136
5.6.1	The rationale behind optimality	136
5.6.2	Optimality test	138
5.7	VAM for maximization problem	145
5.8	Exercise	150
5.9	Degeneracy	153
5.10	Exercise	156
6	Assignment Models	158
6.1	Introduction	158
6.2	Mathematical Formulation of the Assignment Problem	158
6.3	Solution of an Assignment Problem	159
6.3.1	Multiple Solutions	161
6.4	Hungarian Algorithm	163
6.5	Maximization in Assignment Model	168
6.6	Impossible Assignment	170
6.7	Exercise	173
7	Queuing Theory	176
7.1	Introduction	176
7.2	Definitions of some important terms in Queuing Model	176
7.2.1	Customer	176
7.2.2	Server	176
7.2.3	Waiting Line or Queue	176
7.2.4	Service Channel	177
7.2.5	Arrival Rate	177
7.2.6	Service Rate	177
7.2.7	Infinite Queue	177
7.2.8	Finite Queue	177
7.2.9	Priority	177
7.2.10	Expected Number in Queue	177
7.2.11	Expected Number in System	177
7.2.12	Expected Time in Queue	177
7.2.13	Expected Number in Nonempty Queue	177
7.2.14	Expected Waiting Time For Nonempty Queue	178
7.2.15	System Utilization or Traffic Intensity	178
7.3	Single Channel Infinite-Population Model	178
7.4	Results for Poisson Arrival and Exponential Service Time	184
7.5	Exercise	188
7.6	Multi-Channel Service Infinite Queue	189
7.6.1	Exercise	191
7.7	Multi-Channel Queue with Finite Population	192
8	Replacement Models	194
8.1	Why Replacement?	194
8.2	Replacement of items with gradual deterioration	194

8.2.1	Exercise	197
8.3	Items Deteriorating with value of money	197
8.3.1	Exercise	200
8.4	Items that fail completely and suddenly	201
8.4.1	IR	201
8.4.2	IPR	201
8.4.3	CPR (Group Replacement)	201
8.4.4	Exercise	203
8.5	Staff Replacement Problem	203
9	Dynamic Programming	205
9.1	Introduction	205
9.2	Features Characterizing the Dynamic Programming Problem	207
9.3	Exercise	213
10	Miscellaneous Topics in OR.....	215
10.1	Sequencing	215
10.1.1	Processing n Jobs through Two Machines	215
10.2	Traveling Salesman Problem	215
10.3	Integer Programming	216
10.3.1	Introduction.....	216
10.3.2	Methods of Integer Programming Solution	216
10.4	Game Theory.....	217
10.5	Simulation	217
10.6	Markov Chains	218
10.7	Decision Analysis	218

1 Introduction

1.1 Background

Technology - the application of science to the everyday Physical World - has, on the whole, changed our lives greatly for the better, particularly since the time of Industrial Revolution. Manufacturing industry, which supplies us with and at the same time creates the wealth, which enables other services to exist, owes its existence to Science and Technology.

Some manufactured items, aircraft for example, are both complex and expensive, and there are great difficulties, first of all in organizing their manufacture and then, once made, in using them efficiently. Problems of this latter kind, often called systems problems, were studied rigorously for the first time by scientists, not in industry but in the management of operations in the 1939 - 45 war.

A number of teams of eminent scientists were employed by the British Government to apply their expertise to management and operational problems rather than technical problems. One such team (the Radar Operational Research team - which gave OR its name) was responsible for implementing the installation and operation of radar after the technical development work was complete.

Later on another team examined the relative ineffectiveness of the Allied Forces at destroying the German U-boats, which were sinking the food convoy ships supplying Britain. The OR team played an important part in reducing shipping losses and in the ultimate defeat of the U-boats. With no precedent in the application of Science to the management function, the scientists were still able to use their scientific approach-collecting information and developing hypothesis in order to come up with practical plans for the improvement of these wartime operations.

After the end of the war, the same approach was used with great success in the industrial and commercial field, developing most rapidly in Britain and the USA, followed by Europe and the rest of the world. This has provided the basis for the evolution of Operational Research (OR) as a separate and independent subject of Science. It is not based on any single academic engineering, social science, economics, statistics and computing but is none of these. Then what is OR?

1.2 Defining Operations Research

OR has been defined in various ways and it is perhaps too early to define it in some authoritative way. However given below are a few opinions about the definition of OR which have been changed along-with the development of the subject.

In 1946 Morse & Kimbel has defined as;

"OR is a scientific method of providing executive departments with a quantitative basis for decision regarding the operations under their control"

In 1948 Blackett defined as;

"OR is a scientific method of providing executives with any analytical and objective basis for decisions"

Another definition is due to Morse who defined in 1948 as;

"The term OR, has here-to fore been used to connote various attempts to study operations of war by scientific methods. From a more general point of view, OR can be considered to be an attempt to study those operations of modern society which involved organizations of men or men and machines".

Later on in 1957, Churchmen Ackoff and Arnoff defined;

"OR is the application of scientific methods, techniques and tools to problems involving the operations of systems so as to provide those in control of the operations with optimum solutions to the problem".

In 1958 Saaty defined OR as;

"The art of giving bad answer to problems to which, otherwise, worse answers are given".

The Operational Research Society of U.K. defines OR as:

"Operational Research is the application of the methods of science to complex problems arising in the direction and management of large systems of men, machines, materials and money in industry, business, government and defense.

The distinctive approach is to develop a scientific model of the system, incorporating measurements of factors, such as chance and risk, with which to compare the outcome of alternative decisions, strategies and controls. The purpose is to help management determine its policies and actions scientifically."

In the USA, where it is called Operations Research, the OR Society of America says more briefly; "OR is concerned with scientifically deciding how to best design and operate man-machine systems, usually under conditions requiring the allocation of scarce resources".

An even briefer definition might be "*Science applied to management*", but however, it might be defined, there is no doubt that OR provides the numerate scientist - of whatever discipline - with an opportunity to apply the skills of science in the field of Management.

Before proceeding further let us define for the sake of clarity some fundamental terms.

1.3 Management, Management Science and OR

MANAGEMENT may be equated with decision-making and control. Government ministers manage the economy industrialists make decision within their companies and individual make personal decisions.

MANAGEMENT SCIENCE is the study of problems as abstractions and the application of the resulting theory to practical situations. Its two fundamental disciplines are behavioral science and science and quantitative methods.

OPERATIONS RESEARCH (OR) is the application of quantitative methods to decision making. It formulates problems incisively and assesses the possible consequence of alternative course of action, so that informed and effective decisions can be taken.

1.4 OR Approach to Problem Solving

OR encompasses a logical systematic approach to problem solving. This approach to problem solving as shown in fig. 1 follows a generally recognized ordered set or steps: (1) observation, (2) definition of the problems, (3) model construction, (4) model solution, and (5) implementation of solution results.

1.4.1 OR Process

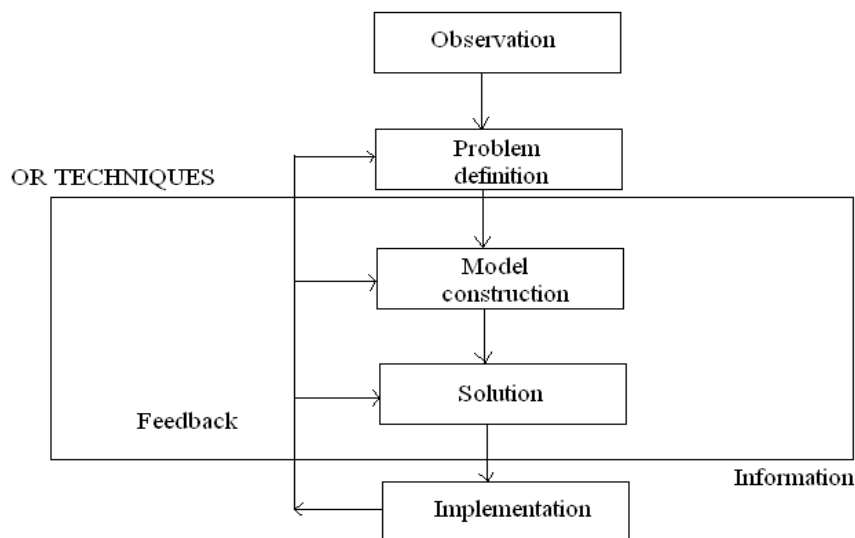

FIGURE 1

1.4.1.1 Observation

The first step in a problem solving exercises in OR is the identification of a problem that exist in the system. This requires that the system be continuously and closely observed so that problems can be identified as soon as they occur.

1.4.1.2 Definition of the Problem

Once it has determined that a problem exists, it must be clearly and concisely defined. The problem definition includes the limits of the problems and the degree to which it pervades other organs of the system. A requirement of problem definition is that the goals (or objective) must be clearly defined which helps to focus attention on what the problem is.

1.4.1.3 Model Construction

An OR model is an abstract representation of an existing problem situation. It can be in the form of a graph or chart, but mostly, an OR model consists of a set of mathematical relationship. In OR terminology, these are called objective function and constraints.

1.4.1.4 Model Solution

Once models are constructed, they are solved using the OR techniques, presented in the next section. Actually it is difficult to separate model construction and solution in most cases, since OR technique usually applies to a specific type of model. Thus, the model type and solution method are both part of the OR technique.

1.4.1.5 Implementation of Results

The results of an OR technique are information which helps in making a decision. The beauty of OR process lies in obtaining, the results which are implement able or we call it a feasible whole exercise will go waste.

1.5 OR is an On-going Process

Once the five steps described above are completed, it does not necessarily mean that OR process is completed. The model results and the decisions based on the results provide feedback to the original model. The original OR model can be modified to test different conditions and decisions that might occur in the future. The results may indicate that a different problem exists that had not been thought of previously, thus the original model is altered or reconstructed. As such, the OR process is continuous rather than simply consisting of one solution to one problem.

1.6 Operations Research Techniques

Two of the five steps of OR process, model construction and solution, encompass the actual use of OR techniques. These techniques can be loosely classified into five categories.

- 1) Linear mathematical programming technique consist of first, identifying problem as being solvable by linear programming; second formulation of unturned problem and then finding the solution by using established mathematical techniques. It derives its name from the fact that the functional relationship in the mathematical model are linear and the solution techniques consists of a predetermined mathematical steps i.e. program.
- 2) Probabilistic techniques covers those problem in which all parameters are not known with certainty. The solution results are assumed to be known with uncertainty, with probability that other solution might exist.
- 3) Inventory techniques are specifically designed for the analysis of inventory problem frequently encountered by the business firms. This particular business function is singled out for attention, since it typically represents a significant area of cost for almost every business. This category is divided into probabilistic and deterministic techniques.

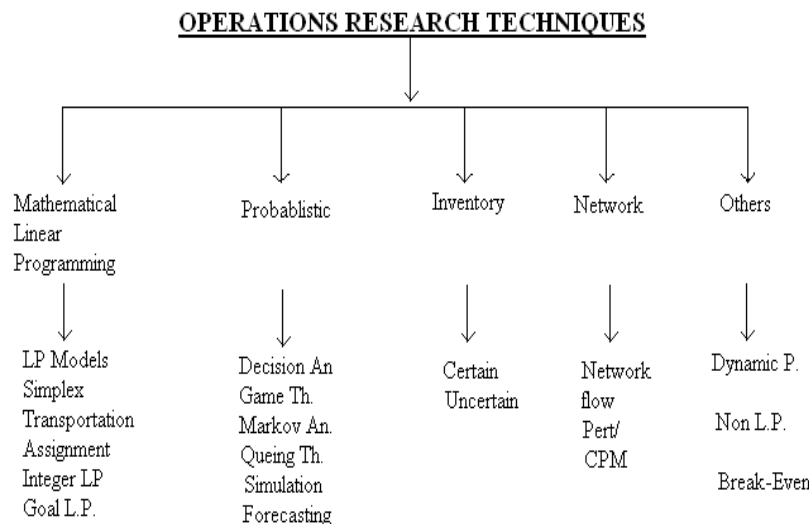

- 4) Network techniques consist of models that are represented by diagrams rather than strictly mathematical relationship i.e. pictorial representation of the system under consideration. These models can represent either probabilistic or deterministic systems.

5) Other techniques consist of all the remaining techniques, which do not come under the four heads mentioned above. For example, Dynamic programming employs a different modeling and solution logic than linear programming. In non-linear programming either the objective function or the constraints or both can be non-linear functions, which would require altogether different solution technique.

1.7 Uses of OR

In its recent years of organized development, OR has entered successfully many different areas of research for military government and industry in many countries of the world. The basic problem in most of the developing countries in Asia and Africa is to remove poverty and improve the standard of living of a common man as quickly as possible. So there is a great scope for economists, statisticians, administrators, politicians and the technicians working in a team to solve this problem by an OR approach. The possible application sectors, in Pakistan, are as under:-

1.7.1 Macro-Economic Planning

OR can be employed for Macro-Economic Planning of the country:

- a) Input / Output Analysis: by using LP models. This input/output analysis can be of any duration [i.e. of short term (up to say 10 years)-Five Year Plan; and of long term (10-30 years)].
- b) Investment Planning: OR can be employed in the Investment Planning of the country where investment plans for the next five or ten years are prepared. Mixed Integer Programming and Linear Programming techniques can be used.
- c) Choice of Projects: OR can help the people in the planning in choosing the optimal project. This sort of choice would need Integer Programming and Quadratic Assignment techniques.
- d) OR can also be used in Simulation Modeling of the Economy of the country.

1.7.2 Sectorial Planning

OR can also be employed in a particular sector of the Economy, e.g. in agriculture, in finance, in industry, in marketing, in production, in management etc.

- a) Scheduling all operations within a sector can be done by using OR e.g. production scheduling + Distribution planning + marketing + Personnel management + maintenance +
- b) Schedule of some operations within a sector can be done by employing OR e.g. Inventory planning in agriculture or distribution of fertilizer etc.

1.7.3 Micro Economic Planning

This sort of activity involve for example:
 Planning the operations of a Company.
 Improving the layout of a workshop in a company.

Finding size of a hospital in an area etc.

There is a great potential for utilizing OR in this area of planning in our country.

1.8 Potential Areas of Applications

As mentioned earlier OR can be applied in every field of life. Here are few of the many fields where OR has potential application. This list is by no means comprehensive or exhaustive but definitely will provide an idea of the power of OR as a separate discipline.

1.8.1 Operations Research in the Public Sector

1.8.1.1 Federal, Provincial and Local Government

Development of Country Structure Plans
 Manpower Planning and Career Development in Govt. Departments
 Organization of Long-Term planning groups at the National Level
 Corporate Planning in Local Government
 Allocation of Government Houses
 Estimation of Future Requirement of School/College Building
 Placing of Fire Brigade in a City

Measuring the Effectiveness of Police
 Timetabling in Schools and Colleges for Efficient use of Space

1.8.1.2 Health

Management policies for 120-bed nursing units
 Optimum size of general hospitals
 Appointment systems for hospital outpatients
 Stock control for regional and area health units
 National and area planning of health services
 Manpower planning for nurses, radiographers, etc.
 Commissioning of a new general hospital
 Simulation of pathology laboratories
 Organizing an ambulance service
 Care provided by community nurses

1.8.1.3 Defense

Arms control and disarmament studies
 Communications network development
 Logistic support in operations
 Field experimentation
 War games and other models of battle
 Equipment procurement
 Reinforcement and redeployment problems

1.8.2 Operations Research in Industry & Commerce

1.8.2.1 Finance and Investment

Developing the five-year plan for a food manufacturer
 Development of the pipeline
 Computer based financial planning
 Portfolio selection
 Structure for the assets of a bank
 Evaluating investment in a new plant
 Corporate planning in the chemical industry
 Financing expansion of a small firm

1.8.2.2 Production

Production scheduling in a steel works
 Meeting peak demands for electricity
 Minimization of costs of power station maintenance
 Scheduling newsprint deliveries
 Stock levels of steel plate
 Meeting seasonal demands for products
 Blending scrap metals
 Stock policy for a paint manufacturer
 Allowing for yarn breaks in spinning
 Meeting customer requirements for carpets
 Planning a quarry's output
 Optimum layout for belt coal transport in a colliery

1.8.2.3 Marketing

Launching a new product
 Advertising effectiveness and cost
 Planning sales territories
 Measurement of consumer loyalty
 Buyer-seller behavior
 Advertising research and media scheduling
 Most profitable retail brand mix
 Developing customer service policies
 Pricing policies for confectionery

1.8.2.4 Personnel

Personnel shift planning
 Manpower planning
 Manpower for an assembly line
 Effects of flexible working hours

1.8.2.5 Distribution

Distribution of Products.
 Returnable bottles: how many?
 Refinery crude tank capacity
 Depot location of pharmaceutical products

1.8.3 Trucking policy for dairy products

Distribution of newspapers to newsagents

1.8.4 OR in Transport**1.8.4.1 Rail**

Rail freight management
 Required fleet size of locomotives and rolling stock
 Forecasting passenger traffic
 Planning reconstruction of main-line termini
 Introduction of freightliners

1.8.4.2 Road

Designing urban road networks
 Forecasts of car ownership
 Implementation of bus lanes
 Re-routing bus services
 Purchasing and maintenance of buses
 Introduction of flat-fare buses
 Bus services in rural areas
 Preparation of crew rosters

1.8.4.3 Air

Planning the introduction of Boeing 737/Airbus 300
 Allocation of aircraft and crew to routes
 Location of Islamabad Airport
 Karachi-Lahore - Islamabad - Peshawar: aircraft requirements

1.8.4.4 Sea

Potential traffic for new container services
 Shipbuilding requirement in the 1990's
 Optimum ship size for given routes
 Construction and management of a container terminal

1.9 Example

Before proceeding further let us take an example, which will help to understand the scope of application in various activities. Given below are some of the major activities :

1.9.1 Operations

- 1) Oil production from fields
- 2) Transportation of Crude
 - from fields to refineries
 - from fields to export ports (Jetties)
 - from import ports (Jetties) to refineries
- 3) Storage of Crude
 - on fields
 - at Ports
 - at refineries
- 4) Refinery Scheduling
 - Operation of CDU's

- 5) Storage of Distilled Blended Products
 - Operation of Blending Units
 - at refineries
 - at Jetties
 - at distribution points
- 6) Transportation of Products
 - from Jetties to refineries
 - from one refinery to another for another processing
 - from refinery to bulk distribution pts.
 - from bulk distribution points to final consumers.

At all the stages from oil production from fields to its transportation to the final consumer OR has been employed in the developed countries of the world. Applying on macro level is not an easy job. This would require true and factual data computing power and trained professionals, and perhaps at this stage we may face some problem due to limited resources in term of manpower, money and machines, but it does not mean that we should not make a beginning.

1.10 Requirements for Applying Successful OR

In order to apply OR successfully in achieving certain objectives the following are some of the prerequisites:

- 1) Sufficient number of qualified OR personnel should be available who should know the art of selling OR. These professional should be ready to work in close cooperation with staff at various levels of the organization because they have to dig out the problem from the grass roots.
- 2) Normally, there is a tendency of management to give false information, in order to create a better image, and sometime there may be a lack of adequate communication between OR practitioner and management. To meet these circumstances there should be a healthy interaction with the statistical machinery so as to enhance the quality and availability of data.
- 3) Satisfactory power of computer machinery along with associated support should be available so as to analyze the data and forecast correctly. For this management should be aware of modern techniques and tools of management.
- 4) Last but not the least management should be ready to accept the change and be enthusiastic to know the correct alternatives.

1.11 Conclusion

In the proceeding paras we traced briefly the history of OR; defined OR, and its process; elaborated various techniques of OR; identified various areas of application and requirements for successfully applying OR. Before concluding it will be most appropriate to quote Stafford Beer, the famous OR Scientists.

"We call that work operational (with a large O) because it is based in the world of genuine activity, the places where things actually happen. All good sciences, as distinguished from all mysticism is found in empiricism. It involves actual observation, actual measurement and actual experiment."

We call our work Research (with a capital R) because we deal with problems to which no one knows the answer.

"Doing that thing is called RESEARCH!"

Finally I would say,

"We need OR teams of outstanding abilities, working on problems of decision & control at the National Level. Because these problems are usually discussed in economic terms, they are currently assumed to be purely economic problems."

BUT THEY ARE NOT

"Interdisciplinary Scientific teams are needed to evaluate issues subject to conflicting criteria."

1.12 Reference Texts

- Bellman, Richard E. Dynamic Programming. Princeton University. Press
 Gale, David, The Theory of Linear Economic Models. McGraw-Hill
 Hadley, G., Linear Programming. Addison Wesley
 Ackoff, R. L., and P. Rivett, A Manager's Guide to Operations Research, Wiley
 Dantzig, George B., Linear Programming and Extensions, Princeton University Press
 Hadley, G., Nonlinear and Dynamic Programming, Addison Wesley
 Ackoff, Russell L., and Maurice W. Sasieni, Fundamentals of Operations Research, Wiley
 Beale, E. M. L., Ed. Applications of Mathematical Programming Techniques. English University. Press

Rivett, P., Principles of Model Building, Wiley

Wagner, Harvey M. Principles of Operations Research, Prentice-Hall

Taha, Hamdy A., Operations Research: An Introduction, Macmillan

Ignizio, J.P., Linear Programming in Single and Multiple Objective Systems. Prentice-Hall

2 Network Analysis (PERT/CPM)

2.1 Introduction

PERT is an acronym for "Program Evaluation and Review Technique". This was created as a means to plan and accelerate the development of the Polaris Ballistic Missile. In USA the defence department developed a nuclear missile to be launched from beneath the ocean's surface by a mobile submarine, which would be an effective deterrent against aggression by an enemy. This paved way to plan how to design, develop and plan the different stages in the production of a missile and how quickly this task could be completed. A planning and scheduling technique named PERT gave the answer to these questions.

In any new venture, uncertainties are bound to creep in. PERT incorporated these uncertainties into a model, which provides a reasonable answer to these uncertainties. There are certain statistical aspects scheduling large projects consisting of numerous activities whose completion times are uncertain and are independent of one another. PERT is an event-oriented technique. By 'event' we mean reaching a certain stage of completion of the project.

Another technique, Critical Path Method, abbreviated as CPM, has emerged simultaneously. It is also a network technique but it is concerned with obtaining the trade-off, between cost and completion date for large projects. In any project consisting of several activities each activity can be completed in a normal duration with normal cost. If we employ more persons or skilled people or given overtime to the workers, the activity could be completed in a reduced duration known as crash duration. But this involves an increased cost in the form of additional resources. With CPM the amount needed to complete the various activities is assumed to be known with certainty. So, the direct costs for the activities increase and hence the cost of the project also increases. By reducing the activity duration of some or all possible completed ahead of the schedule. This will naturally reduce the overhead cost for the entire project. On one hand the direct expenses increase, if we shorten the activity duration, but, the indirect expenses for the project are reduced. We have to strike a balance or an optimum time schedule, or a least cost schedule is to be obtained. This is the purpose of the Critical Path Method. Thus CPM is not concerned with uncertain job times as in PERT. PERT is useful in research and developmental projects, whereas CPM is mostly used in construction projects, or in situations already handled, so that the details like the normal completion time, crash duration and cost of crashing are already known.

The following are the suggested applications when PERT or CPM is found useful.

- The construction of a building or of a highway.
- Planning and launching a new product.
- Scheduling maintenance for a project.
- The manufacture and assembly of a large machine tool.
- To conduct a music or drama festival.
- Preparation of budget for a company.

2.2 Concept of Network

The first step in the application of CPM / PERT is to develop a network representation of the project plan.

A 'network' is defined as a graphic representation with a flow of some type in its branches. It represents nodes and branches. Below in table 1, we represent different systems satisfying the definition of network in the physical world.

Table 5.1

Physical situation	Nodes	Branches	Flow
Highway systems	Intersections	Roads	Vehicles
Communication	Switching points	Wires	Messages

systems			
Fluid supply systems	Pumping stations	Pipes	Fluid
Production systems	Work centres	Handling routes	Jobs
Project Management	Decision points	Activities	Time
Airway systems	Airports	Airlines	Aircraft

A node is the intersection of the two branch lines. It is denoted by a circle. Each branch represents an activity. Each node represents an event, which is a specific definable accomplishment recognizable at a particular instant of time. The arrowheads indicate the sequence in which events must be achieved. Thus an event is the completion of all the activities leading into that node and this event must precede the initiation of the activity leading out of the node.

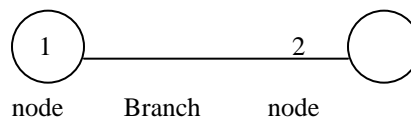

Fig. 1

An arrow diagram represents a project graph. An arrow connecting two nodes, representing two events, represents each activity. The head of the arrow identifies the start of the activity. Let us take an example and illustrate the construction of arrow diagram for a project.

Example 1

A company is interested in preparing a budget. The details of the activities and the departments involved are given in the Table 2.

Table 2

The project of preparation of a Production budget.

Job Identification	Alternate	Job Description	Department
A	1-2	Forecasting sales	Sales
B	2-4	Pricing Sales	Sales
C	2-3	Preparing production Schedule	Engineering
D	3-4	Costing the production	Costing
E	4-5	Preparation of budget	President

The project of budgeting can be displayed in a network or project graph by an arrow diagram. Jobs are shown as arrows leading from one node to the other as in Figure 2.

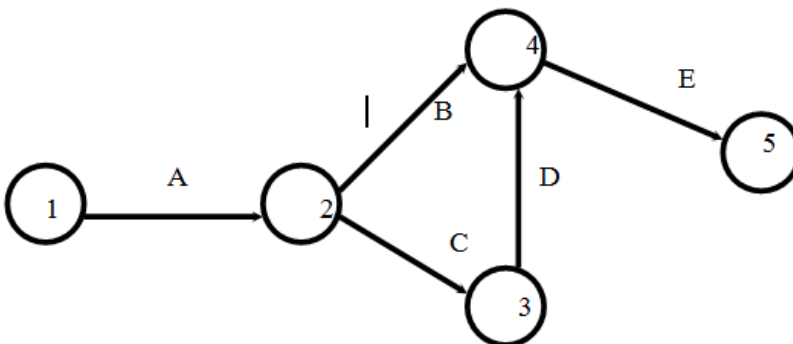

Fig. 2

From the arrow diagram 2, we infer that activity A is the first job. Jobs B and C start only after A is over. A is called the predecessor of B and C and B and C the successors of A.

2.2.1 Rules for Construction of Network

- (a) Each activity is represented by one and only one arrow. This means that no single activity can be represented twice in a network.
- (b) No two activities can be identified by the same end events. This means that there should not be loops in the network.
- (c) Time follows from left to right. All the arrows point in one direction. Arrows pointing in opposite direction must be avoided.
- (d) Arrows should not cross each other.
- (e) Every node must have at least one activity preceding it and at least one activity following it, except for the nodes at the very beginning and at the very end of the network.

2.2.2 Dummy Activities

There is a need for dummy activities when the project contains groups of two or more jobs which have common predecessors. The time taken for the dummy activities is zero.

Suppose we have the following project of jobs with their immediate predecessors.

Jobs	Immediate predecessors
A	-
B	-
C	-
D	A, B
E	B, C

Activity B is the common immediate predecessor of both D and E. A is the immediate predecessor of D alone and C is the predecessor of E. Let B lead into two dummy jobs D₁ and D₂ and let D₁ be an immediate predecessor of D and D₂ of E as shown in Figure 3.

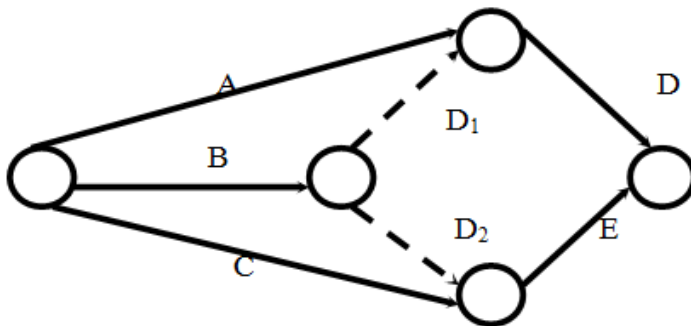

Fig. 3

Dummy arrow represents an activity with zero time duration. It is represented by a dotted line and is introduced in a network to clarify activity pattern under the following situations.

- (i) It is created to make activities with common starting and finishing events distinguishable.
- (ii) To identify and maintain the proper precedence relationship between activities those are not connected by events.

Consider an example where A and B are parallel (concurrent activities). C is dependent on A and D is dependent on both A and B. Such a situation can be represented easily by use of dummy activity as shown in Figure 4.

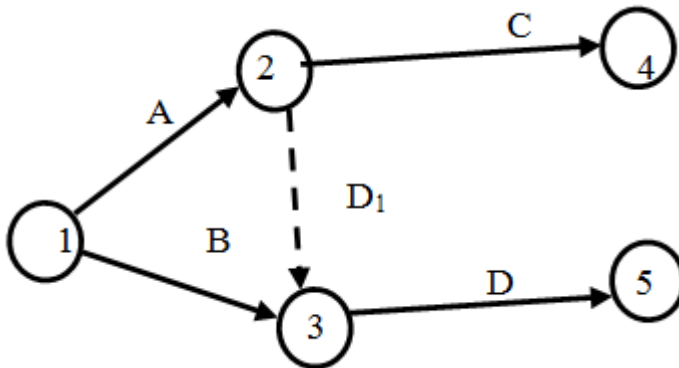

Fig. 4

Example 2

A project consists of the following activities whose precedence relationship is given below. Draw an arrow diagram to represent the project.

Activity	Followed by	Preceded by
A	B, C	-
B	D	C, A
C	E, B	A
D	F	B
E	G, F	C
F	H	E, D
G	H, I	E
H	I	G, F
I	-	G, H

Solution

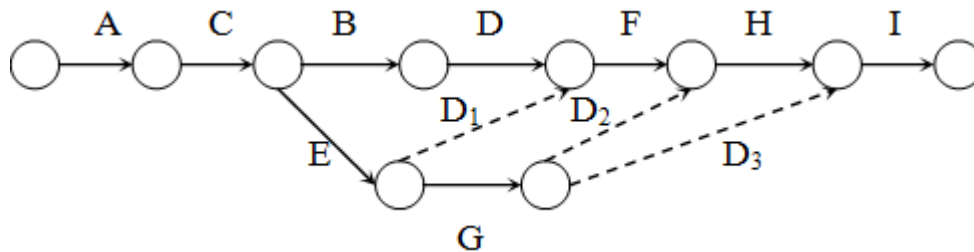

Fig. 5

Example Consider the following project. Draw an arrow diagram to represent the project.

Activity	A	B	C	D	F	G	H	I
Precedence	-	-	A	A	B, C	F	B,C,D	H,G

Solution:

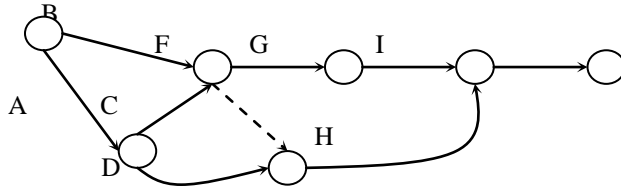

Fig. 6

Example Consider the project of building a house. The details of the project activities are tabulated below. Draw network.

Activity	A	B	C	D	E	F	G	H	I	J	K
Immediate Predecessor	-	A	-	B,C	C	G,H	D	B	F	G	E,I,J

Solution:

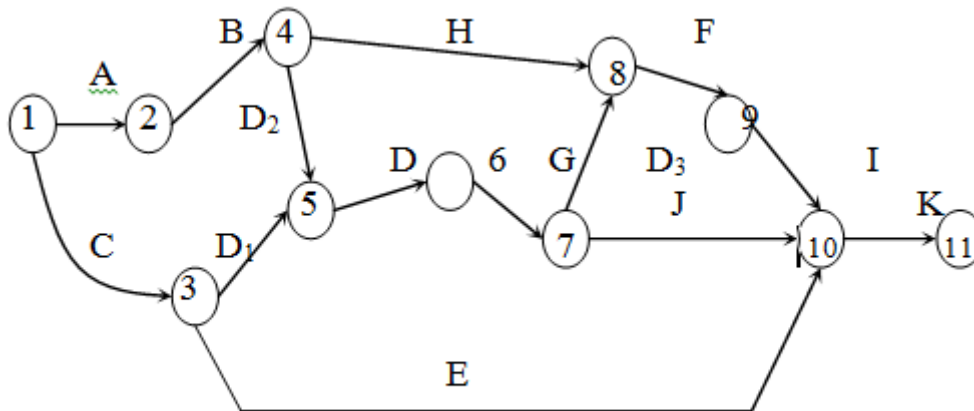

Fig. 7

Example A project has the following activities. The relationships among the activities are given below. Construct the network.

- A is the first operation.
- B and C can be performed parallel and are immediate successors to A.
- D,E and F follow B.
- G follows E.
- H follows D, but it cannot start till E is complete.
- I and J succeed G.
- F and J precede K.
- H and I precede L.
- M succeeds L and K.
- The last operation N succeeds M and C.

Solution:

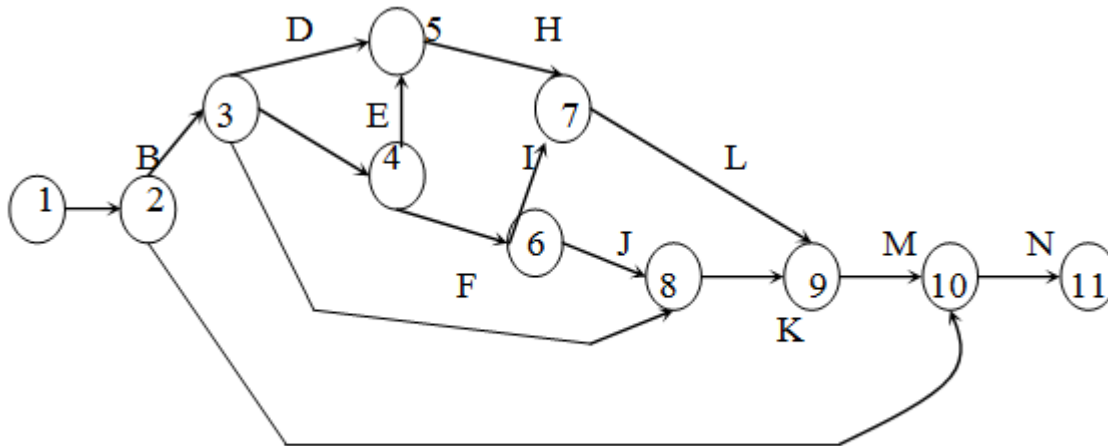

Fig. 8

Example

Activity	A	B	C	D	E	F	G	H	I	J	K	L
Predecessor	-	-	A	A	B	B	C,D	E	C,D	G,H	F	J,K

Solution:

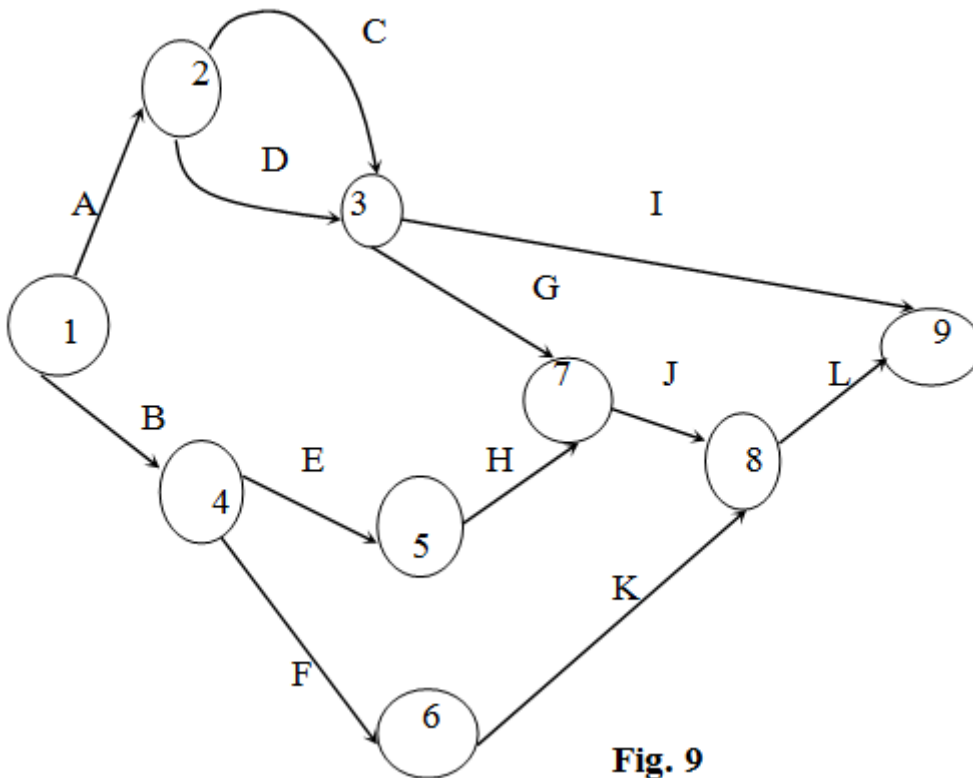

Fig. 9

Example Draw network from the following list of activities.

Job Name	Immediate predecessor	Job Name	Immediate predecessor
a	-	l	k
b	a	m	k

c	b	n	k
d	c	o	d
e	b	p	o
f	e	q	b
g	e	r	n
h	c	s	l, m
i	c, f	t	s
j	g, h, i	u	p, q
k	j	v	u

Solution:

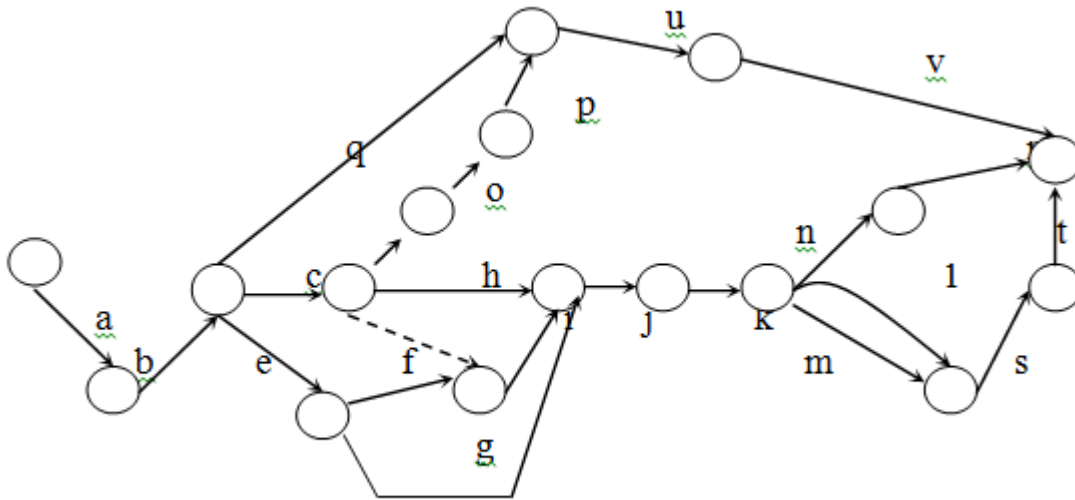

Fig. 10

Example For a project of 12 activities the details are given below. Draw PERT network.

Activity	A	B	C	D	E	F	G	H	I	J	K	L
Dependence	-	-	-	B,C	A	C	E	E	D,F,H	E	I,J	G

Solution:

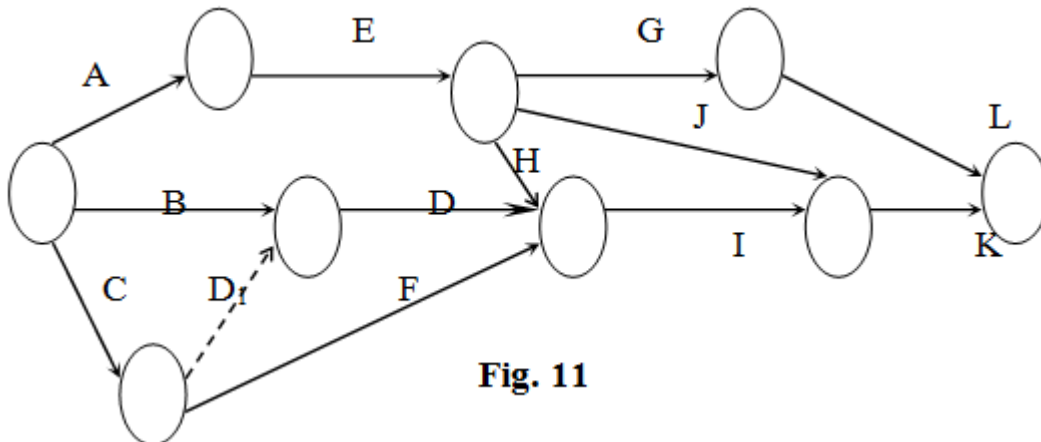

Fig. 11

2.2.3 Exercises

1. (a) Explain in brief PERT, CPM and dummy activities with reference to Project Management.
- (b) The following information is known for a project. Draw the network and find the critical path. Capital letters denote activities and the numbers in bracket denote activities' time.

This must be completed	before	This starts
A(30)		C
B(7)		D
B		G
B		K
C(10)		D
C		G
D(14)		E
E(10)		F
F(7)		H
F		I
F		L
F		I
G(21)		L
H(7)		J(15)
I(12)		J
K(30)		L(15)

2. Draw network diagram for the following activities whose predecessors are given in the table below.

Job	A	B	C	D	E	F	G	H	I	J	K
Immediate Predecessors	-	A	B	C	B	E	D,F	E	H	G,I	J

2.3 Finding the Critical Path

After listing all the activities with their precedence relationship we project these activities in a project graph represented by arrows or Activity On Node diagram (AON). Now we have to find the minimum time required for completion of the entire project. For this we must find the longest path with the sequence of connected activities through the network. This is called the critical path of the network and its length determines the time for completion of the project. The activities in the critical path are so critical that, if they are delayed, the project completion date cannot be met and the project finish time will have to be extended. We shall now see how to identify the critical path, the critical activities and the duration of the project. The meaning of path and length of a path should first be made clear. Let us take following example.

Consider the following network shown in figure 12.

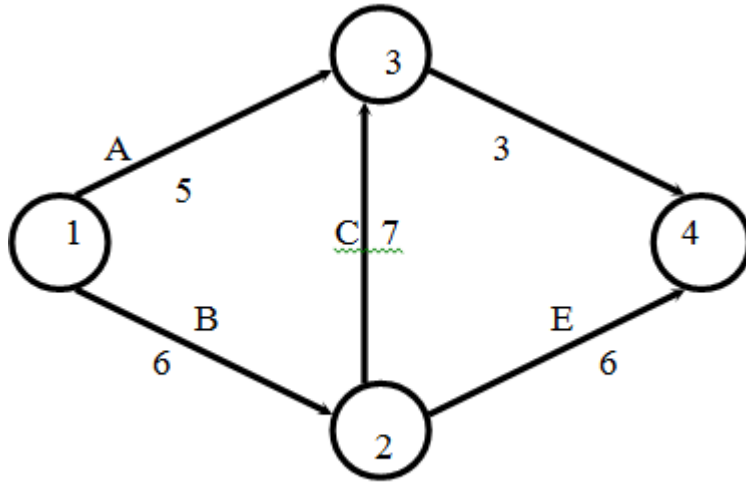

Fig. 12

We have five activities A, B, C, D and E with the time of completion of the activities 5, 6, 7, 3 and 6 days respectively. We represent the activities in a network shown in the same figure.

In this network, there are three ways to get from the starting point at node 1 and travel through the network to end at node 4. These ways are called paths. Thus, a path is defined as "a set of nodes connected by lines which begin at the initial node of a network and end at the terminal node". In figure12, there are three paths namely, 1-3-4, 1-2-3-4 and 1-2-4 where the numbers represent the nodes. The length of a path in a network is the total time it takes to travel along the path. This time is calculated by adding the individual times between the connected nodes on the path. A path is called a critical path if it is the longest the path in a project network. We have the times of the three distinct paths has shown below.

Path	Time (days)
1-3-4	$5 + 3 = 8$ days
1-2-3-4	$6 + 7 + 3 = 16$
1-2-4	$6 + 6 = 12$

The path connecting the nodes 1,2,3 and 4 constitutes the longest path and hence 1-2-3-4 is the critical path. The minimum time to complete the project is the time taken for the longest path namely 16 days. The activities B (1-2), C (2-3) and D(3-4) constitute the critical activities. These jobs are critical in determining the project's duration. The critical path for the above example can be shown in the diagram.

The same can be calculated using Activity On Node diagram. The AON diagram is as shown in figure 13.

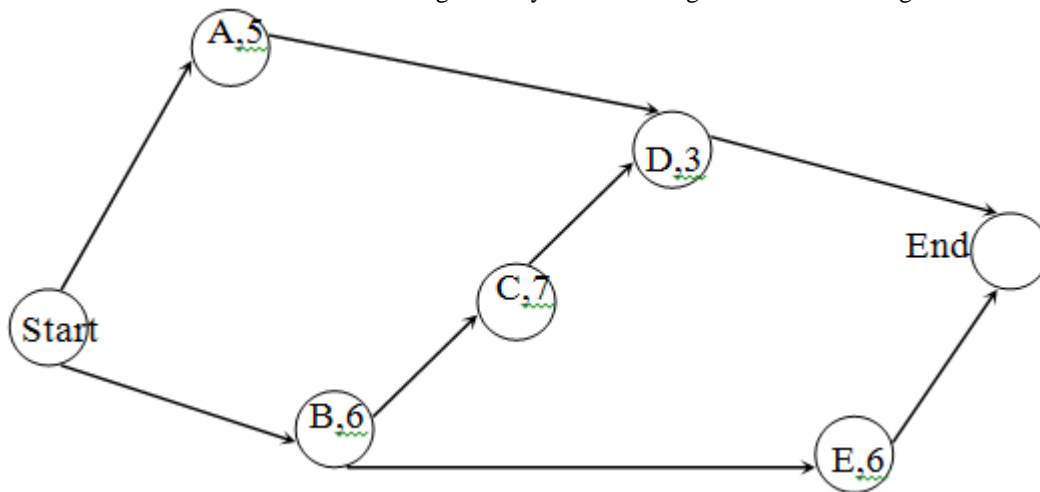

We see that there are three paths or routes from start to end.

The following are the paths.

- (1) Start - A - D - End
- (2) Start - B - C - D - End
- (3) Start - B - E - End.

The times taken to complete the activities on the three paths are

$$\begin{aligned}
 5 + 3 &= 8 \text{ days} \\
 6 + 7 + 3 &= 16 \text{ days} \\
 6 + 6 &= 12 \text{ days}
 \end{aligned}$$

The longest path is B-C-D and the duration is 16 days. Hence the critical path is B-C-D and the project completion time is 16 days.

Thus, whether we use the arrow diagram or the activity on node diagram, we get the same result. This procedure can be applied without much effort for small projects involving only a few activities but the same procedure may be cumbersome if the project involves a large number of activities. However, there is an effective method of finding the critical path as explained in the next section.

2.3.1 Algorithm for Critical Path

Consider the following project.

Job's name	Immediate predecessor	Time to complete the job
a	-	10 days
b	-	3 days
c	a,b	4 days
d	a	7 days
e	d	4 days
f	c,e	12 days

We draw the project graph by an arrow diagram as shown in Fig 14. The activity 'g' is a dummy activity consuming no time.

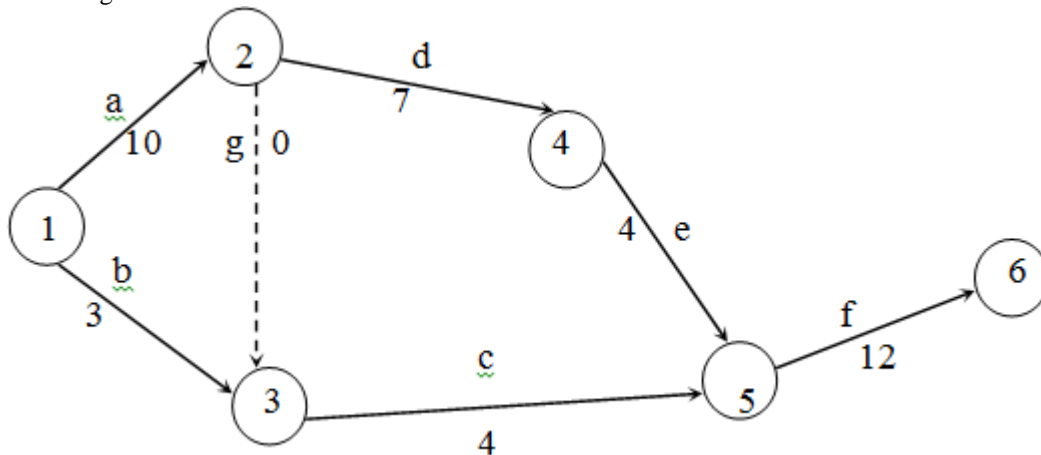

2.3.2 Early start and early finish program

We define the 'early start' of a job in a project as the earliest possible time when the job can begin. This is the first number in the bracket. The early finish time of a job is its early start time plus the time required to perform the job. We put this as the second number in the same bracket. Thus if in fig. 15 the early start of the job a will be 0 as this is the first job. The early finish $0 + 10 = 10$. For convenience we denote the start time of a project as 0. So we

have early start and early finish times as (0, 10) for job a. For job b, the early start time will also start and the early finish times are (0, 3). The jobs d and g can start, at the earliest, as soon as the job a is completed, because 'a' is the predecessor for d and g. Hence the early start time for job d will be 10 and early finish time for job d will be $10 + 7 = 17$. For the job g the early start and early finish will (10, 10) since g happened to be a dummy job. Next we take the job c which has two predecessors namely b and g. The job c can be started, at the earliest on 10. So the job c can start, at the earliest only on 10 and the early finish of the job c will be $10 + 4 = 14$. Similarly the early start of job e is 17 and finish is $17 + 4 = 21$. The job f has two predecessors namely c and e, c is finished at the earliest on 14 and e on 21. So, the job f can start at the earliest only on 21 and finished at the earliest on 33.

All the above data are recorded as shown in figure 15.

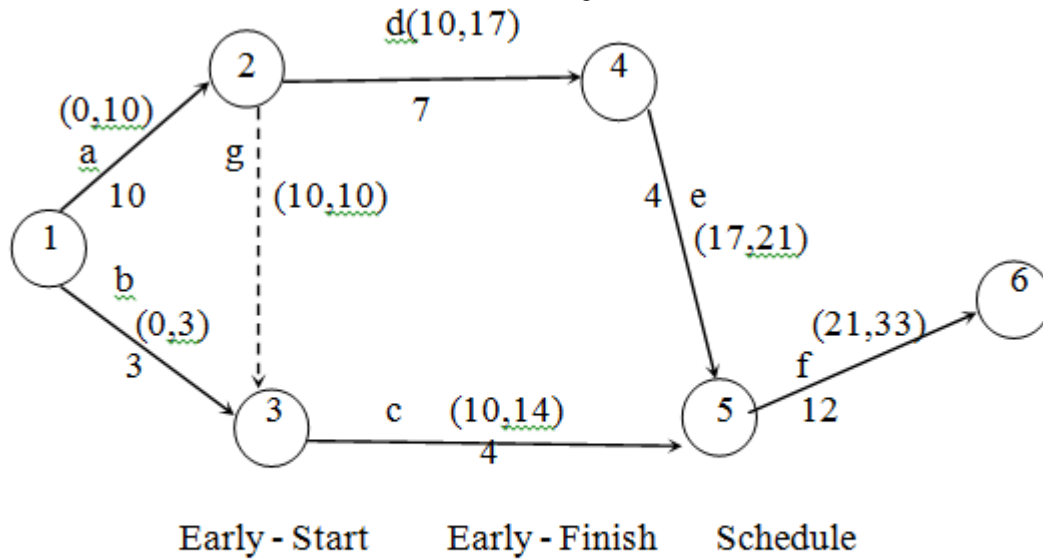

Fig. 15

Thus the project can be completed in 33 days. If the earliest completion time of the project is 33 days after it has begun, the longest path through the network must be 33 days in length. When we compare the alternate paths available for completion of the project (a-d-e-f = 33; a-g-c-f = 26; b-c-f = 19) from the beginning to the end we will find that the critical path is 33 days, with the jobs a, d, e, f on the critical path.

2.3.3 Late start and Late finish program

The activities not on the critical path can be delayed without delaying the completion date of the project. A normal question may arise at this juncture as to how much delay can be allowed for non-critical jobs. How late can a particular activity be started and still maintain the length of the project duration? For answering these questions we find the late start and late finish times for each activity in the project graph.

We define the late start of an activity as the latest time that it can begin without pushing the finish date of the project further into the future. Similarly late finish of an activity is the late start time plus the activity duration.

We have seen that the early start and early finish time of activities are calculated in the forward direction from left to right. To calculate the late start and late finish times, we begin at the end of the network and work backwards. In the example cited above we begin with the node 6. The job leading to the node is job f. It must be completed by day 33 so as not to delay the project. Therefore, day 33 is the latest finish. In general duration of the critical path will be taken as the late finish time of the project.

The time taken for the activity f is 12 days, so that it must begin at day 21 and end on 33. Thus the late start of the activity f is day 21.

We represent the late start and late finish times of the activity f within brackets (21, 33) in figure 16. The job f has two predecessors namely c and e. The late-finish times for both jobs can be taken as day 21. If this is so, c's

late start will be 21-4 or day 17 and e's late start will be 21-4 or day 17. We can record the late start and late finish times jobs c and e in the figure within brackets.

Now, the job d is the only predecessor to e and d can finish as late as day 17 which is the late start of e, so d can start as late as on day 10. Coming to the activity g, which is the predecessor to c, the late finish time of job g is the same as late start time of c. So late start and late finish time of g will be (17, 17). Since b precedes c, b also can finish as late as on day 17 and start as late as on day 14.

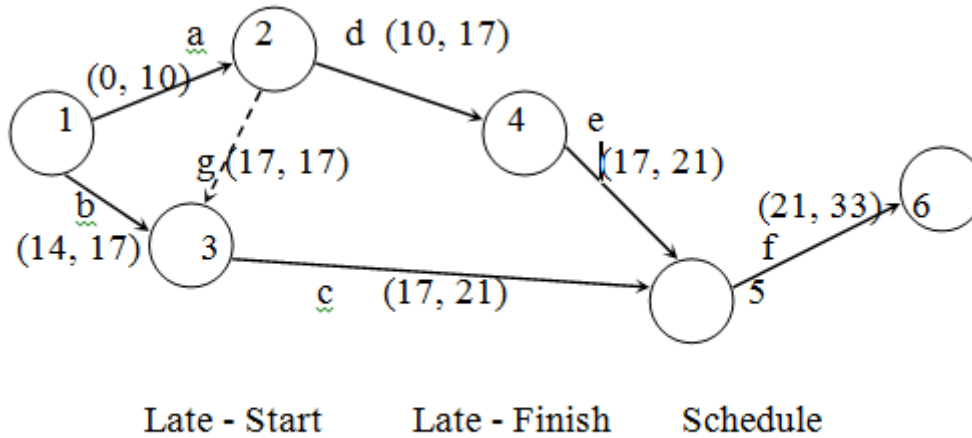

Fig. 16

Next we take job a, which has two successors namely d and g, which have days 10 and 17 as the late start times respectively. So the job a must finish as late as on day 10 in order that a can be made to start on day 10. The finish time of the activity a will be least of the late start time of the successor activities. Hence the late finish of the activity a must be day 10 and it starts on day 0. This is also shown figure 16.

The above information of early start-early finish programme and late start-late finish programmes is very useful as we shall see next.

2.3.4 Slack or Float

In the figure 15 and figure 16 which represent the early start-early finish and late start-late finish programmes, we observe that the late start and early start times are identical for some jobs. (Similarly late and early finish times). For example for the job a, the early and late start time is 0, for the job d, early and late start time is 10, for e they are 17 and for f also they are 21, whereas for job b the early start is day 0 and late start is day 14. This indicates that the job b can start as early as day 0 or as late as on day 14, without delaying the project completion date of 33 days. This difference between late start of the job and the early start of the same job is called as 'slack' or 'float'. It is also termed as 'total slack' or 'total float'. This denotes the maximum delay that can be allowed for this job. Similarly for job g, the early start time is day 10 and late start time is 17. There is a difference of 7 days which is the slack for job 'g'. Similarly we have a slack of 7 days for the job 'c' also.

The jobs having no slack thus become critical and the jobs with slacks are non-critical. So if we connect the jobs having no slacks, we get the critical path. This is the method of finding the critical path. In the example the jobs a, d, e, f have no slack and the path connecting a, d, e and f or 1-2-4-5-6 becomes the critical path.

We can summaries the slack for all jobs given in the tabular below.

Jobs	Early start	Early finish	Late start	Late finish	Slack
a	0	10	0	10	0
b	0	3	14	17	14

c	10	14	17	21	0
d	10	17	10	17	0
e	17	21	17	21	0
f	21	33	21	33	0
g	10	10	17	17	7

This critical path is shown in figure 17

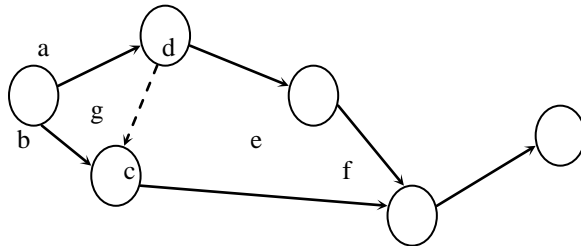

Fig. 17

2.3.5 Free Slack

Free Slack is defined as the amount of time an activity can be delayed without affecting the early start time of any other job. In other words, the free slack of any activity is the difference between its early finish time and the earliest of the early start times of all its immediate successors. In the example above, if we take the activity b, its early finish time is day 3 and its immediate successor c starts at the earliest on day 10. 'c' can start as late as on day 17, but there is not compulsion on c to start exactly on day 10. If he chooses to start on day 10 (earliest start time) ten b will b\have only 7 days as free slack (difference between early start of c and early finish of b). Similarly for the job c also we have free slack as the difference between the early finish of c and early start of its immediate successor 'f' i.e. 21-14 = 7 days. Free slack can never exceed total slack. The total slack and free slack for all activities are given in the following table.

Activity	Total Slack	Free Slack
a	0	0
b	14	7
g	7	0
c	0	7
d	0	0
e	0	0
f	7	0

2.3.6 Independent slack

It is that portion of the total float within which an activity can be delayed for start without affecting slacks of the preceding activities. It is computed by subtracting the tail event slack from the free float. If the result is negative it is taken as zero.

Example The following table gives the activities of a construction project and duration.

Activity	1-2	1-3	2-3	2-4	3-4	4-5
Duration (days)	20	25	10	12	6	10

- (i) Draw the network for the project.
- (ii) Find the critical path.

(iii) Find the total, free and independent floats each activity.

Solution: The first step is to draw the network and fix early start and early finish schedule and then late start-late finish schedule as in figure 18 and figure 19.

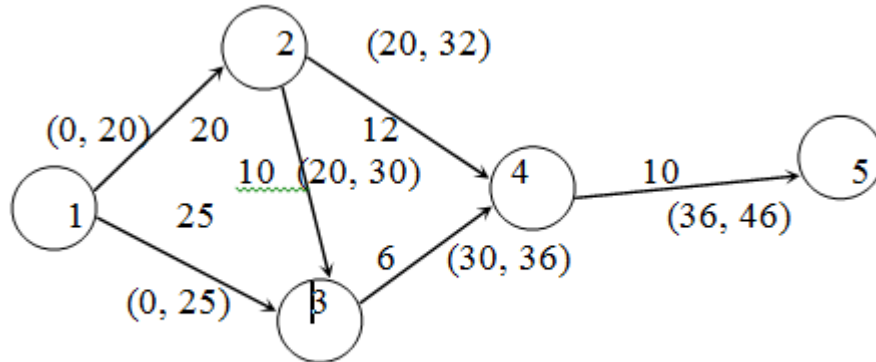

Early-Start Early-Finish Schedule

Fig. 18

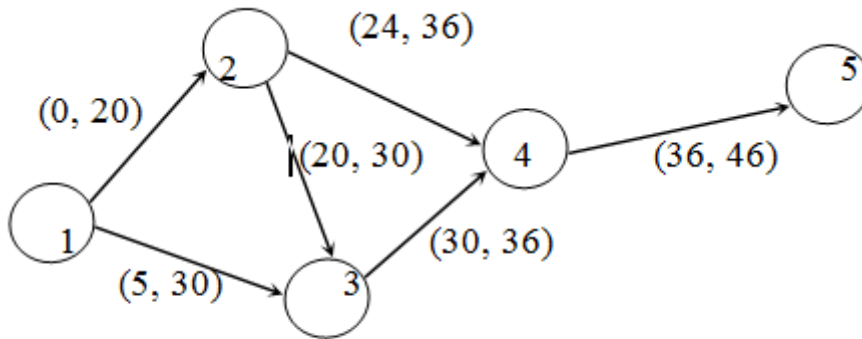

Late-Start Late-Finish Schedule

Fig. 19

Activity	Total Slack	Free Slack	Independent Slack
1-2	0	0	0
1-3	5	5	5
2-3	0	0	0
2-4	4	4	4
3-4	0	0	0
4-5	0	0	0

To find the critical path, connect activities with 0 total slack and we get 1-2-3-4-5 as the critical path.

Check with alternate paths.

$$\begin{aligned}
 1-2-4-5 &= 42 \\
 1-2-3-4-5 &= 46^* \quad (\text{critical path}) \\
 1-3-4-5 &= 41
 \end{aligned}$$

2.4 Pert Model

PERT was developed for the purpose of solving problems in aerospace industries, particularly in research and development programmes. These programmes are subject to frequent changes and as such the time taken to complete various activities are not certain, and they are changing and non-standard. This element of uncertainty is being specifically taken into account by PERT. It assumes that the activities and their network configuration have been well defined, but it allows for uncertainties in activity times. Thus the activity time becomes a random variable. If we ask an engineer, or a foreman or a worker to give a time estimate to complete a particular task, he will at once give the most probable time required to perform the activity. This time is the most likely time estimate denoted by t_m . It is defined as the best possible time estimate that a given activity would take under normal conditions which often exist.

But he is also asked to give two other time estimates. One of these is a pessimistic time estimate. This is the best guess of the maximum time that would be required to perform an activity under the most adverse circumstances like

- (1) supply of materials not in time
- (2) non-cooperation from the workers
- (3) the transportation arrangements not being effective etc.

Thus the pessimistic time estimate is the longest time the activity would require and is denoted by t_p . On the other hand if everything goes on exceptionally well or under the best possible conditions, the time taken to complete an activity may be less than the most likely time estimate. This time estimate is the smallest time estimate known as the optimistic time estimate and denoted by t_o .

Thus, given the three time estimates for an activity, we have to find the expected duration of an activity or expected time of an activity as a weighted average of the three time estimates. PERT makes the assumption that the optimistic and pessimistic activity (t_o and t_p) are occur. It also assumes that the most probable activity time t_m , is four times more likely to occur than either of the other two. This is based on the properties of Beta distribution. Beta distribution was chosen as a reasonable approximation of the distribution of activity times. The Beta distribution is unimodal, has finite non-negative end points and is not necessarily symmetrical-all of which seen desirable properties for the distribution of activity times. The choice of Beta distribution was not based on empirical data. Since most activities in a development project occur just once, frequency distribution of such activity times cannot be developed from past data.

So, if we follow Beta distribution with weights of 1, 4, 1 for optimistic, mostly likely and pessimistic time estimates respectively a formula for the expected time denoted by t_e can be written as

$$t_e = \frac{t_o + 4t_m + t_p}{6}$$

For example if we have 2, 5 and 14 hours as the optimistic (t_o), most likely (t_m) and pessimistic (t_p) time estimate then the expected time for the activity would be

$$\begin{aligned} t_e &= \frac{2+4(5)+14}{6} \\ &= \frac{36}{6} = 6 \text{ hrs} \end{aligned}$$

If the time required by an activity is highly variable (i.e) if the range of our time estimates is very large, then we are less confident of the average value. We calculate them if the range were narrower. Therefore it is necessary to have a means to measure the variability of the duration of an activity. One measure of variability of possible activity times is given by the standard deviation of their probability distribution.

PERT simplifies the calculation of standard deviation denoted by S_i as estimated by the formula,

$$S_t = \frac{t_p - t_o}{6}$$

S_t is one sixth of the difference between the two extreme time estimates, namely pessimistic and optimistic time estimates. The variance V_t of expected time is calculated as the square of the deviation.

(i.e.)
$$V_t = \left(\frac{t_p - t_o}{6} \right)^2$$

In the example above

$$S_t = \frac{14-2}{6} = 2 \text{ hrs}$$

$$V_t = \frac{(14-2)^2}{6^2} = 4 \text{ hr}^2$$

2.4.1 Expected length of a critical path:

The expected length of a sequence of independent activities is simply the sum of their separate expected lengths. This gives us the expected length of the entire project. We have to calculate the expected length t_e of every activity with the weights attached to the three time estimates and find the critical path in the manner described previously. The expected length of the entire project denoted by T_e is the length of the critical path (i.e.) the sum of the t_e 's of all activities along the critical path.

In the same way, the variance of a sum of independent activity times is equal to the sum of their individual variances. Since T_e is the sum of t_e 's along the critical path, then variance of T_e equals the sum of all the variances of the critical activities. The standard deviation of the expected project duration is the square root of the variance T_e as calculated above.

At this juncture, consider the following example to illustrate the application of these formulae.

Example

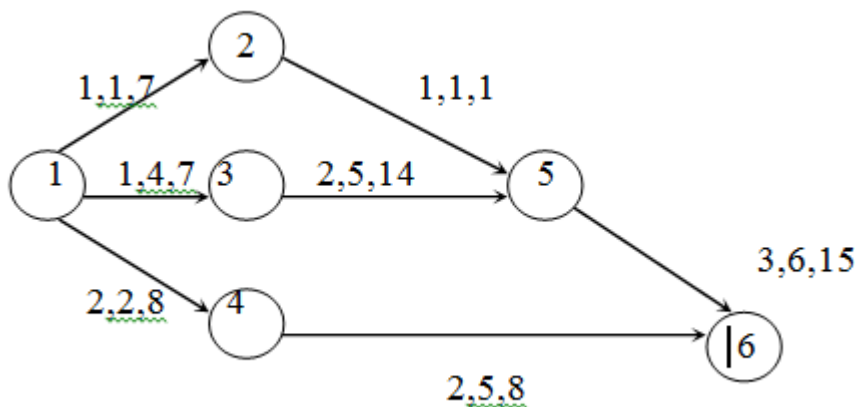

Fig. 20

Activity	Expected time (te)	Std. deviation	Variance
1-2	$(1+4+7)/6 = 2$	$(7-1)/6 = 1$	1
1-3	$(1+16+7)/6 = 4$	$(7-1)/6 = 1$	1

1-4	$(2+8+8)/6 = 3$	$(8-2)/6 = 1$	1
2-5	$(1+4+1)/6 = 1$	$(1-1)/6 = 0$	0
3-5	$(2+20+14)/6 = 6$	$(14-2)/6 = 2$	4
4-6	$(2+20+8)/6 = 5$	$(8-2)/6 = 1$	1
5-6	$(3+24+15)/6 = 7$	$(15-3)/6 = 2$	4

For each activity, the optimistic, most likely and pessimistic time estimates are labeled in the same order. Using PERT formulae for t_e and S_i , tabulate the results as above.

To calculate the critical path, list all the three paths with their expected time of completion from figure 21.

- 1-2-5-6 = 10
- 1-3-5-6 = 17
- 1-4-6 = 8

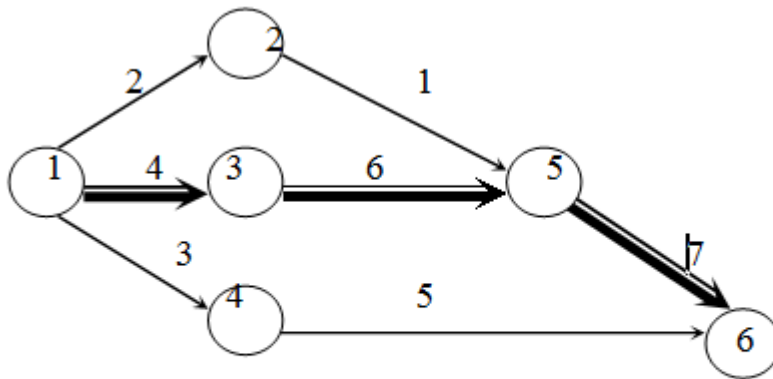

Expected time and Critical path

Fig. 21

The longest path is the critical path and it consists of activities 1-3, 3-5 and 5-6 with a length $T_e = 4 + 6 + 7 = 17$. The variance of the critical path is then $V_T = \text{Variance of 1-3} + \text{variance of 3-5} + \text{variance of 5-6}$.

$$V_T = 1 + 4 + 4 = 9$$

Standard deviation of duration of the critical path

$$\sigma = \sqrt{V_T} = \sqrt{9} = 3$$

So far what we have done with PERT model is to recognize uncertainty by using three time estimates and these are reduced to a single time estimate for finding the critical path. It can be used to find early start-early finish programme, late start-late finish programme and slack. The variability of the time estimates for each activity is also reduced to a standard deviation and variance and this is used to find the standard deviation of expected completion time for the project.

2.4.2 Probability of completing a project with a given date

One may wonder how the calculations made to find T_e , S_T and V_T are useful to a project manager. These parameters serve as a very useful tool for a project manager to estimate the probability of completing a project with a given date.

We have seen that the time required for an activity is uncertain and hence it is a random variable. Its average or expected value (t_e) can be estimated on the basis of an assumption regarding the type of probability distribution, and three points on this distribution namely optimistic, most likely and pessimistic time estimates.

We estimate the average, or expected, projected length, T_e by adding the expected activity durations along the critical path. As the t_e 's are all random variables, then so is T_e . It is assumed that T_e is to follow approximately a normal distribution. This gives the probability of completing a project with a given date.

Referring to the example illustrated above, the expected project length is 17 days and a standard deviation of 3 days. These are the two parameters useful to calculate the probability if the due date is to be met. For example, if the due date is T and this is deviated from the mean by $T - T_e$ and the same can be expressed as the ratio of standard deviation as $(T - T_e)/S.D.$ This is defined as the standard normal variates denoted by Z .

It is known that in a normal distribution the area under the normal curve gives the probability. For $Z = 0$, $T = T_e$ and hence if the due date is exactly the expected project length, the probability of completing the project is 50% as represented by the area to the left of the central line.

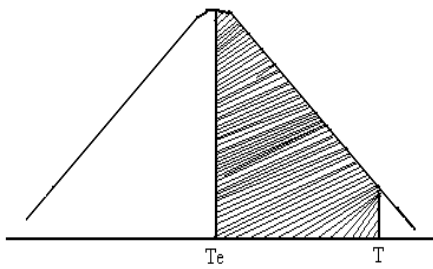

$$z = 0 \quad z = \left[\frac{T - T_e}{\sigma} \right]$$

Fig. 22

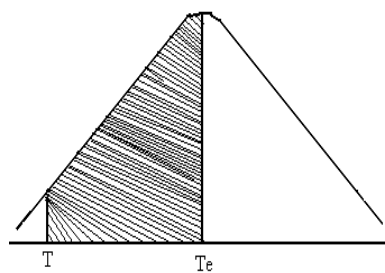

$$z = \left[\frac{T - T_e}{\sigma} \right]$$

Fig 23

If in this example the due date is 20 days, $Z = (20 - 17)/3 = 1$. For the value of $Z = 1$ the area between $Z = 0$ and $Z = 1$ is estimated (or as found from the statistical tables) as 0.3413. This is indicated in figure 222 by the shaded portion. Hence the probability of completing the project in 20 days will be $0.50 + 0.3413 = 0.8413$ or 84.13%. Similarly if the due date is 14 days, the corresponding value of $Z = -1$. For this value of $Z = -1$ also, area is 0.3413 but to the left of the mean as indicated in figure 23.

The probability of completing the project in 14 days will be $=0.5000 - 0.3413 = 0.1587$ or 15.87%.

Example The following table lists the jobs of a network with their time estimates.

Job i-j	Duration (days)		
	Optimistic	Most likely	Pessimistic
1 2	3	6	15
1 6	2	5	14
2 3	6	12	30
2 4	2	5	8
3 5	5	11	17
4 5	3	6	15
6 7	3	9	27
5 8	1	4	7
7 8	4	19	28

- (a) Draw the project network.
 - (b) Calculate the length and variance of the critical path.
 - (c) What is the approximate probability that the jobs on the critical path will be completed by the due date of 42 days?
 - (d) What due date has about 90% chance of being met?
- Solution:

Before proceeding to draw the project network, let us calculate the expected time of activity t_e , standard deviation and variance of the expected time of activity using

$$t_e = \frac{(t_o + 4t_m + t_p)}{6}$$

$$S.D = (t_p - t_o) / 6; \quad \text{Variance} = (S.D)^2$$

Activity	t_e (Days)	S.D (Days)	Variance
1 - 2	7	2	4
1 - 6	6	2	4
2 - 3	14	4	16
2 - 4	5	1	1
3 - 5	11	2	4
4 - 5	7	2	4
6 - 7	11	4	16
5 - 8	4	1	1
7 - 8	18	4	16

(a) Project Network:

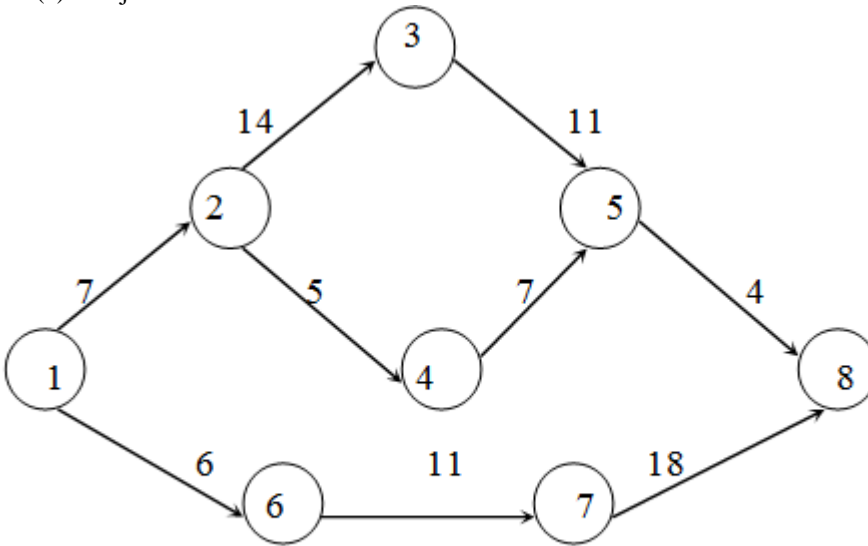

Expected time and Critical path

Fig. 24

Expected time and Critical path

Fig. 24

- (b) There are three paths:

$$1-2-3-5-8 = 36 \text{ days}$$

$$1-2-4-5-8 = 23 \text{ days}$$

$$1-6-7-8 = 35 \text{ days}$$

1-2-3-5-8 is the longest path and hence the critical path.

Expected length of the critical path is 36 days. The variance for 1-2, 2-3, 3-5 and 5-8 are 4, 16, 4 and 1 respectively and variance of the projection duration is 25 and hence

Standard deviation of the project duration = $\sqrt{25} = 5$ days.

- (c) Due date = 42 days (T)
Expected duration = 36 days (T_e) and S.D = 5 days (o)

$$Z = (T - T_e) / S.D. = (42 - 36) / 5 = 1.2$$

The area under the normal curve for $Z = 1.2$ is 0.3849.
Therefore, the probability of completing the project in 42 days

$$\begin{aligned} &= 0.5000 + 0.3849 \\ &= 0.8849 \\ &= 88.49\% \end{aligned}$$

2.4.3 Exercise

- (1) A project has the following characteristics:

Activity	Optimistic time	Pessimistic time	Most likely time
1-2	1	5	1.5
2-3	1	3	2
2-4	1	5	3
3-5	3	5	4
4-5	2	4	3
4-6	3	7	5
5-7	4	6	5
6-7	6	8	7
7-8	2	6	4
7-9	5	8	6
8-10	1	3	2
9-10	3	7	5

Construct a network. Find the critical path and variance for each event. Find the project duration at 95% probability.

2.5 Resource Scheduling in Network

In scheduling projects using PERT or CPM, we have assumed that the only constraint for an activity is to fix the starting date and the finishing date. An activity may be started as soon as all its predecessors have been completed. Thus we have an early start schedule for all the activities. In such scheduling procedures it is assumed that the resources required to perform activities are available to any unlimited extent or atleast sufficient resources are available for the activity to be started sometime between earliest and latest start dates. But we come across situations where the project managers have to face the problem of limited or fixed resources like manpower availabilities, machine availabilities and capital mobilization. Activities, which occur on parallel paths through network, may compete for the same resource.

Recently considerable work is in progress in developing heuristic programmes for solving large combinatorial problems. A heuristic can be defined as a guide or method of reducing search in a problem-solving situations. It gives a rule of thumb. Businessmen employ heuristics quite often for their problems. As an example we consider the classic management rule, "Handle only exceptional problems and let the subordinates decide on routine matters" as a heuristic. Sometime a simple rule of thumb may not be enough, but other rules are also to particular problem is referred to as 'heuristic programme' requiring a computer for complex problems. A number of different heuristic programmes for scheduling projects with limited resources have been developed recently. These programmes are classified in any one of the two following forms.

1. Resource leveling programmes: These programmes seek an attempt to reduce peak resource requirements and smooth out period to period assignments with a restriction on project duration. In other words, in these programmes the resource requirements (manpower or money power) are kept at a constant level by altering the start time of the different activities. But at the same time, the project duration and the sequence are not violated.
2. Resource allocation programmes: These programs make an attempt to allocate the available resources (manpower, machine hours, money) to project activities and to find the shortest project schedule consistent with fixed resource limits. The following articles deal with these types of heuristic programmes.

2.5.1 Resource leveling program

Resource leveling programmes are most appropriate to situations where we maintain a relatively stable employment levels and utilize the resources at a more constant rate. If the levels change either way the expenses are involved in hiring, training, firing, unemployment insurance and so on. The activity slack is a measure of flexibility in the assignment of activity start times. We may use activity slack as a means to smoothing peak resource requirements. The procedure involves preparing an early-start early-finish schedule for the project on time scale and then plotting a resource-loading chart for the schedule. The activities are shifted suitably to reduce the peak resource requirements without violating the sequence and preserving the finish date.

2.5.2 Resource Allocation

In many cases the scheduling problem does not involve only smoothing of requirements but also allocation of resources. Almost there are some constraints, which may be in the form of limited men, machines or finance. The various activities have to work at their optimum taking into considerations these restrictions.

The resource-leveling model could be modified to give us the desired results. The constraint of the fixed due date would have to be removed and concentrate on pushing down the trigger levels until peak requirements are all under resource limits. If the limits are confining, the jobs will be pushed to the right, thereby delaying the project due date on the schedule graph. The constraints cannot be based both on project due date and resource limits.

Resources are allocated on a period-by-period basis to accommodate some available job, after their predecessors have been completed. The essential elements are determining which jobs are to be scheduled and which are to be postponed. The slack is usually the basis on which priority is accorded to various job. Hence, the jobs, which are most critical, will be scheduled first.

In any problem on resource allocation, the following three rules may be applied.

- (i) The resources are to be allocated in the order of time i.e. start on the first day and schedule all possible jobs then the second day etc.
- (ii) When several jobs compete for the same resources preference should be given to the job with least slack.
- (iii) The non-critical jobs should be rescheduled so that resources would be free for scheduling the critical jobs.

2.5.3 Exercises

1. Following are the manpower requirements for each activity in a project.

Activity	Normal Time (days)	Manpower required per day
1 - 2	10	2
1 - 3	11	3

2 - 4	13	4
2 - 6	14	3
3 - 4	10	1
4 - 5	7	3
4 - 6	17	5
5 - 7	13	3
6 - 7	9	8
7 - 8	1	11

- (i) Draw the network and find 'total float' and 'free float' for each activity.
- (ii) The contractor stipulates that during the first 26 days only 4 to 5 men and during the remaining days 8 to 11 men only can be made available. Rearrange the activities for leveling the manpower resources satisfying the above condition.
2. For a project consisting of several activities, the duration and required resources for carrying out each of the activities and their availabilities are given below. Find the project completion time under the given resource constraints.

Activity	Resources Required		Duration (days)
	Equipment	Operators	
1 - 2	X	30	4
1 - 3	Y	20	3
1 - 4	Z	20	6
2 - 4	X	30	4
2 - 5	Z	20	8
3 - 4	Y	20	4
3 - 5	Y	20	4
4 - 5	X	30	6

Resource availability: Number of operators = 50

Equipments X = 1, Y = 1, Z = 1

3 Inventory Control

3.1 Introduction

Inventory is the physical stock of items held in any business for the purpose of future production or sales. In a production shop the inventory may be in the form of raw materials. When the items are in production process, we have the inventory as in-process inventory and at the end of the production cycle inventory is in the form of finished goods. We shall be dealing only with the finished goods inventory. The problem of determining inventory policies is not a new concept beginning. It is only in the last two decades that it has been tackled with quantitative techniques and mathematical models, a method amenable to optimization.

Inventory planning is the determination of the type and quantity of inventory items that would be required at future points for maintaining production schedules. Inventory planning is generally based on information from the past and also on factors that would arise in future. Once this sort of planning is over, the control process starts, which means that actual and planned inventory positions are compared and necessary action taken so that the business process can function efficiently.

In inventory control, we are primarily concerned with the inventory cost control. The aim is focussed to bring down the total inventory cost per annum as much as possible. Two important questions are (1) how much to stock or how much to buy and (2) how often to buy or when to buy. An answer to the above questions is usually given by certain mathematical models, popularly known as 'economic order quantity models' or 'economic lot/batch size models (E.O.Q.).'

3.2 Inventory Costs

There are four major elements of inventory costs that should be taken for analysis, such as

- (1) Item cost, Rs. C_1 /item.
- (2) Ordering cost, Rs. C_2 /order.
- (3) Holding cost Rs. C_3 /item/unit time.
- (4) Shortage cost Rs. C_4 /item/Unit time.

3.2.1 Item Cost (C_1)

This is the cost of the item whether it is manufactured or purchased. If it is manufactured, it includes such items as direct material and labour, indirect materials and labour and overhead expenses. When the item is purchased, the item cost is the purchase price of 1 unit. Let it be denoted by Rs. C_1 per item.

3.2.2 Purchasing or Setup or Acquisition or Ordering Cost (C_2)

Administrative and clerical costs are involved in processing a purchase order, expediting, follow up etc., It includes transportation costs also. When a unit is manufactured, the unit set up cost includes the cost of labour and materials used in the set up and set up testing and training costs. This is denoted by Rs. C_2 per set up or per order.

3.2.3 Inventory holding cost (C_3)

If the item is held in stock, the cost involved is the item carrying or holding cost. Some of the costs included in the unit holding cost are

- (1) Taxes on inventories,
- (2) Insurance costs for inflammable and explosive items,

- (3) Obsolescence,
- (4) Deterioration of quality, theft, spillage and damage to times,
- (5) Cost of maintaining inventory records.

This cost is denoted by Rs. C_3 /item/unit time. The unit of time may be days, months, weeks or years.

3.2.4 Shortage Cost (C_4)

The shortage cost is due to the delay in satisfying demand (due to wrong planning); but the demand is eventually satisfied after a period of time. Shortage cost is not considered as the opportunity cost or cost of lost sales. The unit shortage cost includes such items as,

- (1) Overtime requirements due to shortage,
- (2) Clerical and administrative expenses.
- (3) Cost of expediting.
- (4) Loss of goodwill of customers due to delay.
- (5) Special handling or packaging costs.
- (6) Lost production time.

This cost is denoted by Rs. C_4 per item per unit time of shortage.

3.3 Inventory Models(E.O.Q. Models)

The inventory control model can be broadly classified into two categories:

- (1) Deterministic inventory problems.
- (2) Probabilistic or stochastic inventory problems.

In the deterministic type of inventory control, the parameters like demand, ordering quantity cost, etc are already known or have been ascertained and there is no uncertainty. In the stochastic inventory control, the uncertain aspects are taken into account.

First let us consider the inventory control of the deterministic type. There are four EOQ models which are discussed below. The first one is the well-known Wilson's inventory model.

3.3.1 Model-1 Purchasing model with no shortages(Wilson's model)

The following assumptions are made in deriving the formula for economic order quantity.

- (1) Demand (D) is at a constant rate.
- (2) Replacement of items is instantaneous (lead time is zero).
- (3) The cost coefficients C_1 , C_2 , and C_3 are constant.
- (4) There is no shortage cost or $C_4 = 0$.

This mode represented graphically in fig. 1. This is also known as a saw tooth model (because of its shape).

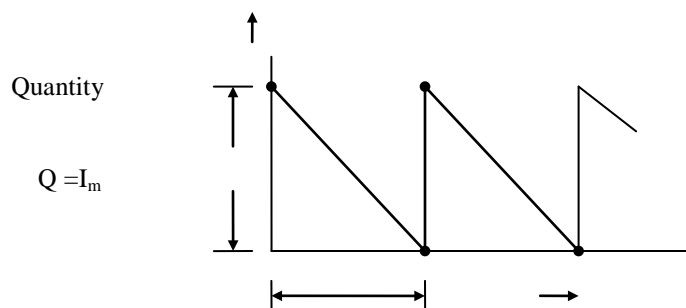

t
Time

Fig. 1

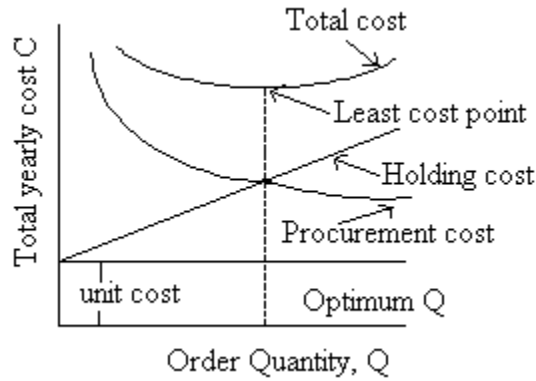

Fig. 2

In this model, at time $t = 0$, we order a quantity Q which is stored as maximum inventory, I_m . The time ' t ' denotes the time of one period or it is the time between orders or it is the cycle time. During this time, the items are depleting and reaching a zero value at the end of time t . At time t another order of the same quantity is to be placed to bring the stock up to Q again and the cycle is repeated. Hence this is a fixed order quantity model.

The total cost for this model for one cycle is made up of three cost components.

Total cost/period = (Item cost + set up cost + holding cost/period)

Item cost per period = (Cost of item) \times (number of items ordered/period)

$$= C_1 Q \tag{1}$$

Purchase or set up cost per period = C_2 (only one set up per period)

Item holding cost per period = (Holding cost) \times (average inventory per period) \times (time per period)

$$= C_3 \frac{Q}{2} \times t \tag{2}$$

$$\text{Therefore the total cost per period } (C') = C_1 Q + C_2 + C_3 \frac{Q}{2} \times t \tag{3}$$

$$\text{But the time for one period } t = Q/D \tag{4}$$

$$\text{Therefore the total cost per unit time, } C = C'/t \tag{5}$$

$$C + C_1 D + C_2 \frac{D}{Q} + C_3 \frac{Q}{2} \tag{6}$$

$$\text{Substituting the value of } t, \text{ we get } C = C_1 D + C_2 \frac{D}{Q} + C_3 \frac{Q}{2} \tag{7}$$

The cost components of the above equations can be represented as shown in fig 2 and an optimum order quantity for one period is found when

Purchase cost = Item holding cost.

$$\frac{C_2 D}{Q} = \frac{C_3 Q}{2}$$

$$Q_2 = \frac{2C_2 D}{C_3} \quad Q^* = \sqrt{\frac{2C_2 D}{C_3}} \quad (8)$$

This minimum inventory cost per unit time can also be found by differentiating C with respect to Q and equating it to zero. The derivative of the equation is,

$$\frac{dC}{dQ} = \frac{-C_2 D}{Q^2} + \frac{C_3}{2} = 0 \quad (9)$$

Solving for Q , we get

$$Q^* = \sqrt{\frac{2C_2 D}{C_3}} \quad (10)$$

This value of Q^* is the economic order quantity and any other order quantity will result in a higher cost.

The corresponding period t^* is found from

$$t^* = Q^*/D \quad (11)$$

The optimum number of orders per year is determined from

$$N^* = D/Q^*$$

where D is the demand per year.

Example 1: The demand rate for a particular item is 12000 units/year. The ordering cost is Rs. 100 per order and the holding cost is Rs. 0.80 per item per month. If no shortages are allowed and the replacement is instantaneous, determine:

- (1) The economic order quantity.
- (2) The time between orders.
- (3) The number of orders per year.
- (4) The optimum annual cost if the cost of item is Rs. 2 per item.

Solution: Note that the holding cost is given per month and convert the same into cost per year.

$$\begin{aligned} C_1 &= \text{Rs. 2/item} \\ C_2 &= \text{Rs. 100/order} \\ C_3 &= \text{Rs. 0.80/item/month} \\ &= \text{Rs. 9.6/item/year} \\ D &= 12000 \text{ items/year} \end{aligned}$$

- a) The economic order quantity

$$\begin{aligned}
 Q^* &= \sqrt{\frac{2C_2D}{C_3}} \\
 &= \sqrt{\frac{2 \times 100 \times 12000}{9.6}} \\
 &= 500 \text{ units}
 \end{aligned}$$

b) The time between orders

$$\begin{aligned}
 t^* &= Q^*/D = 500/12000 \text{ yr.} \\
 &= 500/1000 \text{ month} \\
 &= 0.5 \text{ month}
 \end{aligned}$$

c) The number of orders/year

$$N = D/Q^* = 12000 / 500 = 24$$

d) The optimum annual cost

$$\begin{aligned}
 &= (\text{Number of orders}) \times [\text{Cost of one cycle}] \\
 &= (\text{Number of orders}) \times [\text{Item Cost} + \text{Order Cost} + \text{Holding Cost}] \\
 &= (24) \times [(500 \times 2) + 100 + (500 / 2 \times 0.5 \times 0.80)] \\
 &= Rs.28800
 \end{aligned}$$

3.3.2 Model-2 (Purchasing model with shortages)

In this model, shortages are allowed and consequently a shortage cost is incurred. Let the shortages be denoted by 'S' for every cycle and shortage cost by C_4 per item per unit time. This model is illustrated in Fig .3

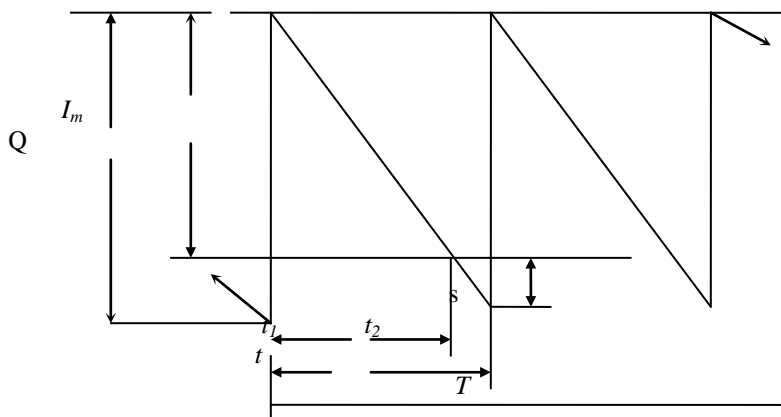

Fig. 3

Fig. 3 shows that the back ordering is possible (i.e.) once an order is received, any shortages can be made up as the items are received. Consequently shortage costs are due to being short of stock for a period of time.

The cost per period includes four cost components.

Total cost per period = Item cost + Order cost + Holding cost + Shortage cost

Item cost per period = (item cost) × (number of items/period)

$$= C_1 Q \quad (13)$$

Order cost per period = C_2

Let t_1 be the time period during which only the items are held in stock. Let the maximum inventory be denoted by I_m and this is equal to $(Q - S)$ or $I_m = (Q - S)$

From similar triangle concept, the following equations can be obtained, referring to fig 3

$$t_1 / I_m = t / Q \quad (16)$$

or
$$t_1 = t I_m / Q = t(Q - S) / Q \quad (17)$$

$$t_2 / S = t / Q \quad \text{or} \quad t_2 = t S / Q \quad (18)$$

Since time of one period $t = Q / D$

$$t_1 = \frac{Q - S}{Q} \frac{Q}{D} \quad (19)$$

$$t_2 = \frac{S}{Q} \frac{Q}{D} \quad (20)$$

Holding cost per period

= Average stock/period × t_1 × holding cost/unit/unit time

$$= I_m / 2 \times t_1 \times C_3$$

$$= C_3 \times (Q - S) / 2 \times (Q - S) / Q \times Q / D$$

$$= \frac{C_3 (Q - S)^2}{2D} \quad (21)$$

Shortage cost per period

Average shortages/period × t_2 × shortage cost

$$\begin{aligned}
&= s/2 \times s/Q \times Q/D \times C_4 \\
&= C_4 \times s^2/2D \quad (22)
\end{aligned}$$

Adding all the four cost components, we get the inventory cost per period.

$$C' = C_1Q + C_2 + \frac{C_3(Q-S)^2}{2D} + \frac{C_4S^2}{2D} \quad (23)$$

Therefore inventory cost per unit of time is obtained by dividing C' by t or Q/D

Therefore,

$$\begin{aligned}
C &= \frac{C_1QD}{Q} + \frac{C_2D}{Q} + \frac{C_3(Q-S)^2D}{2D \times Q} + \frac{C_4S^2D}{2D} \frac{D}{Q} \\
&= C_1D + \frac{C_2D}{Q} + \frac{C_3(Q-S)^2}{2Q} + \frac{C_4S^2}{2Q} \quad (24)
\end{aligned}$$

This is an expression involving two variables Q and S . For optimum values of Q^* and S^* , the function has to be differentiated partially with respect to Q and S and equated to zero.

$$\begin{aligned}
\frac{\partial C}{\partial Q} &= 0 \\
&= \frac{-C_2D}{Q^2} + \frac{C_3}{2} - \frac{C_3S^2}{2Q^2} - \frac{C_4S^2}{2Q^2} \\
&= -\frac{C_2D}{Q} + \frac{C_3}{2} - \frac{S^2}{2Q^2}(C_3 + C_4) \quad (25)
\end{aligned}$$

$$\begin{aligned}
\frac{\partial C}{\partial S} &= 0 \\
&= -C_3 + \frac{C_3S}{Q} + \frac{C_4S}{Q} = -C_3 + \frac{S(C_3+C_4)}{Q} \quad (26)
\end{aligned}$$

Solving the equation (26) for S , we get

$$S = \frac{C_3Q}{C_3+C_4} \quad (27)$$

Substituting the equation (27) into the equation (25), we get

$$0 = \frac{-C_2D}{Q^2} + \frac{C_3}{2} - \frac{C_3+C_4}{2Q^2} \times \frac{(C_3+Q)^2}{(C_3+C_4)} \quad (28)$$

$$= \frac{-C_2D}{Q^2} + \frac{C_3}{2} - \frac{C_3^2}{2(C_3+C_4)} \quad (29)$$

Solving equation (29) for Q , we get

$$Q^* = \sqrt{\frac{2C_2D}{C_3}} \sqrt{\frac{C_3+C_4}{C_4}} \quad (30)$$

which is the economic or optimum order quantity.

$$S^* = \sqrt{\frac{2C_2D}{C_4}} \sqrt{\frac{C_3}{C_3+C_4}} \quad (31)$$

Example: The demand for an item is 18000 units/year. The cost of one purchase is Rs. 400. The holding cost is Rs. 1.2 per unit per year. The item cost is Rs. 1 per item. The shortage cost is Rs. 5 per unit per year. Determine:

- The optimum order quantity.
- The time between orders.
- The number of orders per year.
- The optimum shortages.
- The maximum inventory.
- The time of items being held.
- The optimum annual cost.

Solution

$$D = 18000 \text{ units/year} \quad \text{or} \quad 1500 \text{ units/month}$$

$$C_1 = \text{Rs. } 1/\text{item} \quad C_3 = \text{Rs. } 1.2/\text{year/item}$$

$$C_2 = \text{Rs. } 400/\text{order} \quad C_4 = \text{Rs. } 5/\text{year/item}$$

$$\text{a) } Q^* = \sqrt{\frac{2C_2 D}{C_3}} \sqrt{\frac{C_3 + C_4}{C_4}} = \sqrt{\frac{2 \times 400 \times 18000}{1.2}} \times \sqrt{\frac{6.2}{5}}$$

$$= 3857 \text{ Units.}$$

$$\text{b) } t^* + Q^*/D = 3857/1500 = 2.57 \text{ months}$$

$$\text{c) } \text{Number of orders per year} = 12/2.57 = 4.66$$

$$\text{d) } S^* = \sqrt{2C_2 D/C_4} \sqrt{C_3/(C_3+C_4)} = 747 \text{ items}$$

$$\text{e) } I_{\max} = Q^* - S^* = 3857 - 747 = 3110 \text{ items}$$

$$\text{f) } t_1 = I_{\max}/D = 3110/1500 = 2.07 \text{ months}$$

$$\text{g) } \begin{aligned} &\text{Annual cost} = \text{Item cost} \\ &+ \text{Ordering cost} \\ &+ \text{Holding cost} \\ &+ \text{Shortage cost} \end{aligned}$$

Item cost = Rs. 3857 per order

Order cost = Rs. 400 per order

$$\text{Holding cost} = \frac{\text{Rs. } 1.2 \times 3110 \times 2.07}{2 \times 12}$$

$$= \text{Rs. } 322.14 \text{ per order}$$

$$\text{Shortage cost} = \frac{\text{Rs. } 5 \times 747 \times 0.5}{2 \times 12}$$

$$= \text{Rs. } 77.75 \text{ per order}$$

$$\begin{aligned}
 \text{Total cost per order} & \\
 &= 3857 + 400 + 77.75 + 322.14 \\
 &= \text{Rs. } 4656.89
 \end{aligned}$$

$$\begin{aligned}
 \text{Annual cost} &= \text{Number of orders/year} \times \text{cost} \\
 &= 4.66 \times 4656.89 \\
 &= \text{Rs. } 21701.
 \end{aligned}$$

3.3.3 Model-3(Manufacturing model with no shortages)

In this model the following assumptions are made:

- (1) Demand is at a constant rate (D).
- (2) All cost coefficients (C_1, C_2, C_3) are constants.
- (3) There is no shortage cost, or $C_4 = 0$.
- (4) The replacement rate is finite and greater than the demand rate. This is also called replenishment rate or manufacturing rate, denoted by R .

Schematically, this model is illustrated in fig 4

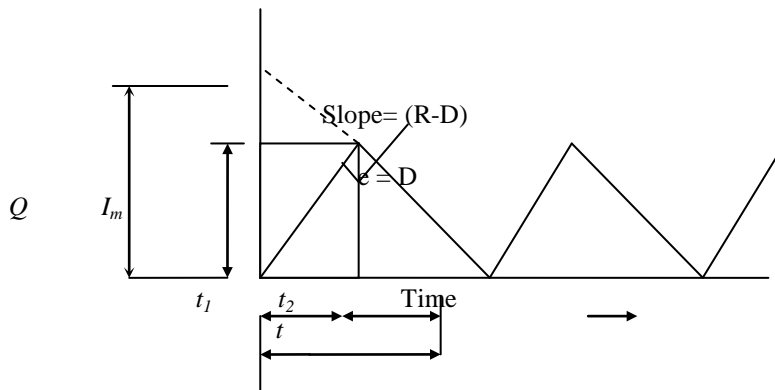

Fig. 4

The total cost of inventory per period is the sum of three components: item cost, order cost and items holding cost.

Let I_m be the maximum inventory, t_1 be the time of manufacture and t_2 be the time during which there is no supply.

In this model, all items required for a cycle are not stored at the beginning as in Wilson's Model. The items are manufactured at a higher rate than the demand so that the difference $(R-D)$ is the existing inventory till the items are exhausted.

$$\text{Item cost/period} = C_1 Q \quad (32)$$

$$\text{Order cost/period} = C_2 \quad (33)$$

$$\text{Item holding cost/period} = C_3 \times I_m \times (t_1 + t_2) / 2 \quad (34)$$

$$= C_3 I_m \times t / 2 \quad (35)$$

$$I_m = t_1 (R - D) \quad (36)$$

But $t_1 = Q/R$ (37)

Therefore $I_m = (Q/R)(R - D)$ (38)

Substituting the value of I_m , we get the total cost of inventory per period.

$$C' = C_1 Q + C_2 + C_3 (Q/R)(R - D) \times t/2 \quad (39)$$

Total cost of inventory per unit time

$$C = C'/t \quad (40)$$

$$= C_1 Q/t + C_2/t + C_3 (Q/R)(R - D) \times t/2 \quad (41)$$

But $t = Q/D$

Substituting the value of t we get

$$C = C_1 D + C_2 D/Q + C_3 (Q/R)(R - D)/2 \quad (42)$$

Differentiating C with respect to Q and setting equal to zero for minimum C , we get,

$$\frac{dC}{dQ} = 0 - \frac{C_2 D}{Q^2} + \frac{C_3 (R - D)}{2R} = 0 \quad (43)$$

Solving equation (43), we get

$$Q^* = \sqrt{\frac{2C_2 D}{C_3}} \sqrt{\frac{R}{R - D}} \quad (44)$$

This gives the economic order quantity and is a balance between holding and set up costs.

Example: The demand for an item in a company is 18000 units/year and the company can produce at the rate of 3000 per month. The cost of one set up is Rs. 500 and the holding cost of 1 unit per month is 15 paisas. Determine:

- The optimum manufacturing quantity.
- The maximum inventory.
- The time between orders.
- The number of orders/year.
- The time of manufacture.
- The optimum annual cost if the cost of the item per unit is Rs. 2.

Assume no shortages.

Solution

$$C_1 = \text{Rs. 2 per item.}$$

$$C_2 = \text{Rs. 500 per order.}$$

$$C_3 = \text{Rs. 0.15 per item per month}$$

$$D = 18000/\text{year} = 1500/\text{month}$$

$$R = 3000/\text{month}$$

- a) Optimum manufacture quantity

$$Q^* = \sqrt{\frac{2C_2D}{C_3}} \sqrt{\frac{R}{R-D}}$$

$$= \sqrt{\frac{2 \times 500 \times 1500 \times 3000}{0.15(3000-1500)}} = 4470 \text{ units}$$

- b) The maximum inventory

$$I_m = Q(R-D)/R = 4470 \times 1500/3000 = 2235 \text{ units}$$

- c) The time between orders

$$t = Q/D = 4470/1500 = 2.98 \text{ months} \\ \approx 3 \text{ months}$$

- d) The number of orders/year

$$N = 12/3 = 4$$

- e) The time of manufacture

$$t_1 = Q/R = 4470/3000 = 1.490 \text{ months}$$

- f) The optimum annual cost

$$= \text{Item cost} + \text{Ordering cost} + \text{Holding cost}$$

$$\text{Item cost} = 18000 \times 2 = \text{Rs. 36000}$$

$$\text{Ordering cost} = 500 \times 18000/4470 = \text{Rs. 2013.5}$$

$$\begin{aligned}\text{holding cost} &= 0.15 \times 12 \times 2235 \times 18000 / 36000 \\ &= \text{Rs. } 2011.5\end{aligned}$$

$$\begin{aligned}\text{Total annual cost} &= 36000 + 2013.5 + 2011.5 \\ &= \text{Rs. } 40025.0\end{aligned}$$

3.3.4 Model-4 (Manufacturing model with shortages)

The assumptions in this model are the same as in model 3 except that the shortages are also considered. This model is illustrated in the figure in power point presentation of the lecture, given on the next page.

There are four components of inventory costs in this model. They are

- (1) Item cost.
- (2) Set up or order cost.
- (3) Items holding cost.
- (4) Shortage cost.

The items t_1 , t_2 , t_3 and t_4 are as represented in figure on the next page. The total cost per period t is

$$C' = C_1 Q + C_2 + C_3(t_1 + t_2)I_m/2 + C_4(t_3 + t_4)S/2 \quad (46)$$

The values of t_1 , t_2 , t_3 and t_4 are to be determined in terms of Q and S , so that the cost is expressed as a function of only two variable Q and S .

Final results are given below without proof.

$$\text{So } Q^* = \sqrt{\frac{2C_2D}{C_3(1-D/R)}} \sqrt{\frac{C_3+C_4}{C_4}} \quad (47)$$

and

$$S^* = \sqrt{\frac{2C_2D}{C_4}} \sqrt{1-D/R} \sqrt{\frac{C_3}{C_3+C_4}}$$

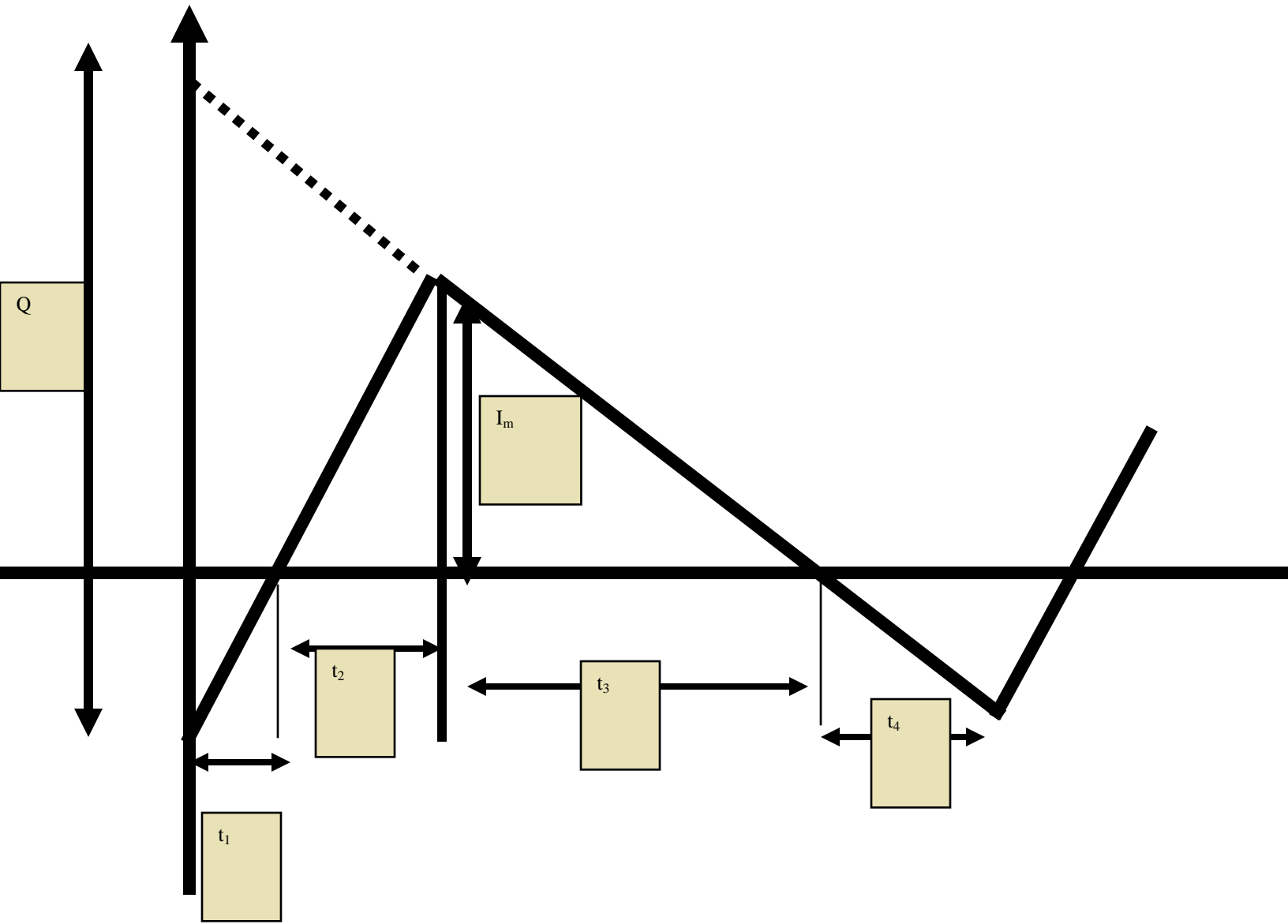

3.4 Order Quantity with Price Break

The concept of Economic Order Quantity fails in certain cases where there is a discount offered when purchases are made in large quantities. Certain manufacturers offer reduced rate for items when a larger quantity is ordered. It may appear that the inventory holding cost may increase if large quantities of items are ordered. But if the discount offered is so attractive that it even outweighs the holding cost, the probably the order at levels other than the EOQ would be economical. An illustration is given in the following example and the rationale is explained.

Example: A company uses 12000 items per year supplied ordinarily at a price of Rs. 3.00 per item. Carrying costs are 16% of the value of the average inventory and the ordering costs are Rs. 20 per order. The supplier however offers discounts as per the table below:

Order size	Price per item
Less than 2000	Rs. 3.00
2000 to 3999	Rs. 2.90
4000 or more	Rs. 2.85

Compute the economic order size.

$$EOQ = \sqrt{\frac{2 \times 12000 \times 20}{3.00 \times 0.16}} = 1000$$

EOQ at Rs. 2.90 per item

$$= \sqrt{\frac{2 \times 12000 \times 20}{2.90 \times 0.16}} = 1017$$

EOQ at Rs. 2.85 per item

$$= \sqrt{\frac{2 \times 12000 \times 20}{2.85 \times 0.16}} = 1026$$

The EOQ at Rs. 2.90 per item = 1017. But the price per item is Rs. 2.9 only if the items are ordered in the range of 2000 to 3999. This is therefore an infeasible solution. Similarly the EOQ at Rs. 2.85 per item is 1026. This price is valid only for items ordered in the range 4000 or more. This is also an infeasible solution.

We follow the routine procedure and calculate the cost for various order sizes: 1000, 2000, 4000,

Order size

	1000	2000	4000
Item cost (Rs.)	36000	34800	34200
Order cost (Rs.)	240	120	60
Holding cost (Rs.)	240	464	912

3.5 Exercises

1. Assume the following price structure

Units	Units Price
-------	-------------

0-199	Rs. 10.00
200-399	9.75
400-599	9.50
600	9.25

Purchase cost per order = Rs. 25
 Cost of the item = Rs. 10
 Annual demand = 950 Units
 Carrying cost = Rs. 2/Unit/year

2. Find the optimal order quantity for a product for which the price-breaks are as follows:

Items q	Price/Unit
$0 \leq q < 100$	Rs. 20
$100 \leq q < 200$	Rs. 18
$200 \leq q$	Rs. 16

The monthly demand for the product is 600 units. The storage cost is 15% of unit cost and the cost of ordering is Rs. 30 per order.

3.6 Dynamic Order Quantity

The basic assumption in the derivation of Economic Order Quantity models discussed previously is that the demand is uniform. But in certain situations the demand is not uniform. It may rise and fall, depending on seasonal influences. A general method is discussed below that can be applied to any pattern of varying demand due to seasonal or irregular variations.

Consider the following example to illustrate how a varying demand problem can be tackled. This is known as Dynamic Order Quantity model.

Example: The requirements for 12 months are given below:

Month	1	2	3	4	5	6	7	8	9	10	11	12
Requirement	20	40	10	10	10	2	40	30	40	40	10	20

Set up cost = Rs. 20
 Unit price = Rs. 5 per item.
 Interest = 24% per year
 or 2% per month.

Solution: To calculate the dynamic order quantity we can adopt the following procedure.

The first month's requirement has to be ordered in the first month itself at a procurement cost of Rs. 20. Now we have to decide whether the second month's requirement can also be ordered along with first month's requirement. This involves additional carrying cost, but this will result in saving an extra set up. Hence if the saving on set up costs outweighs the carrying costs, then we include the second month's requirements along with the first month. Similarly a decision can be taken whether to include the third month's requirement in the first month itself. This procedure is followed until the procurement costs and carrying costs are balanced.

Let n represent the month, $n = 1, 2, \dots, 12$. Let R_n be the requirement during n th month and R_{n+1} be the requirement during $(n + 1)$ th month. If the $(n + 1)$ th month requirement namely R_{n+1} is absorbed in n th month itself, the additional procurement cost is saved.

Hence the saving in procurement cost is (C_2/n) . But the additional carrying cost is $C_3 n (R_{n+1})$. If the additional carrying cost is less than the procurement cost, then the $(n+1)$ th month requirement is to be ordered also with n th month.

Hence we have to check whether

$$n R_{n+1} C_3 < C_2/n$$

$$n^2 R_{n+1} < C_2/C_3$$

If the answer to the above inequality is yes, then, the future month's requirements are included in the first month itself. If the answer is 'no', then that requirement is to be ordered afresh and this is treated as month $n = 1$. In this example $C_2/C_3 = 20/0.01 = 200$. All the eleven information can be represented in the table as shown.

Month.	Requirement. R_n	n	$n^2 R_{n+1}$.	Is $n^2 R_{n+1} < 200$	Action.
1	20	1	40	Yes	include 40 in month 1
2	40	2	40	Yes	include 10 in month 1
3	10	3	90	Yes	include 10 in month 1
4	10	4	160	Yes	include 10 in month 1
5	10	5	50	Yes	include 2 in month 1
6	2	6	1440	No	set up again in month 7
Total	92				
7	40	1	30	Yes	include 10 in 7th month.
8	30	2	160	Yes	include 40 in 7th month.
9	40	3	360	No	set up again in month 10
Total	110				
10	40	1	10	Yes	include 10 in month 10
11	10	2	80	Yes	include 20 in month 10
12	20				
Total	70				

Hence we order three times a year in the first month, seventh month and tenth month, the batch sizes being 92, 110 and 70 respectively.

Exercise: Compute the dynamic EOQ is for the following requirements.

Month	1	2	3	4	5	6	7	8	9	10	11	12
Requirement.	50	100	10	170	150	180	1	260	100	80	150	200

3.7 ABC Analysis

The ABC analysis is the analysis that attracts management on those items where the greatest savings can be expected. This is a simple but powerful tool of statistical sampling in the area of inventory control or materials management.

In this analysis, the items are classified or categorized into three classes, A, B and C by their usage value. The usage value is defined as,

The ABC concept is based on Pareto's law that few high usage value items constitute a major part of the capital invested in inventories whereas a large number of items having low usage value constitute an insignificant part of the capital. If too much inventory is kept, the ABC analysis can be performed on a sample. After obtaining the random sample the following steps are carried out for the ABC analysis.

STEP 1: Compute the annual usage value for every item in the sample by multiplying the annual requirements by the cost per unit.

STEP 2: Arrange the items in descending order of the usage value calculated above.

STEP 3: Make a cumulative total of the number of items and the usage value.

STEP 4: Convert the cumulative total of number of items and usage values into a percentage of their grand totals.

STEP 5: Draw a graph connecting cumulative % items and cumulative % usage value. The graph is divided approximately into three segments, where the curve sharply changes its shape. This indicates the three segments A, B and C.

The class A items whose usage values are higher are to be carefully watched and are under the strict and continued scrutiny of the senior inventory control staff. These items should be issued only on indents sanctioned by the staff. The class C items on the other extreme can be placed on the shop floor and the personnel can help themselves without placing a formal requisition. The class B items fall in between A and C.

ABC concept conforms to the consideration implied in the EOQ model. 'A' items have high inventory carrying costs and should therefore be placed with EOQ concept. The 'C' items require very little capital and have therefore low inventory carrying costs. Hence, they can be purchased in bigger lots. 'B' items are usually placed under statistical stock control.

Example: Perform ABC analysis on the following sample of 10 items from an inventory.

Items	1	2	3	4	5	6	7	8	9	10
Annual Usage (Unit)	300	2700	30	1000	50	220	160	800	600	70
Unit Cost (Rs.)	10	15	10	5	4	100	5	5	15	10

Solution:

STEP 1: Calculate usage value by multiplying annual usage of each item with its unit cost and tabulate them and assign rank by giving rank to the largest usage value as in table below.

Items No.	Annual Usage	Ranking
1	3000	6
2	40500	1
3	300	9
4	5000	4
5	200	10
6	22000	2
7	800	7
8	4000	5
9	9000	3
10	700	8

STEP 2: Arrange items as per ranking and calculate cumulative usage and % cumulative value as in the table below.

Rank	Item No.	Annual usage	Cumulative	% of cumulative	Cumulative %
------	----------	--------------	------------	-----------------	--------------

			Annual usage	Annual usage	of item
1	2	40500	40500	47	10
2	6	22000	62500	73	20
3	9	9000	71500	84	30
4	4	5000	76500	91	40
5	8	4000	80500	94.2	50
6	1	3000	83500	98	60
7	7	800	84300	98.6	70
8	10	700	85000	99.4	80
9	3	300	85300	99.8	90
10	5	200	85500	100	100

If you draw the figure, you will see that the curve changes at points (say) X and Y. The items upto X is classified as class A items and between X and Y as class B and the rest as class C items.

3.8 Some Definitions

Lead-time: This is defined as the time interval between the placing of the orders and the actual receipt of goods.

Lead-time Demand: This is the lead-time multiplied by demand rate. For example, if the lead-time is 3 weeks and the demand is at the rate of 50 items per week, then the lead-time demand is $3 \times 50 = 150$ items.

The lead-time may not be constant. For one batch, a vendor may take 45 days and for the next batch 50 days and so on. Lead-time itself is therefore a stochastic variable. This complicates the problem of accumulating stock over the period encompassed by the lead-time. Lead-time may also be forecast exponentially as is done with the demand.

Safety stock or Buffer stock: Lead-time demand is the stock level, which, on the average is sufficient to satisfy the customer's orders as the stocks are being replenished. "On the average" would mean that during this period of replenishment 50% of the customer's order can be filled and the remaining 50% may either be refused or back ordered to be filled later. The reason for this is obvious. Forecast is after all a point estimate only. If the demand is greater than the forecasts, the customers would not be serviced. If the demand is less than the forecasts, overstocking would occur. When these two variables, stock level and service to the customer, are summed up over thousands of stock level and service to the customer, are becomes a major problem for an organisation to find an acceptable compromise between the two. Sometimes the management in an organisation would like to limit the disservice to the customer down to 5% or 10% at the cost of extra stocking. This extra stock in excess of the lead-time demand is called the safety stock. Safety stock may be expressed as percentages of the lead-time demand. It may be computed in different ways.

Reorder level: This is defined as the level of the inventory at which the order is placed. It has generally two components (i) Lead time Demand and (ii) Safety Stock.

Reorder level (ROL) = Lead time demand (LTD) + Safety stock (SS).

3.8.1 Computation of Safety Stock

As discussed earlier, if the demand exceeds the forecast, the result is bad service to the customer and if the demand is less than the forecast figure, this results in overstocking. Thus there is a forecast error. This error is assumed to be normally distributed, with zero mean. If the standard deviation of the forecast error is calculated, then safety stock may be set with the desired confidence level to result in not more the 5 or 10% shortages etc.

There is another measure of variation, popularly known as mean absolute deviation (MAD), which can be computed far more easily. It can be routinely smoothed every period for obtaining better estimates of the safety stock.

MAD is related to the standard deviation for a normal distribution as given by.

$$MAD = \sqrt{2/\pi} SD.$$

Therefore, $SD = \sqrt{\pi/2} MAD$

Now safety stock = Z (S.D)

$$= Z \sqrt{\pi/2} MAD$$

$$= K MAD$$

where K is called service factor $K = Z \sqrt{\pi/2}$

The safety stock is for just one period and has to be extended over the lead time. The necessary formula has been derived by extensive simulation by statisticians and is given below.

$$MADLT = (0.659 + 0.341 LT) MAD$$

Safety stock over the lead-time

$$= K(0.659 + 0.341 LT) MAD$$

$$= Z \sqrt{\pi/2} (0.659 + 0.34 LT) MAD$$

Example: A company uses annually 50000 units of raw materials at a cost Rs. 1.2 per item. Ordering cost of items is Rs. 45 per order and item carrying cost is 15% per year of the average inventory.

1. Find the economic quantity.
2. Suppose that the company follows the EOQ policy and it operates for 300 days a year, that the procurement time is 12 days and min, minimum and average inventories.

Solution:

D = Demand = 50000/year No. of days = 300/year

C_1 = Rs. 1.2 per item Lead time = 12 days

C_2 = Rs. 45 per order Safety stock = 500

C_3 = 15% of Rs. 1.2/item/year.
= Rs. 0.18 per item per year.

$$(1) \quad EOQ = \sqrt{\frac{2C_2D}{C_3}}$$

$$= \sqrt{\frac{2 \times 45 \times 50000}{0.18}}$$

$$= \sqrt{25000000}$$

$$= 5000$$

$$(2) \text{ Requirement per day} = 50000/300$$

$$\text{Lead time demand} = 12 \times 500/3 = 2000$$

$$\text{Safety stock} = 500$$

$$\text{Reorder level} = \text{Lead time demand} + \text{safety stock}$$

$$= 2000 + 500 = 2500$$

$$\text{Maximum inventory} = \text{E.O.Q} + \text{Safety stock}$$

$$= 5000 + 500 = 5500$$

$$\text{Minimum inventory} = \text{Safety stock} = 500$$

$$\text{Average inventory} = (\text{Max. Inv.} + \text{Min. Inv.})/2$$

$$= (5500 + 500)/2 = 3000$$

Example A scrutiny of past records gives the following distributions for lead time and daily demand during lead time.

Lead time distribution

Lead time (days)	3	4	5	6	7	8	9	10
Frequency	2	3	4	4	2	2	2	1

Demand distribution

Demand/day (units)	0	1	2	3	4	5	6	7
Frequency	2	4	5	5	4	2	1	2

What should be the buffer stock?

Solution:

Computation of average or mean lead time.

$$= \frac{\sum (\text{Frequency} \times \text{lead time})}{\sum \text{Frequency}}$$

$$= \frac{6+12+20+24+14+6+18+10}{20}$$

$$= 6 \text{ days}$$

Average demand

$$= \frac{\sum (\text{Frequency} \times \text{demand/day})}{\sum \text{frequency}}$$

$$= \frac{0+4+10+15+16+10+6+14}{25}$$

$$= 3$$

Average lead-time demand

$$= \text{Average lead time} \times \text{Average demand/day}$$

$$= 6 \times 3 = 18.$$

Maximum lead-time demand.

$$= \text{Max. lead time} \times \text{Max. demand/day}$$

$$= 10 \times 7 = 70$$

∴ Buffer stock = Max. lead time demand - Average lead time demand

*Example 7.7.3

For a fixed order quantity system find the EOQ, SS, ROL and average inventory for an item with the following data.

Demand = 10000 units

Cost of item = Re. 1

Order cost = Rs. 12

Holding cost = 24%

Post lead times = 13 days

Solution:

$$(1) \quad EOQ = \sqrt{\frac{2C_2D}{C_3}}$$

$$= \sqrt{\frac{2 \times 12 \times 10000}{0.24 \times 1}} = 1000 \text{ items}$$

$$(2) \quad \text{The Average lead time} = (13 + 14 + 15 + 16 + 17)/5$$

$$= 15 \text{ days (30 days time is omitted)}$$

Maximum lead time = 30 days

$$\text{Safety stock} = (30 - 15) \times 10000 / (30 \times 12) = 420$$

$$(3) \quad \text{Reorder level} = \text{Lead time demand} + \text{Safety stock}$$

$$= 417 + 420 = 837$$

$$(4) \quad \text{Average inventory} = (1420 + 420)/2$$

$$= 1840/2 = 920.$$

Example: An airline has determined that 10 spare brake cylinders will give them stock out risk of 30%, whereas 14 will reduce the risk to 15% and 16 to 10%. It takes 3 months to receive items from supplier and the airline has an average of 4 cylinders per month. At what stock level should they reorder assuming that they wish to maintain an 85% service level.

Solution:

Lead time demand = $3 \times 4 = 12$ items

Safety stock at 85% service

= 15% disservice

or 15% stock out risk

= 14 items

Reorder level = $12 + 14 = 26$ items.

Example: Data on the distribution of lead time for a motor component were collected as shown. Management would like to set safety stock levels that will limit the stock out to 10%.

Lead time (weeks)	1	2	3	4	5	6	7	8
Frequency of occurrence	10	20	70	40	30	10	10	10

How many weeks of safety stock are required to provide the desired service level?

Solution:

Lead time (weeks)	Frequency	Probability	Cumulative Probability
1	10	0.05	0.05
2	20	0.10	0.15
3	70	0.35	0.50
4	40	0.20	0.70
5	30	0.15	0.85
6	10	0.05	0.90
7	10	0.05	0.95
8	10	0.05	1.00
200			

Average lead time = $\frac{\sum (\text{lead time} \times \text{frequency})}{\sum \text{frequency}}$

$$= \frac{(10 + 40 + 210 + 160 + 150 + 60 + 70 + 80)}{200}$$

$$= \frac{770}{200} = 3.85 \text{ weeks}$$

Upto 90% service level max. lead time is 6 weeks.

Hence $6 - 3.85 = 2.15$ weeks of stock would provide the service level of 90%

(Note: If the lead time is given as a continuous time distribution take the mid point.)

Example: Demand for a product during an order period is assumed to be normally distributed with mean of 1000 units and standard deviation of 40 units. What % service can a company expect to provide (i) if it satisfies the average demand only (ii) if it carries a safety stock of 60 units.

Solution:

1. If the company provides only average demand, we can expect only 50% service level.
2. The standard normal variate Z is computed with the following formula.

$$Z = (\text{Safety stock} - 0) / \text{Standard deviation}$$

$$= (60 - 0) / 40 = 1.5$$

The area under normal curve for $Z = 1.5$ is 0.4332.

\therefore Service level = $0.50 + 0.4332 = 0.9332$ or 93.32%

Example: A manufacturer of water filters purchases components in EOQ's of 850 units/order. Total demand averages 12000 components per year and $MAD = 32$ units per month. If the manufacturer carries a safety stock of 80 units, what service level does this give the firm?

Solution:

$$\text{Standard deviation} = \sqrt{\frac{2}{\pi}} \times MAD = MAD / 0.8 = 32 / 0.8 = 40$$

$$Z = (S - 0) / S.D = (80 - 0) / 40 = 2$$

The area under normal curve for $Z = 2$ = 0.4772.

Service level = 0.9772 or 97.72%

Example: A firm has normally distributed forecast of usage with $MAD = 60$ units. It desires a service level, which limits the stock, out to one order cycle per year.

- (1) How much safety stock should be carried if the order quantity is normally a week's supply?
- (2) How much safety stock should be carried if the order quantity is weeks supply.

Solution:

No. of orders = 52/year.

1 stock out in 52 weeks means a 98 % = (51/52) values

For 98% area, the value of

$$Z = 2.05 \text{ (from tables)}$$

$$S.D = MAD / 0.8 = 60 / 0.8$$

$$Z = (S - 0) / S.D = (S - 0) / 60 / 0.8$$

$$2.05 = (S - 0) \times 0.8 / 60$$

$$SS = 2.05 \times 60 / 0.8 = 154 \text{ units.}$$

$$(a) \text{ Number of orders} = 52 / 5$$

$$1 \text{ stock out} = (52 / 5 - 1)$$

$$\text{Service level} = (47 / 5) / (52 / 5) = 47 / 52 = 0.904$$

$$Z = 1.285 \text{ (for area} = 0.404) \text{ } MAD = 60$$

$$1.285 = S / 75$$

$$S = 75 \times 1.285 = 96 \text{ units.}$$

4 Linear Programming

4.1 Introduction

Linear programming is a mathematical technique designed to aid managers in allocating scarce resources (such as labor, capital, or energy) among competing activities. It reflects, in the form of a model, the organization's attempt to achieve some objective (frequently, maximizing profit contribution, maximizing rate of return, minimizing costs) in view of limited or constrained resources (available capital or labor, service levels, available machine time, budgets).

The linear programming technique can be said to have a linear objective function that is to be optimized (either maximized or minimized) subject to linear equality or inequality constraints and sign restrictions on the variables. The term linear describes the proportionate relationship of two or more variables. Thus, a given change in one variable will always cause a resulting proportional change in another variable.

Some areas in which linear programming have been applied will be helpful in setting the climate for learning about this important technique.

- (i) A company produces agricultural fertilizers. It is interested in minimizing costs while meeting certain specified levels of nitrogen, phosphate, and potash by blending together a number of raw materials.
- (ii) An investor wants to maximize his or her rate of return by investing in stocks and bonds. The investor can set specific conditions that have to be met including availability of capital.
- (iii) A company wants the best possible advertising exposure among a number of national magazines, and radio and television commercials within its available capital requirements.
- (iv) An oil refinery blends several raw gasoline and additives to meet a car manufacturer's specifications while still maximizing its profits.
- (v) A city wants to maximize the daytime use of recreational properties being proposed for purchase with a limited capital available.

This technique, called linear programming (L.P), is solved in a step-by-step manner called iterations. Each step of the procedure is an attempt to improve on the solution until the "best answer" is obtained or until it is shown that no feasible answer exists.

4.2 Formulation of the Linear Programming Problem

To formulate a real-life problem as a linear program is an art in itself. To aid you in this task, it is helpful to isolate the essential elements of the problem as a means of asking what the clients wants and what information can be gained from the data that has been provided.

The first step in formulating a problem is to set forth the objective called the objective function.

A second element of a problem is that there are certain constraints on the company's ability to maximize the total contribution. These constraints are:

- (1) quantity of raw materials available,
- (2) the level of demand for the products, and
- (3) The equipment productive capacity.

A further element that must be considered in the problem is the time period being used. The duration may be either long term or short term. Although time is an important element, it is one that has flexibility so that the time horizon may be changed as long as the restrictions are compatible with the periods under consideration.

The last element is that every product has a likelihood of being made. These products are the dependent or decision variables. Of course, the likelihood of a variable's being in the answer may change with the price or contribution values (usually profit and the nature of the restraints). Yet, at this point there is nothing to indicate that differing chances of occurrence exists for the possibility of making each of the products.

The first stage of solving linear programming problems is to set forth the problem in a mathematical form by defining the variables and the resulting constraints. Generally, the relationship is fairly simple using only elementary algebraic notation. The relationships can be seen by first identifying the decision variables. To aid in using algebraic notation, the decision variables can be represented by symbols such as X, Y, Z.

Next, we must build the objective function. If the goal is to maximize profit, we identify our objective function as

Maximize total profit or Minimize total loss (cost).

Then we write problem constraints.

These steps are now illustrated by taking some examples.

4.2.1 Product Mix Problem

The Regal China Company produces two products daily plates and mugs. The company has limited amounts of two resources used in the production of these products clay and labor. Given these limited resources, the company desires to know how many plates to produce each day, in order to Maximize profit. The two products have the following resource requirements for production and profit per item produced (i.e., the model parameters).

Product	Labor (hours/unit)	Clay (lbs./unit)	Profit (Rs./unit)
Plate	1	4	4
Mug	2	3	5

There are 40 hours of labour and 120 pounds of clay available each day for production.

Formulate this problem as a linear programming model by defining each component of the model separately and then combining the components into a single model.

Decision Variables

The decision confronting management in this problem is how many plates and mugs to produce. As such, there are two decision variables that represent the number of plates and mugs to be produced on a daily basis. The quantities to be produced can be represented symbolically as,

X_1 = the number of plates to produce

X_2 = the number of mugs to produce

The Objective Function

The objective of the company is to Maximize total profit. The company's profit is the sum of the individual profits gained from each plate and mug. As such, profits from plates are determined by multiplying the unit profit for each plate, Rs. 4, by the number of plates produced, X_1 . Likewise, profit derived from mugs is the unit profit of a mug, Rs. 5, multiplied by the number of mugs produced, X_2 . Thus, total profit, Z , can be expressed mathematically as

$$\text{Maximize } Z = 4X_1 + 5X_2$$

where

Z = total profit per day

Rs $4X_1$ = profit from plates

Rs $5X_2$ = profit from mugs

By placing the term Maximize in front of the profit function, the relationship expresses the objective of the firm to Maximize total profit.

Model Constraints

This problem has two resources used for production, which are limited, labor and clay. Production of plates and mugs require both labor and clay. For each plate produce, one hour of labor is required. Therefore, the labor used for the production of plates is $1X_1$ hours. Similarly, each mug requires two hours of labor; the labor used for the production of mugs is $2X_2$ hours. Thus, the labor used by the company is the sum of the individual amounts of labor used for each product.

$$1X_1 + 2X_2$$

However, the amount of labor represented " $1X_1 + 2X_2$ " is limited to 40 hrs per day, thus, the complete labor constraint is

$$1X_1 + 2X_2 \leq 40 \text{ hours}$$

The "less than or equal to (\leq)" inequality is employed instead of an equality ($=$) because the forty hours of labor is a maximum limitation that can be used, but not an amount that must be used. This allows the company more flexibility in that it is not restricted to use the 40 hours exactly, but whatever amount necessary to Maximize profit up to and including forty hours. This means that the possibility of "idle or excess capacity" (i.e., the amount under forty hours not used) exists.

The constraint for pottery clay is formulated in the same way as the labor constraint. Since each plate requires four pounds of clay, the amount of clay used daily for the production of plates is $4X_1$ pounds, and since each mug requires three pounds of clay, the amount of clay used for mugs daily is $3X_2$. Given that amount of clay available for production each day is 120 pounds, the material constraint can be formulated as

$$4X_1 + 3X_2 \leq 120 \text{ pounds}$$

A final restriction is that the number of plates and mugs produced be either zero or a positive value, since it would be impossible to produce negative items. These restrictions are referred to as nonnegative constraints and are expressed mathematically as

$$X_1 \geq 0, X_2 \geq 0$$

The complete linear programming model for this problem can now be summarized as

$$\text{Maximize } Z = \text{Rs. } 4X_1 + 5X_2$$

$$\begin{aligned} \text{Subject to} \quad & 1X_1 + 2X_2 \leq 40 \\ & 4X_1 + 3X_2 \leq 120 \\ & X_1, X_2 \geq 0 \end{aligned}$$

The solution of this model will result in numerical values for X_1 and X_2 , which will maximize total profit, Z . As one possible solution, consider $X_1 = 5$ plates and $X_2 = 10$ mugs. First we will substitute this hypothetical solution into each of the constraints in order to make sure that the solution does not require more resources than the constraints show are available.

$$1(5) + 2(10) \leq 40 \quad 25 \leq 40$$

and

$$4(5) + 3(10) \leq 120 \quad 50 \leq 120$$

Thus, neither one of the constraints is violated by this hypothetical solution. As such, we say the solution is feasible (i.e., it is possible). Substituting these solution values in the objective function gives $Z = 4(5) + 5(10) = \text{Rs. } 70$. However, the maximum profit.

Now consider a solution of $X_1 = 10$ plates and $X_2 = 20$ mugs, this would result in a profit of

$$Z = \text{Rs. } 4(10) + 5(20) = 40 + 100 = \text{Rs. } 140$$

While this is certainly a better solution in terms of profit, it is also infeasible (i.e., not possible) because it violates the resource constraint or labor:

$$\begin{aligned} 1(10) + 2(20) &\leq 40 \\ 50 &\leq 40 \end{aligned}$$

Thus, the solution to this problem must both Maximize profit and not violate the constraints. The actual solution to this model which achieves this objective is $X_1 = 24$ plates and $X_2 = 8$ mugs, with a corresponding profit of Rs. 136.

4.2.2 Ingredients Mixing Problem

Fauji Foundation produces a cereal SUNFLOWER, which they advertise as meeting the minimum daily requirements for vitamins A and D. The mixing department of the company uses three main ingredients in making the cereal-wheat, oats, and rice, all three of which contain amounts of vitamin A and D. Given that each box of cereal must contain minimum amounts of vitamin A and D, the company has instructed the mixing department determine how many ounces of each ingredient should go into each box of cereal in order to minimize total cost.

This problem differs from the previous one in that its objective is to minimize cost, rather than Maximize profit.

Each ingredient has the following vitamin contribution and requirement per box.

VITAMIN CONTRIBUTION

Vitamin	Wheat (mg./oz.)	Oats (mg./oz)	Rice (mg./oz.)	Milligrams Required/Box
A	10	20	08	100
D	07	14	12	70

The cost of one ounce of wheat is Rs. 0.4, the cost of an ounce of oats is Rs. 0.6, and the cost of one ounce of rice is Rs. 0.2.

Decision Variables

This problem contains three decision variables for the number of ounces of each ingredient in a box of cereal:

X_1 = ounces of wheat

X_2 = ounces of oats

X_3 = ounces of rice

The Objective Function

The objective of the mixing department of the Fauji Foundation is to minimize the cost of each box of cereal. The total cost is the sum of the individual costs resulting from each ingredient. Thus, the objective function that is to minimize total cost, Z , is expressed as

$$\text{Minimize } Z = \text{Rs. } 0.4X_1 + 0.6X_2 + 0.2X_3$$

where Z = total cost per box

Rs. $0.4 X_1$ = cost of wheat per box

$0.6 X_2$ = cost of rice per box

$0.2 X_3$ = cost of rice per box

Model Constraints

In this problem the constraints reflect the requirements for vitamin consistency of the cereal. Each ingredient contributes a number of milligrams of the vitamin to the cereal. The constraint for vitamin A is

$$10 X_1 + 20 X_2 + 8 X_3 \geq 100 \text{ milligrams}$$

where $10 X_1$ = vitamin A contribution (in mg.) for wheat

$20 X_2$ = vitamin A contribution (in mg.) for oats

$8X_3$ = vitamin A contribution (in mg.) for rice

Notice that rather than an (\leq) inequality, as used in the previous example, this constraint requires a \geq (greater than or minimum requirement) specifying that at least 100 mg of vitamin A must be in a box. If a minimum cost solution results so that more than 100 mg is in the cereal mix, which is acceptable, however, the amount cannot be less than 100 mg.

The constraint for vitamin D is constructed like the constraint for vitamin A.

$$7X_1 + 14 X_2 + 12X_3 \geq 70 \text{ milligrams}$$

As in the previous problem there are also nonnegative constraints indicating that negative amounts of each ingredient cannot be in the cereal.

$$X_1, X_2, X_3 \geq 0$$

The L.P. model for this problem can be summarized as

$$\text{Minimize } Z = \text{Rs. } 0.4 X_1 + 0.6 X_2 + 0.2 X_3$$

$$\text{Subject to } 10X_1 + 20 X_2 + 8X_3 \geq 100$$

$$7 X_1 + 14 X_2 + 12 X_3 \geq 70$$

$$X_1, X_2, X_3 \geq 0$$

4.2.3 Investment Planning Problem

Mr. Majid Khan has Rs. 70, 000 to investment in several alternatives. The alternative investments are national certificates with an 8.5% return, Defence Savings Certificates with a 10% return, NIT with a 6.5% return, and khas deposit with a return of 13%. Each alternative has the same time until maturity. In addition, each investment alternative has a different perceived risk thus creating a desire to diversify. Majid Khan wants to know how much to invest in each alternative in order to maximize the return.

The following guidelines have been established for diversifying the investments and lessening the risk;

1. No more than 20% of the total investment should be in khas deposit.
2. The amount invested in Defence Savings Certificates should not exceed the amount invested in the other three alternatives.
3. At least 30% of the investment should be in NIT and Defence Savings Certificates.
4. The ration of the amount invested in national certificates to the amount invested in NIT should not exceed one to three.

Decision Variables

There are four decision variables in this model representing the monetary amount invested in each investment alternative.

X_1 = the amount (Rs.) invested in national certificates

X_2 = the amount (Rs.) invested in Defence Savings Cert.

X_3 = the amount (Rs.) invested in NIT.

X_4 = the amount (Rs.) invested in khas deposit.

The Objective Function

The objective of the investor is to maximize the return from the investment in the four alternatives. The total return is the sum of the individual returns from each separate alternative.

Thus, the objective function is expressed as

$$\text{Maximize } Z = \text{Rs. } .085 X_1 + .100 X_2 + .065 X_3 + .130 X_4$$

$$\text{Where } Z = \text{the total return from all investments}$$

Rs. $.085 X_1$ = the return from the investment in nat. Cer.

$.100 X_2$ = the return from the investment in certificates of deposit.

$.065 X_3$ = the return from the investment in NIT.

$.130 X_4$ = the return from the investment in khas deposit.

Model Constraints

In this problem the constraints are the guidelines established by the investor for diversifying the total investment. Each guideline will be transformed into a mathematical constraint separately.

Guideline one states that no more than 20% of the total investment should be in khas deposit. Since the total investment will be Rs. 70, 000 (i.e., the investor desires to invest the entire amount), then 20% of Rs. 70, 000 is Rs. 14, 000. Thus, this constraint is

$$X_4 \leq \text{Rs. } 14, 000$$

The second guideline indicates that the amount invested in Defence Savings Cert. should not exceed the amount invested in the other three alternatives. Since the investment in Defence Savings Cert. is X_2 and the amount invested in the other alternatives is $X_1 + X_3 + X_4$ the constraint is

$$X_2 \leq X_1 + X_3 + X_4$$

However, the solution technique for linear programming problems will require that constraints be in a standard form so that all decision variables are on the left side of the inequality (i.e., \leq) and all numerical values are on the right side. Thus, by subtracting, $X_1 + X_3 + X_4$ from both sides of the sign, this constraint in proper form becomes

$$X_2 - X_1 - X_3 - X_4 \leq 0$$

Thus third guideline specifies that at least 30% of the investment should be in NIT and Defence Savings Certificates. Given that 30% of the Rs. 70, 000 totals is Rs. 21, 000 and the amount invested in Defence Savings Certificates and NIT is represented by $X_2 + X_3$, the constraint is,

$$X_2 + X_3 \geq \text{Rs. } 21, 000$$

The fourth guideline states that the ratio of the amount invested in national certificates to the amount invested in NIT should not exceed one to three. This constraint is expressed as

$$(X_1) / (X_3) \leq 1/3$$

This constraint is not in standard linear programming form because of the fractional relationship of the decision variables, X_1/X_3 . It is converted as follows;

$$X_1 \leq 1 X_3/3$$

$$3X_1 - X_3 \leq 0$$

Finally, Majid Khan wants to invest all of the Rs. 70, 000 in the four alternatives. Thus, the sum of all the investments in the four alternatives must equal Rs. 70, 000,

$$X_1 + X_2 + X_3 + X_4 = \text{Rs. } 70, 000$$

This last constraint differs from the \leq and \geq inequalities previously developed, in that a specific requirement exists to invest an exact amount. Thus, the possibility of investing more than Rs. 70, 000 or less than Rs. 70, 000 is not considered.

This problem contains all three of the types of constraints that are possible in a linear programming problem: \leq , $=$ and \geq . Further, note that there is no restriction on a model containing any mix of these types of constraints as demonstrated in this problem.

The complete LP model for this problem can be summarized as

$$\begin{aligned} \text{Maximize} \quad & Z = .085X_1 + .100X_2 + .065X_3 + .130X_4 \\ \text{Subject to} \quad & X_4 \leq 14,000 \\ & X_2 - X_1 - X_3 - X_4 \leq 0 \\ & X_2 + X_3 \geq 21,000 \\ & 3X_1 - X_3 \leq 0 \\ & X_1 + X_2 + X_3 + X_4 = 70,000 \\ & X_1, X_2, X_3, X_4, \geq 0 \end{aligned}$$

4.2.4 Chemical Mixture Problem

United Chemical Company produces a chemical mixture for a customer in 1, 000 - pound batches. The mixture contains three ingredients - zinc, mercury, and potassium. The mixture must conform to formula specifications (i.e., a recipe) supplied by the customer. The company wants to know the amount of each ingredient to put in the mixture that will meet all the requirements of the mix and minimize total cost.

The formula for each batch of the mixture consists of the following specifications:

1. The mixture must contain at least 200 lbs. of mercury.
2. The mixture must contain at least 300 lbs. of zinc.
3. The mixture must contain at least 100 lbs. of potassium.

The cost per pound for mercury is Rs. 4; for zinc, Rs. 8; and for potassium, Rs. 9.

Decision Variables

The model for this problem contains three decision variables representing the amount of each ingredient in the mixture:

X_1 = the number of lbs. of mercury in a batch.

X_2 = the number of lbs. of zinc in a batch.

X_3 = the number of lbs. of potassium in a batch.

The Objective Function

The objective of the company is to minimize the cost of producing a batch of the chemical mixture. The total cost is the sum of the individual costs of each ingredient:

$$\text{Minimize } Z = \text{Rs. } 4X_1 + 8X_2 + 9X_3$$

where

Z = the total cost of all ingredients

Rs. $4X_1$ = the cost of mercury in each batch
 $8X_2$ = the cost of zinc in each batch
 $9X_3$ = the cost of potassium in each batch.

Model Constraints

In this problem the constraints are derived for the chemical formula.

The first specification indicates that the mixture must contain at least 200 lbs. of mercury,

$$X_1 \geq 200$$

The second specification is that the mixture must contain at least 300 lbs. of zinc,

$$X_2 \geq 300$$

The third specification is that the mixture must contain at least 100 lbs. of potassium,

$$X_3 \geq 100$$

Finally, it must not be over looked that the whole mixture relates to a 1, 000-lb. batch. As such, the sum of all ingredients must exactly equal 1, 000 lbs.,

$$X_1 + X_2 + X_3 = 1, 000$$

The complete linear programming model can be summarized as

$$\text{Minimize } Z = 4X_1 + 8X_2 + 9X_3$$

$$\text{Subject to } X_1 \geq 200$$

$$X_2 \geq 300$$

$$X_3 \geq 100$$

$$X_1 + X_2 + X_3 = 1, 000$$

$$X_1, X_2, X_3 \geq 0$$

4.2.5 Marketing Problem

The Bata Shoe Company has contracted with an advertising firm to determine the types and amount of advertising it should have for its stores. The three types of advertising available are radio and television commercials and newspaper ads. The retail store desires to know the number of each type of advertisement it should purchase in

order to Maximize exposure. It is estimated that each ad and commercial will reach the following potential audience and cost the following amount.

Type of Advertisement	Exposure (people/ad or commercial)	Cost
Television commercial	20, 000	Rs. 15, 000
Radio commercial	12, 000	6, 000
Newspaper ad	9, 000	4, 000

The following resource constraints exist:

1. There is a budget limit of Rs. 100,000 available for advertising.
2. The television station has enough time available for four commercials.
3. The radio station has enough time available for ten radio commercials.
4. The newspaper has enough space available for seven ads.
5. The advertising agency has time and staff to produce at most a total of fifteen commercials ads.

Decision Variables

This model consists of three decision variables representing the number of each type of advertising produced:

X_1 = the number of television commercials

X_2 = the number of radio commercials

X_3 = the number of newspaper ads

The Objective Function

The objective of this problem is different from the objectives in the previous examples in which only profit was Maximized (or cost minimized). In this problem profit is not Maximized, but rather the audience exposure is Maximized.

This objective function demonstrates that although a linear programming model must either Maximize or Minimize some objective, the objective itself can be in terms of any type of activity or valuation.

For this problem the objective of audience exposure is determined by summing the audience exposure gained from each type of advertising

Maximize $Z = 20,000 X_1 + 12,000 X_2 + 9,000 X_3$

Where Z = the total number of audience exposures

$20,000 X_1$ = the estimated number of exposures from television commercials

$12,000 X_2$ = the estimated number of exposures from radio commercials

$9,000 X_3$ = the estimated number of exposures from newspaper ads

Model Constraints

The first constraint in this model reflects the limited budget of Rs. 100, 000 allocated for advertisement,

$$\text{Rs. } 15,000 X_1 + 6,000 X_2 + 4,000 X_3 \leq 100,000$$

where

Rs. 15, 000 X_1 = the amount spent for television advertising

6, 000 X_2 = the amount spent for radio advertising

4, 000 X_3 = the amount spent for newspaper advertising

The next three constraints represent the fact that television and radio commercials are limited to four and ten, respectively, while newspaper ads are limited to seven.

$$X_1 \leq 4 \text{ commercial}$$

$$X_2 \leq 10 \text{ commercials}$$

$$X_3 \leq 7 \text{ ads}$$

The final constraint specifies that the total number of commercials and ads cannot exceed fifteen due to the limitations of the advertising firm:

$$X_1 + X_2 + X_3 \leq 15 \text{ commercials and ads}$$

The complete linear programming model for this problem is summarized as

$$\text{Maximize } Z = 20,000 X_1 + 12,000 X_2 + 9,000 X_3$$

Subject to

$$\text{Rs. } 15,000 X_1 + 6,000 X_2 + 4,000 X_3 \leq \text{Rs. } 100,000$$

$$X_1 \leq 4$$

$$X_2 \leq 10$$

$$X_3 \leq 7$$

$$X_1 + X_2 + X_3 \leq 15$$

$$X_1, X_2, X_3 \geq 0$$

4.2.6 Transportation Problem

The Philips Television Company produces and ships televisions from three warehouses to three retail stores on a monthly basis. Each warehouse has a fixed demand per month. The manufacturer wants to know the number of television sets to ship from each warehouse to each store in order to minimize the total cost of transportation.

Each warehouse has the following supply of televisions available for shipment each month.

Warehouse	Supply (sets)
1. Karachi	300

2. Lahore	100
3. Islamabad	200

	600

Each retail store has the following monthly demand for television sets:

Store	Demand (sets)
A. Faisalabad	150
B. Peshawar	250
C. Hyderabad	200

	600

The costs for transporting television sets from each warehouse to each retail store are different as a result of different modes of transportation and distances. The shipping costs per television set for each route are,

From Warehouse	To store		
	A	B	C
1	Rs. 6	Rs. 8	Rs. 1
2	4	2	3
3	3	5	7

Decision Variables

The model for this problem consists of nine decision variables representing the number of television sets transported from each of the three warehouses to each of the three stores,

X_{ij} = the No. of television sets shipped from warehouse "i" to store "j" where $i = 1, 2, 3$ and $j = A, B, C$.

X_{ij} is referred to as a double subscripted variable. However, the subscript, whether double or single simply gives a "name" to the variable (i.e., distinguishes it from other decision variables). As such, the reader should not view it as more complex than it actually is. For example, the decision variable X_{3A} Islamabad to store A in Faisalabad.

The Objective Function

The objective function of the television manufacturer is to minimize the total transportation costs for all shipments. Thus, the objective function is the sum of the individual shipping costs from each warehouse to each store.

$$\text{Minimize } Z = \text{Rs. } 6X_{1A} + 8X_{1B} + 1X_{1C} + 4X_{2A} + 2X_{2B} + 3X_{2C} + 3X_{3A} + 5X_{3B} + 7X_{3C}$$

Model Constraints

The constraints in this model are available television sets at each warehouse and the number of sets demanded at each store. As such, six constraints exist -- one for each warehouse's supply and one for each store's demand. For example, warehouse 1 retail stores. Since the amount shipped to the three stores is the sum of X_{1A} , X_{1B} , and X_{1C} the constraint for warehouse 1 is

$$X_{1A} + X_{1B} + X_{1C} = 300$$

This constraint is an equality (=) for two reasons. First, more than 300 television sets cannot be shipped, because that is cannot be shipped, because all 300 are needed at the three stores, the three warehouses must supply all that can be supplied. Thus, since the total shipped from warehouse 1 cannot exceed 300 or be less than 300 the constraint is equality. Similarly, the other two supply constraints for warehouse 2 and 3 are also equalities.

$$X_{2A} + X_{2B} + X_{2C} = 100$$

$$X_{3A} + X_{3B} + X_{3C} = 200$$

The three demand constraints are developed in the same way except that television sets can be supplied from any of the three warehouses. Thus, the amount shipped to one store is the sum of the shipments from the three warehouses:

$$X_{1A} + X_{2A} + X_{3A} = 150$$

$$X_{1B} + X_{2B} + X_{3B} = 250$$

$$X_{1C} + X_{2C} + X_{3C} = 200$$

The complete linear programming model for this problem is summarized as:

$$\text{Minimize } Z = \text{Rs. } 6X_{1A} + 8X_{1B} + 1X_{1C} + 4X_{2A} + 2X_{2B} + 3X_{2C} + 3X_{3A} + 5X_{3B} + 7X_{3C}$$

subject to

$$X_{1A} + X_{1B} + X_{1C} = 300$$

$$X_{2A} + X_{2B} + X_{2C} = 100$$

$$X_{3A} + X_{3B} + X_{3C} = 200$$

$$X_{1A} + X_{2A} + X_{3A} = 150$$

$$X_{1B} + X_{2B} + X_{3B} = 250$$

$$X_{1C} + X_{2C} + X_{3C} = 200$$

$$X_{ij} \geq 0$$

4.3 General form of Linear Programming Problem

Let x_i = decision variable for i th variable.
 c_i = profit or cost co-efficient of i th variable.
 Z = function to be maximized or minimized.

Thus for n decision variables, the objective function is to maximize or minimize

$$Z = c_1 x_1 + c_2 x_2 + \dots + c_n x_n$$

Let a_{ij} = co-efficient of the j th constraint and i th variable
 b_i = resource limitation for i th constraint

Thus the restrictions may be expressed in the general form

8. A company makes products *A*, *B*, *C* and *D* which flow through four departments: Drilling, Milling, Lathe and Assembly. The variable time per unit of different products are given below in hours:

Product	Drilling	Milling	Lathe	Assembly
A	3	0	3	4
B	7	2	4	6
C	4	4	0	5
D	0	6	5	3

The unit contribution of the four products and hours of availability in the four departments are:

Product	Contribution/Unit Rs.	Department	Hours Available
A	9	Drilling	70
B	18	Milling	80
C	14	Lathe	90
D	11	Assembly	100

Formulate a linear programme for maximizing the contribution.

9. A pension fund manager is considering investing in two shares *A* and *B*. It is estimated that:

- Share *A* will earn a dividend of 12% per annum and share *B* 4 % per annum.
- Growth in the market value in one year of share will be 10 paise per Re. 1 invested and in *B* 40 paise per Re. 1 invested.

He requires investing the minimum total sum, which will give

- dividend income of at least Rs. 600 per annum and
- growth in one year of atleast Rs. 1000 on the initial investment.

You are required to state the mathematical formulation of the problem.

10. A manufacturer uses three raw products *a*, *b*, *c* priced at 30, 50, 120 rupees per kg respectively. He can make three different products *A*, *B* and *C*, which can be sold at 90, 100, 120 rupees per kg respectively. The raw products can be obtained only in limited quantities, namely 20, 15 and 10 kg per day. Given: 2 kg of *a* plus 1 kg of *b* plus 1 kg of *c* will yield 4 kg of *A*; 3 kg of *a* plus 2 kg of *b* plus 2kg of *c* will yield 7 kg of *B*; 2kg of *b* plus 1 kg of *c* will yield 3 kg of *C*.

Make a production plan, assuming that the other costs are not influenced by the choice among the alternatives. Formulate the model of the problem.

11. A marketing manager wishes to allocate his annual advertising budget of Rs. 20,000 in two media vehicles *A* and *B*. The unit of a message in media *A* is Rs. 1000 and that of *B* is Rs. 1500, Media *A* is a monthly magazine and not more than one insertion is desired in one issue. At least 5 messages should appear in media *B*. The expected effective audience for unit messages in the media *A* is 40, 000 and media *B* is 55, 000.

- Develop a mathematical model.

- Solve for maximizing the total effective audience.
12. A company produces four products 1 to 4. Raw material requirements, storage space needed, production rates and profits are given in the table below. The total amount of raw material available per day for all four products is 180 kg, total space available for storage is 230 sq. mtr. and 7 hours/day is used for production.

	1	2	3	4
Raw materials (Kg/piece)	2	2	1.5	4
Space (sq. mtr./piece)	2	2.5	2	1.5
Production rate (pieces/hr)	15	30	10	15
Profit (Rs./piece)	55	56.6	55	55.5

How many units of each product should be produced to maximize total profit?

13. A ship has three cargo holds, forward, aft and centre.

The capacity limits are:

Forward	2000 tons	1000 cubic meter
Centre	3000 tons	1350 cubic meter
Aft	1500 tons	300 cubic meter

The following cargoes are offered; the ship owners may accept all or any part of each commodity.

Commodity	Amount (tons)	Volume/ton (cubic meter)	Profit/ton (Rs.)
A	6000	60	600
B	4000	50	800
C	2000	25	500

In order to preserve the trim of the ship, the weight in each hold must be proportional to the capacity in tons.

How should cargo be distributed so as to maximize profit? (only formulation of the problem needed).

4.4 Limitations of Linear Programming

We shall see the underlying assumptions of linear programming that limit its application.

4.4.1 Proportionality

A prerequisite in formulating the objective function and the constraints in a linear programming model is the linearity. This means that the measure of effectiveness and the usage of resources available must be proportional to the level of each activity decided individually. But in real life situations there are many problems, which are non-linear, and the solution to such problems is obtainable for some special cases only. Sometimes it is possible to convert the non-linear programming problem into the linear programming model so that the simplex method can very well be employed; but this is not always possible.

In certain linear programming problems, it may appear that the problem is completely linear but sometimes deceiving. It is not always problem is completely linear but sometimes deceiving. It is not always true that both the marginal measure of effectiveness and the marginal usage of each resource will be constants over the complete or

entire range of levels of each activity. For example if the production level changes in an industry, the profit or the man-hours required per unit of the level of the activity may change. In other words the coefficients in the objective function and the coefficients of the constraints may suffer a change.

Another type of nonlinear entering is what we call the fixed charge problem. This happens whenever there is a 'set up' cost associated with an activity. If x be the level of the activity and Δ be

$$\Delta = \begin{cases} 0 & \text{if } x = 0 \\ Ax + B & \text{if } x \geq 0 \end{cases}$$

Where A is the fixed charge coupled with any positive level of the activity. Since Δ is not a linear function of x over its entire range because of sudden increase at $x = 0$. Hence this poses the objection to include in the linear programming model.

4.4.2 Additivity

Let the measure of effectiveness and each resource usage is directly proportional to the level of each activity selected individually. This does not ensure linearity. A case of non-linearity may arise if there are joint interactions between some of the activities regarding the total measure of effectiveness or the total usage of some resource. Hence it is required that the additives be additive with respect to the measure of effectiveness and each resource usage. This implies that the total measure of effectiveness and each total resource usage required for the joint performance of the activities must be equal to the respective sums of these quantities resulting from each activity being considered individually.

This idea can be illustrated with an example. Let a company manufacture two items. Suppose that the profit would be c_1x_1 if the first item is produced at a level of x_1 , and the second item is not produced at all (i.e.) $x_2 = 0$ and that c_2x_2 would be the profit by producing the second item only at a level of x_2 and the first item is not produced at all (i.e.) $x_1 = 0$. These two products are additive with respect to profits, only if the total profit would be $c_1x_1 + c_2x_2$ when both $x_1 = 0$ and $x_2 = 0$. This would not be true if prices are lowered in order to sell both x_1 and x_2 instead of just one or the other.

Two activities not additive with respect to resource usage would be, when a by-product is produced with the scrap material from the primary item. This material would still have to be purchased if only one of the two items were produced. If both the items are produced, the total requirement is less than the sum of the requirements, if each were produced individually.

4.4.3 Divisibility

Many times we come across cases where the optimal solution leads to a non-integer value of the decision variables. But if the decision variables represent the number of items produced, it would have physical significance only if they turn out to be integer values. We cannot produce non-integral values. The solution procedure need decision variable must be permissible in order to get an optimal solution. This is what is referred to as an 'integer programming problem'. Anyhow solution procedure is still employed when an integer solution is required. Suppose we use the simplex method to obtain the solution to an integer-programming problem. If the procedure yields an optimal solution with integer value for the decision variables, then this will be the desired solution to the problem referred. If we do not get an integer solution to the problem, one option is to round it off to the nearest integer value. This may lead to some difficulties. First the integer rounded off to the nearest integer need not be feasible. Second, even if it is feasible, this solution may not be too near optimality. Considerable progress has been made recently in developing the solution to integer programming problem leading to optimum integer solution.

4.4.4 Deterministic

In formulating the linear programming model for a problem, the coefficients of profit or cost, constraints and resource availability or usage are assumed to be constants known. In real life, they may not be known completely and they may be liable for changes from time to time. Sometimes it is difficult to predict the precise value of these coefficients. Linear programming models are developed to predict the future solution in which these coefficients must be known exactly to get the solution. These coefficients may sometimes be random variables following a certain probability distribution.

A number of approaches is sometimes used when some of the coefficients are not known. Sometimes we go in for sensitivity analysis, an extension of sensitivity analysis known as parametric programming and also chance constrained linear programming model.

4.5 Solution to Linear Programming Problems

Having formulated a linear programming problem, we have to find the solution for the same. To find the solution to a linear programming model, we have the graphical and the algebraic methods that can be applied successfully.

If the problem involves only two decision variables, graphical method of solution is quite adequate. Even when three decision variables are involved, a graphical solution can be resorted to. But this involves three-dimensional representation. Therefore we can conveniently restrict the graphical method to problems involving two decision variables.

The second method is the algebraic procedure or simplex method, which involves an iterative procedure. This can be applied to linear programming problems involving two or more variables. This is the most versatile method of solving linear programming models. In this method, an initial solution is assumed and this solution is modified progressively through a well-defined iterative process until we get the optimal solution. The procedure is simple and so mechanical that it requires time and patience to execute it manually. However, an electronic computer with the readymade programmes can be used as a handy tool for solving LP problems involving many variables.

4.6 Graphical solution to LPP

We all know that a point can be represented by two co-ordinates namely x and y in a graph. From the origin we have to go x units along x axis and y units along y -axis. If we plot two points in a graph and join them we get a segment of a straight line. A minimum of two points is needed to draw a straight line. In a linear programming problem, the objective function and constraints are linear, so that we can plot the straight lines representing constraints and the objectives function.

Let us take an algebraic equation $3x + 5y = 15$. This is a first-degree equation in x and y . Geometrically this represents a straight line. If we want to represent the above equation geometrically, we require a minimum of two points to plot a line. Let $x = 0$, we get $y = 3$ and let $y = 0$ we get $x = 5$. Hence we have two points $A(0, 3)$ and $B(5, 0)$ and connect them to get a straight line

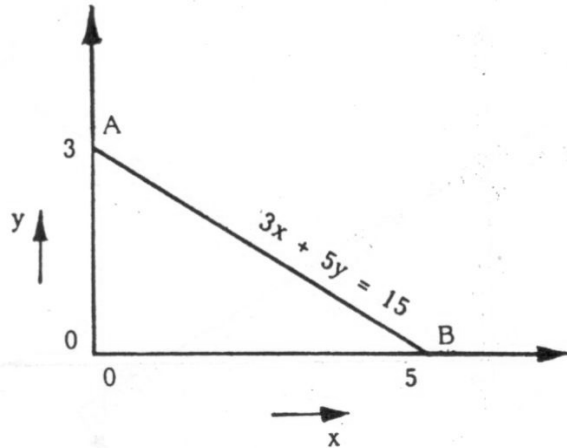

Fig 1

We normally come across, in linear programming problems, the linear constraints having inequalities either 'greater than equal to' or 'less than equal to' or strictly 'equal to'.

Consider the inequality $3x + 5y \leq 15$

To plot the feasible area satisfying the above inequality, we consider the equation $3x + 5y = 15$.

This has been plotted in the figure 1. This straight line has an area above the line and an area below the line. To determine the appropriate area satisfying the inequality, $3x + 5y \leq 15$,

Let us consider the origin ($x = 0, y = 0$) as a reference point. Left hand side for the reference point is $3 \cdot 0 + 5 \cdot 0 = 0$.

The value '0' of the left hand side is clearly less than 15 satisfying the constraint and therefore the origin whose co-ordinates are (0, 0) is a point to be included in the feasible area. The origin is below the straight line and the area A_1 should also contain the trial point namely the origin. Hence the feasible area satisfying the constraint $3x + 5y \leq 15$ is indicated as A_1 in figure 2.

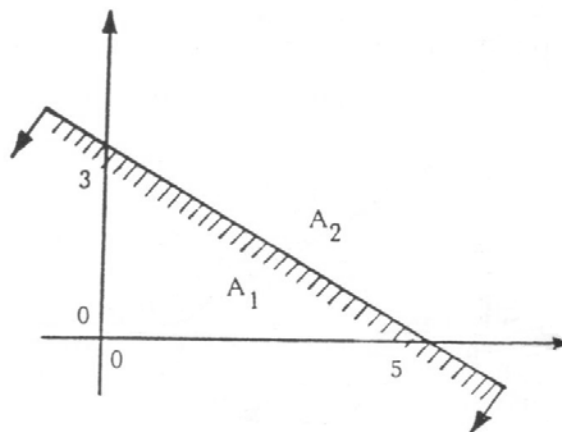

Fig. 2

Next consider the inequality $3x + 5y \geq 15$

To find the feasible area satisfying the above inequality, we take once again the origin as a trial point and see whether this has to be included in the area. Let $x = 0$ and $y = 0$, then we get the value of the left hand side is 0 and the right hand side is 15 and hence the area satisfying this space inequality $3x + 5y \geq 15$, should not contain the origin and hence the feasible solution space is as indicated by A_2 in figure 3.

The constraints are linear in a linear programming problem, which can be plotted on a graph. The ingenuity of graphical solution to a linear programming problem depends on fixing the proper solution space.

Consider the following inequality $4x - 5y \leq 20$

To get the feasible space to satisfy the above constraint, first we plot the straight line $4x - 5y = 20$ as shown in figure 4. The origin, which satisfies the constraint, should be included in the solution space.

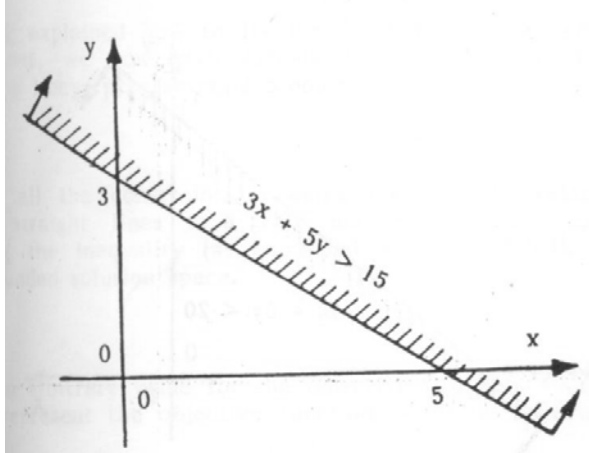

Fig. 3

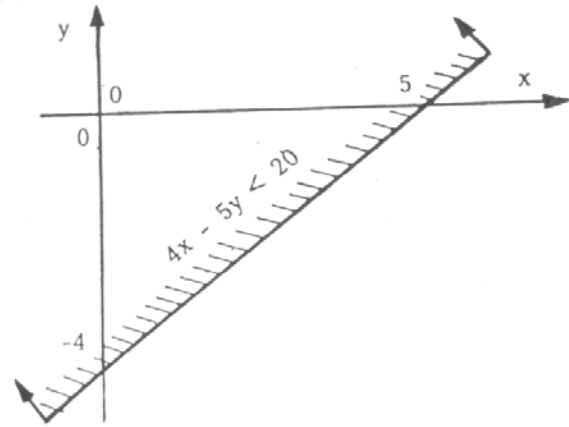

Fig. 4

Hence the area above the straight line shows the feasible solution space satisfying the inequality $4x - 5y < 20$. The area below the line will correspond to the constraint $4x - 5y \geq 20$.

Consider the inequality $-4x + 5y \leq 20$

We plot the straight line $-4x + 5y = 20$ as shown in figure 5

The origin satisfies the inequality $-4x + 5y < 20$ and this should be included in the feasible solution space. Hence the area below the straight line should represent the feasible solution space

Consider the inequality $-4x - 5y \leq 20$

We plot the straight line $-4x - 5y = 20$ as shown in figure 6

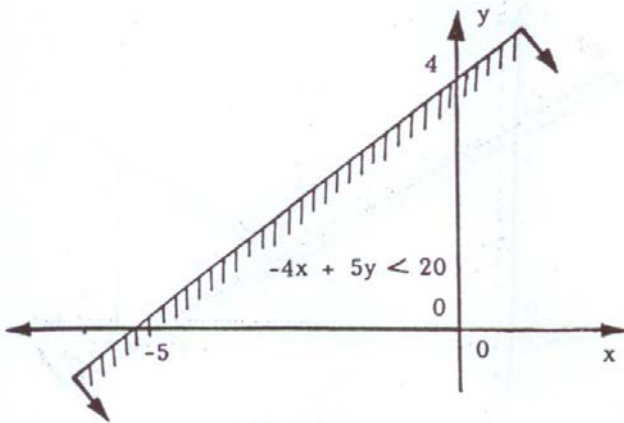

Fig 5

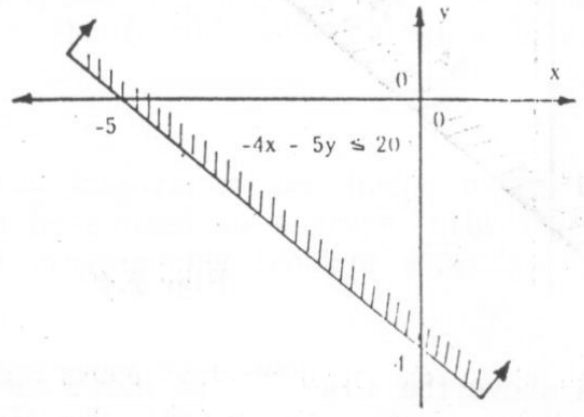

Fig. 6

Since the origin satisfies the inequality $-4x - 5y = 20$ it should be included in the feasible solution space. Hence the area above the straight line should be the solution space.

4.6.1 Procedure for Graphical Solution to LPP

Having explained how to fix the feasible solution space satisfying the constraint, we now give various steps involved in arriving at a solution to a linear programming problem.

STEP 1: Consider all the constraints. Taking the equality relationship, plot all the straight lines in a graph and get feasible solution space satisfying the inequality. Usually we get a bounded solution space.

STEP 2: Assign an arbitrary value for the objective function. Plot the straight line to represent the objective function, with the arbitrary value for Z .

STEP 3: Move the objective line parallel in the appropriate direction in the solution space to maximize and in the opposite direction to minimize the objective function under consideration.

STEP 4: In this process, the moving objective line may meet an extreme point (or corner point) beyond which we cannot proceed as this violates the constraints. Note the co-ordinates of this extreme point, which will give maximum or minimum value of the objective function.

The above steps are explained in the following example.

Example

$$\text{Maximize } Z = 4x + 7y$$

$$\text{Subject to } x \leq 40, \quad y \leq 30, \quad x + y \leq 60, \quad x, y \geq 0$$

In the above example, we have three constraints and all of them are 'less than inequalities'. First step in the graphical method of solution to the linear programming problem is to represent the constraints graphically. Consider the first constraint

$$x \leq 40$$

This indicates that x can take a value 40 or less than 40, for all values of y . The equation $x = 40$ is a straight line parallel to the y axis as in the figure 2.7 and the area to the left of this straight line is the solution space satisfying the constraint $x \leq 40$.

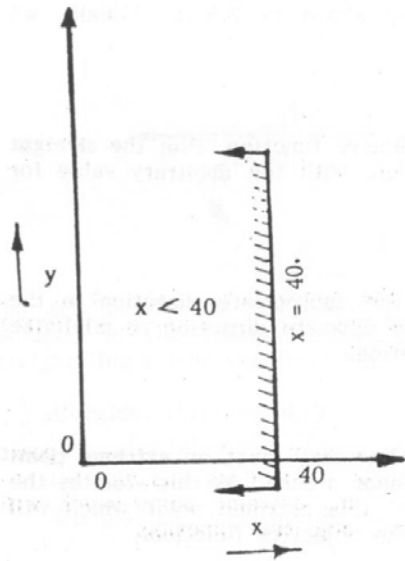

Fig. 7

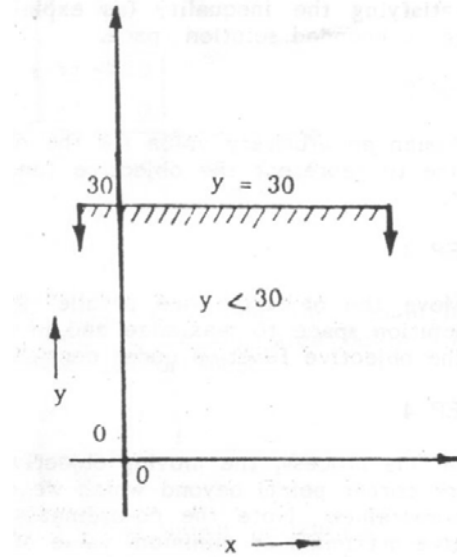

Fig. 8

Consider the second constraint $y \leq 30$. This demands that y can take a value of 30 or less than 30 for all the values of x . The equation $y = 30$ is a line parallel to x -axis and is represented in figure 8.

Similarly consider the third constraint $x + y \leq 60$. To plot the straight line let $x = 0$, then $y = 60$ and let $y = 0$, then $x = 60$. Therefore the two points $(0, 60)$ and $(60, 0)$ represented in figure 9 will be connected, to get the straight line $x + y = 60$. To get the solution space satisfying $x + y \leq 60$, let $x = 0$ and $y = 0$, then the left hand side reduces to 0 which is clearly less than 60. Therefore the area below the line including $(0, 0)$ represented by the shaded portion in figure 9 represents the solution space satisfying the constraint $x + y = 60$.

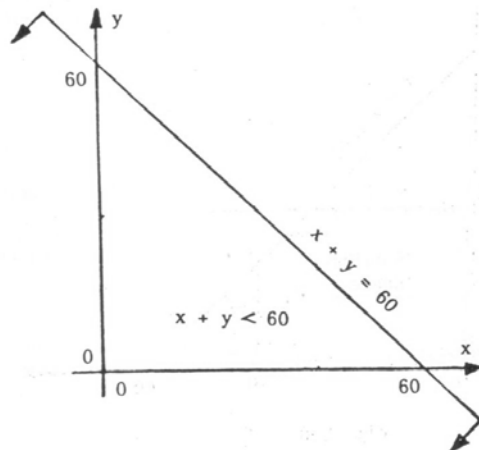

Fig. 9

Consider the non-negative constraints for x and y , and the feasible solution space is obtained by combining all the constraints in one figure as shown in figure 10.

The shaded portion of the figure 10 represents the solution space as feasible region. The solution space in figure 10 is a bounded figure with five corner points (otherwise called extreme points) namely A, B, C, D and E. The solution space is bounded by segments of five straight lines. The co-ordinates of A, B, C, D and E are determined by solving the appropriate simultaneous constraint equations.

Thus we have A at the origin, having co-ordinates $x = 0, y = 0$.

The co-ordinates for B are $x = 0, y = 30$.

The co-ordinates of C are found by solving equations:

$$y = 30 \quad x + y = 60$$

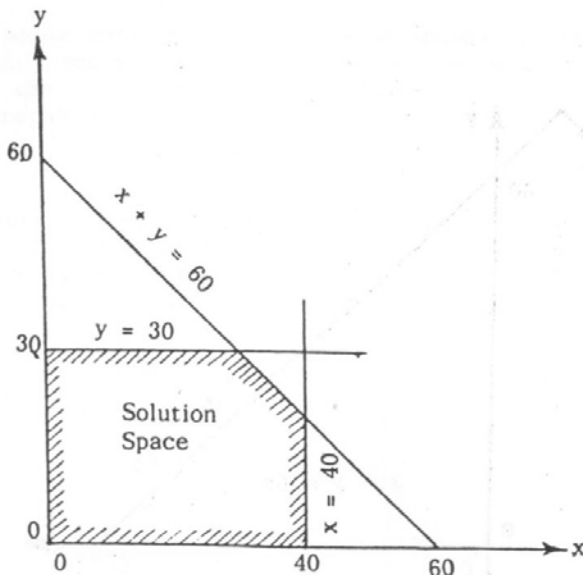

Fig 10

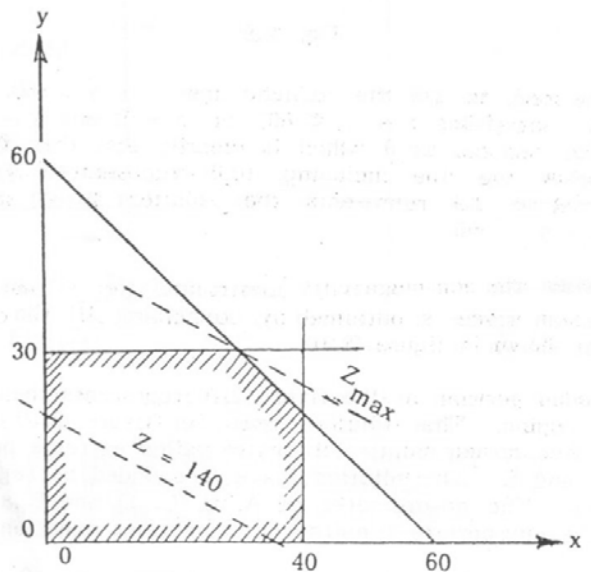

Fig 11

We get the co-ordinates of C as $x = 30, y = 30$.

Similarly the co-ordinates of D are determined by solving equations:

$$x = 40 \\ x + y = 60$$

The co-ordinates of D are $x = 40, y = 20$

The co-ordinates of E are $x = 40, y = 0$.

The next step is to examine the value of the objective function at these points. This is done in the table below:

Extreme point or corner point	Co-ordinates	Value of $Z = 4x + 7y$
A	(0, 0)	0
B	(0, 30)	210

C	(30, 30)	330*
D	(40, 20)	300
E	(40, 0)	160

From the above table we see that the objective function has a maximum value of 330 at C (30, 30). So, the optimum Z denoted by Z^* is given by $Z^* = 330$ for $x = 30$ and $y = 30$.

Alternate Method:

Instead of evaluating the objective function at all the extreme points; a graphical optimum solution can be obtained which is explained below.

Consider the objective function

$$Z = 4x + 7y$$

Assign a convenient arbitrary value for Z say $Z = 140$, then

$$Z = 4x + 7y = 140$$

This is a straight line, which can be represented in the solution space as shown in figure 11.

Consider $Z = 4x + 7y = 140$. If $x = 0$, we get $y = 20$ and if $y = 0$, we get $x = 35$. These two points are connected by a straight line representing $Z = 140$.

Thus $Z = 140$ is called an iso-profit line since for all points in the straight line, $Z = 140$. With this value we have obtained the slope and hence shape of the straight line.

Next step is to draw straight lines parallel to $4x + 7y = 140$.

This results in moving the objective line with various values in the solution space in a proper direction (upwards in this example for maximization and downwards for minimization). In this process, the objective line may cross a corner point indicating the maximum or minimum value.

Drawing parallel lines we see that a line passing through C (30, 30) gives the maximum value for Z and value of $Z^* = 330$.

Example

Minimize $Z = 4x + 5y$

Subject to $x + y \geq 10$
 $2x + 5y \geq 35$
 $x, y \geq 0$

Solution

STEP 1 Represent the constraints graphically

Consider $x + y = 10$
 If $x = 0$, then $y = 10$
 If $y = 0$, then $x = 10$

Consider $2x + 5y = 35$
 If $x = 0$, then $y = 7$
 If $y = 0$, then $x = 17.5$

The above constraints are represented in figure 12.

STEP 2: Mark the solution space in the graph satisfying all the constraints.

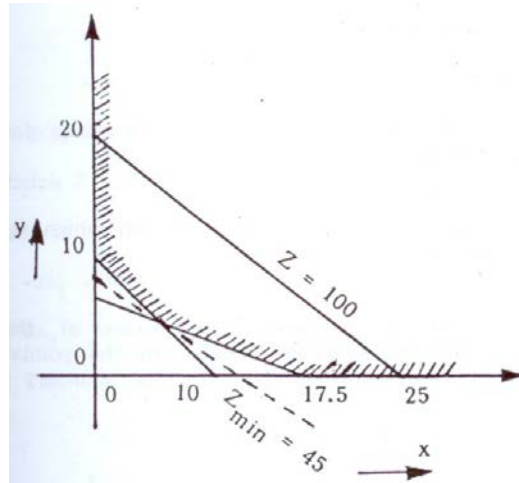

Fig. 12

STEP 3: Choose an arbitrary value of Z , say 100. Then

$$\begin{aligned} Z &= 4x + 5y = 100 \\ \text{If } x &= 0, \text{ then } y = 20 \\ \text{If } y &= 0, \text{ then } x = 25 \end{aligned}$$

Represent $Z = 100$ in the graph.

Move down the line $Z = 100$ to minimize the total cost Z . Thus we get the minimum value of Z at the point B , which is the intersection of two lines:

$$\begin{aligned} x + y &= 10 \\ 2x + 5y &= 35 \end{aligned}$$

Solving the two equations, we get $x = 5, y = 5$

RESULT: The minimum value of $Z = 4 \times 5 + 5 \times 5 = 45$, Therefore, $Z^* = 45, x = 5, y = 5$

4.7 Certain Definitions

1. A feasible solution is the value of all points for which all constraints are satisfied.
2. An optimal solution is a feasible solution, which maximizes or minimizes the objective function.

These terms can be interpreted in terms of the graphical representation. The feasible solution includes all the points within the permissible region (or solution space) including the boundary points.

4.7.1 Exercise

Solve Graphically

1. Maximize $Z = 3x + 7y$

Subject to $x + 4y \leq 20$
 $2x + y \leq 30$
 $x + y \leq 8$
 and $x, y \geq 0$

2. Maximize $Z = 2x + 3y$

Subject to $-x + 2y \leq 16$
 $x + y \leq 24$
 $x + 3y \geq 45$
 $-4x + 10y \geq 20$
 and $x, y \geq 0$

3. Maximize $Z = 3x_1 + 5x_2$

Subject to $-3x_1 + 4x_2 \leq 12$
 $2x_1 - x_2 \geq -2$
 $2x_1 + 3x_2 \geq 12$
 $x_1 \leq 4$
 $x_2 \geq 2$
 $x_1 \geq 0$

4. Maximize $Z = 4x_1 + 6x_2$

Subject to $x_1 \leq 2$
 $x_2 \leq 4$
 $x_1 + x_2 \geq 3$
 and $x_1, x_2 \geq 0$

5. What are the four major types of allocation problems, which could be solved using linear programming technique? Briefly explain each one of them with an example.

b) Minimize $Z = 4x_1 + x_2$
 Subject to $3x_1 + 4x_2 \geq 20$
 $-x_1 - 5x_2 \leq -15$
 and $x_1, x_2 \geq 0$

6. The standard weight of a brick is 5 kg, and it contains two basic ingredients B_1 and B_2 . B_1 costs Rs. 5/kg and B_2 costs Rs. 8/kg. Strength considerations dictate that the brick contains not more than 4 kg of B_1 and a minimum of 2 kg of B_2 . Since the demand for the product is likely to be related to the price of the brick, find out graphically the minimum cost of the brick satisfying the above conditions.

7. Solve by graphical method the following problem.

Minimize $Z = 5x_1 + 4x_2$
 Subject to $4x_1 + x_2 \geq 40$
 $2x_1 + 3x_2 \geq 90$
 $x_1 \geq 0, x_2 \geq 0$

b) Food A contains 20 units of vitamin x and 40 units of vitamin y per gram. Food B contains 30 units of each of vitamins x and y. The daily minimum human requirements of vitamin x and y are 900 units and 1200 units respectively. How many grams of each type of food should be consumed so as to minimize the cost, if food A costs 60 paise per gram and food B 80 paise per gram.

8. A company produces two types of products say type A and type B. Product A is of superior quality and product B is of a lower quality. Respective profits for the two types of products are Rs. 40/- and 30/-. The data on the resource required, availability of resources are given below:

	Requirements	
	Product A	Product B
Raw materials (kg)	120	60
Machining time (hrs/piece)	5	8
Assembly (man-hour)	4	3

4.8 Simplex Method

Basic Properties

The simplex method is based on the following fundamental properties:

Property 1: The collection of feasible solutions constitutes a convex set.

Property 2. If a feasible solution exists, a basic feasible solution exists where the basic feasible solution corresponds to the extreme points (corner points) of the set of feasible solutions.

Property 3. There exist only a finite number of basic feasible solutions.

Property 4. If the objective function possesses a finite maximum or minimum, then at least one optimal solution is a basic feasible solution.

These properties can be easily verified for their plausibility with reference to the graphical representation. The reason for these properties can be attributed to the complete linearity of the linear programming model. We shall clarify the hypothesis of properties 2 and 4. The linear programming problem need not necessarily have any feasible solution. This will be so when the constraints have inconsistencies or contradictions.

In the above example the third constraint $x + y \leq 60$ is replaced by, say, $x + y > 100$. Then we cannot have a single solution space to offer solution space to have an infinitely high value subject to the restrictions rather than some finite number. This will be the case when in the example the second and the third constraint have been deleted. Then the solution space and the solution are unbounded. As per this model the objective function will have $Z = +\infty$ as the feasible solution. Suppose there exists a feasible solution and that the optimal value of Z is finite, properties 2 and 3 indicate that the number of basic feasible solutions is strictly positive and finite. From the property 4 we infer that only this finite number of solutions namely the basic feasible solutions or the extreme points are to be investigated to find an optimal solution. Hence even though there exists an infinite number of feasible solutions, it is enough to find the value of the objective function for the basic feasible solutions. Hence we limit to only a few of the feasible solutions. Therefore we examine the value of the objective function at each of the corner points or basic feasible solutions and select the one with the largest value of Z in a maximization problem and the smallest value of Z in a minimization problem.

If we apply the above logic to the first example the basic feasible solutions include the following with the value of Z as shown in the table below:

(x, y) (Basic feasible solution)	value of $Z = 4x + 7y$
0, 0	0
0, 30	210
30, 30	330*
40, 20	300
40, 0	160

We take the largest value of Z as the optimum denoted by $Z^* = 330$ and the values of the decision variables as $x = 30, y = 30$.

One more interesting fact can be inferred from the property 4 that an optimal solution need not be a basic feasible solution. This can take place if a number of feasible solutions yield the same maximum feasible value of Z , since the property 4 guarantees only that at least one of these will be a basic feasible solution. To illustrate, suppose that the objective function in the above example is changed to $Z = 4x + 4y$. Then not only the two basic feasible

solutions (30, 30) , (40, 20) but also all the non-basic feasible solutions that lie on the line segment between the two points, numbering to infinity, would have been optimal solutions.

4.8.1 Simplex Procedure

The simplex method is an algebraic procedure involving a well-defined iterative process, which leads progressively to an optimal solution in a few numbers of finite steps. Dantzig introduced the method in 1947 and even today this seems to be the most versatile and powerful tool to solve linear programming problems. For routine linear programming problems, computer solution packages have been developed to use in an electronic digital computer. In the next section we describe what a simplex method does and how it solves a linear programming problem.

Example

Consider $Z = 3x + 5y$

Subject to $x \leq 40, y \leq 30, x + y \leq 60, \& x, y \geq 0.$

First step in the simplex method is to convert the linear programming model involving inequalities into strict equalities, by the use of "slack variables". To illustrate the above idea, suppose we have the inequality $x \leq 40$. How can one replace this in equation by an equivalent equation? This inequality $x \leq 40$ implies the meaning that x can take a value of 40 or less. If the value of x is exactly 40, then this is the required equation. But since it also tells that x can take a value less than 40, it is necessary to add some positive value to x to make it up to 40. This additional non-negative variable is called the slack variable denoted by S_1 . We can then write

$$x + S_1 = 40$$

so that the above is an equation. This has been achieved by the addition of a slack variable S_1 to the left hand side of the in equation, which can take a value between 0 and 40 both inclusive. If $S_1 = 0$, then $x = 40$ and if $S_1 = 40$, then $x = 0$. Thus the slack variable is strictly non-negative.

So we conclude that the addition of a non-negative variable called slack variable converts the 'less than equal to' constraint into strict 'equality constraint'.

The second inequality, $y \leq 30$ can also be converted into an equation by adding another slack variable S_2 to the left hand side. Thus we have

$$y + S_2 = 30$$

Similarly the third constraint $x + y \leq 60$ is also converted with the addition of another slack variable S_3 so that we have,

$$x + y + S_3 = 60$$

Thus an equivalent model alters the original linear programming model,

$$\begin{array}{ll} \text{Maximize} & Z = 3x + 5y \\ \text{Subject to the restrictions,} & \\ & x + S_1 = 40 \quad (1) \\ & y + S_2 = 30 \quad (2) \\ & x + y + S_3 = 60 \quad (3) \\ \text{and} & x, y \geq 0 \end{array}$$

The above form of representation of a linear programming problem is much more convenient for algebraic manipulation and for identification of basic feasible solutions.

Referring to the restrictions in the above example, there are five variables x , y , S_1 , S_2 , and S_3 all of them being non-negative and their values are to be determined to find an optimal solution. We have only three equations (1), (2) and (3) involving five variables. We cannot find a solution with the set of three equations in five unknowns. We must have at least five linearly independent equations to solve for all the five variables so that they will have unique values. Almost we can solve three variables in terms of the remaining two variables.

In general, if there are m equations in n variables ($n > m$), a *basic solution* is obtained by solving m variables in terms of the remaining variables and letting $(n - m)$ variables equal to zero. This assumes that such a solution exists and is unique. A *basic feasible solution* is a basic solution where all m of these variables are non-negative. A *non-degenerate* basic solution is a basic solution where these m variables are strictly > 0 , (i.e.) positive. The m variables chosen from among n variables are called as "basic" variables or as the variables in the "basis". The remaining $(n - m)$ variables are termed as "non-basic" variables and their values are zero.

Now, considering the example above, we can choose any three variables and refer to as the basic variables and the remaining two as non-basic variables. A question may be asked at this juncture as to which three variables to choose from the five variables. This leads to a combinatorial problem of selecting any three variables from among five variables and we have 5C_3 (i.e.) 10 combinations. Ten such combinations can be listed and try with the objective function with the combination selected and we can choose the optimal solution. All of them will be basic solutions. But one or more of them may lead to the optimum objective function. But this is an exhaustive enumeration process, which is time consuming.

In the simplex method, it is customary that we select the slack variables viz. S_1 , S_2 and S_3 (in the example cited) to form the initial basic variables, letting x and y as non-basic variables. We can rewrite the above equation as

$$\begin{aligned} S_1 &= 40 - x \\ S_2 &= 30 - y \\ S_3 &= 60 - x - y \end{aligned}$$

and the non-basic variables x and y are set equal to zero. Therefore, the initial basic feasible solution is

$$\begin{aligned} x &= 0 \\ y &= 0 \\ S_1 &= 40 \\ S_2 &= 30 \\ S_3 &= 60 \end{aligned}$$

and automatically the value of $Z = 3x + 5y$ becomes 0.

Thus we have an initial solution for the linear programming problem with $Z = 0$. Since the objective function is 0 the question now are any other solution that will be better than the current one. Thus we are forced to find the next basic feasible solution, which will give more profit. This requires selection of a new basic variable to be included and a variable to leave the basis. The new basic variable to be included is called 'the entering variable' and the variable we remove from the basis is called the 'leaving variable'.

How are the leaving variable and entering variable selected?

The entering variable is chosen by examining the objective function to estimate the effect of each alternative. In our example the objective function is to maximize $Z = 3x + 5y$ and if the value of any one of the variables x and y is changed from the present value of 0, to a positive, there is an increase in the objective function (as the coefficients of x and y are positive on the right hand side). Therefore either x or y , or x and y would increase Z by entering into the basis. Now the question is which to select x or y , or both x and y . There are many alternatives. But clearly we see that the objective function will reach a greater value if we choose that variable that has more positive coefficient. In the example we have the coefficient of x as 3 and the coefficient of y as 5. Since x increases Z at the rate of 3 per unit increase in x and y increases Z at the rate of 5 per unit increase in y , y should be the entering variable, even though both are potential entering variables and the objective function is written as

$$Z - 3x - 5y = 0$$

in which case we have to choose the variable whose coefficient is more negative on the left hand side of equation.

Having decided to choose y to enter the basis, we have to select the variable leaving the basis. As we have only three equations but five unknowns, only three variables can be solved in terms of the other two.

To decide the candidate to be removed from the basis, we choose the variable whose value reaches zero first as the value of the entering variable is increased.

The equations involving the slack variables may be rewritten as

$$\begin{aligned} S_1 &= 40 - x & (1) \\ S_2 &= 30 - y & (2) \\ S_3 &= 60 - x - y & (3) \end{aligned}$$

Referring to the above equations, as the value of y is increased, S_1 will never become zero as the first equation does not involve y . This means that S_1 will not leave the basis. The second equation indicates that S_2 will be zero for the value of $y = 30$ and from the third equation we infer that S_3 will be zero for the value of $y = 60$. So among the three candidates S_1 , S_2 and S_3 , S_2 will reach zero first as the value of y is increased to 30 from zero. Therefore S_2 is chosen as the leaving variable.

Now, we have to find the values of the remaining basic variables. This is done by the use of the Gauss Jordan method of elimination in which the objective function is expressed only in terms of the non-basic variables.

This requires that each basic variable appears in exactly one equation and that this equation contains no other basic variable. Consider the original set of equations where the basic variables are indicated bold

$$\begin{aligned} Z - 3x - 5y &= 0 & (0) \\ x + S_1 &= 40 & (1) \\ y + S_2 &= 30 & (2) \\ x + y + S_3 &= 60 & (3) \end{aligned}$$

The solution set is $Z = 0$, $S_1 = 40$, $S_2 = 30$, $S_3 = 60$, $x = y = 0$.

The variable y enters the basis and S_2 leaves the basis. So the variables in the new basis are y , S_1 and S_3 . The new basic variable y has replaced S_2 as the basic variable in equation (2). Gauss elimination process requires that y must now be eliminated from the other equations in which it appears. This is achieved by adding a suitable multiple of equation (2) to the other equations. Thus, the *new* equation (0) is the old equation (0) plus five times the equation (2) and the *new* equation (3) will be obtained by multiplying the equation (2) with -1 and adding to the old equation (3) which is entirely equivalent to the first set algebraically. So the second set of equations after manipulating the first set or original set of equations is presented below with the basic variables indicated bold.

$$\begin{aligned} Z - 3x + 5S_2 &= 150 & (0) \\ x + S_1 &= 40 & (1) \\ y + S_2 &= 30 & (2) \\ x - S_2 + S_3 &= 30 & (3) \end{aligned}$$

The solution set is:

$$Z = 150, \quad S_1 = 40, \quad y = 30 \quad \text{and} \quad S_3 = 30, \quad x = S_2 = 0$$

Now we question whether the above second basic feasible solution is optimal or a still better solution is available. Can we still move up in the ladder of maximization? An answer is given by examining the objective function in the new set of equations. We are no longer using our original objective function. Examination of the

objective function row reveals that x and S_2 are the two non-basic variables and between them, if we choose x (since it has a negative coefficient) as a candidate for entering the basis, the objective function value further increases. S_2 is not a candidate to enter the basis as it has a positive coefficient. Hence we have to include x in the new basis, thus x is the next candidate to enter the basis; As x is selected to enter the basis, one of the variables in the basis viz, S_1 , y , S_3 has to leave the basis. We apply the criterion for selecting the leaving variable. As we assign the value for x in the equations (1) to (3), we observe that S_1 will be zero for $x = 40$ and that S_3 will be zero for $x = 30$. Since S_3 will reach zero earlier as we assign values of x , S_3 will be the next leaving variable from the basis. So we need to apply the elimination procedure once again to get a new solution. This means another iteration is required.

Proceeding once again with the elimination process, we get the set of equations presented below:

$$Z \qquad \qquad \qquad +2S_2 + 3S_3 \qquad = 240 \qquad (0)$$

$$\qquad \qquad \qquad +S_1 + S_2 + S_3 \qquad = 40 \qquad (1)$$

$$y \qquad \qquad +S_2 \qquad \qquad \qquad = 30 \qquad (2)$$

$$x \qquad \qquad -S_2 + S_3 \qquad \qquad = 30 \qquad (3)$$

Now a question may arise whether the above solution constitutes the best or optimal solution. Examining the objective function

$$Z + 2S_2 + 3S_3 = 240,$$

we observe that the coefficients of the non-basic variables S_2 and S_3 are positive on the left hand side and this is the indication to stop the iteration. Hence we conclude that $Z = 240$ will be the maximum value of Z and the solution set can be written as

$$Z^* = 240$$

$$x = 30$$

$$y = 30$$

$$S_1 = 40$$

$$S_2 = 0$$

$$S_3 = 0$$

4.9 Application of Simplex Algorithm

The relevant information of first example may be presented in a concise form as what we call 'Simplex table' instead of writing down the set of equations in full symbols for the variables in each of the equations. The given linear programming problem is expressed in a standard form including slack variables. Then we write the coefficients of the variables and the right hand side in the table.

The above example is presented in the following tabular form. This is the initial table.

Equation No.	Basic Variable	Coefficient of						RHS	Ratio
		Z	x	y	S_1	S_2	S_3		
0	-	1	-3	-5	0	0	0	0	-
1	S_1	0	1	0	1	0	0	40	∞
2	S_2	0	0	1	0	1	0	30	30
3	S_3	0	1	1	0	0	1	60	60

Solution:

$$Z = 0, S_1 = 40, S_2 = 30, S_3 = 60, x = y = 0$$

The basic procedure when using the simplex table is the same as before. We give below the steps of the simplex method that would be applied to prepare the next table from the initial table.

4.9.1 Step 1 (Selection of basic entering variable)

Consider the first row corresponding to the equation 0 of the table. If the problem is one to maximize the effectiveness (profit), the variable with the most negative coefficient is selected as the new entering basic variable. The column corresponding to the most negative coefficient -5 is 'y' and the same is marked as a *key column* indicating that y is the new entering basic variable.

4.9.2 Step 2 (Selection of leaving basic variable)

Now consider all the rows except the first row. Formulate the ratio in each row by taking right hand side of each row and dividing by the corresponding element of the key column. The ratios in this example are $40/0 = \infty$, $30/1 = 30$, $60/1 = 60$. Select the least *non-negative* ratio. In this example the minimum non-negative ratio corresponds to the row 2 indicating that S_2 is the leaving basic variable and this row containing S_2 as the basic variable is marked as a *key row*. The element at the intersection of key column and key row is called the key number or pivot number. In this example the key number is 1. If this is not 1, the same can be made 1 by dividing the same row suitably.

4.9.3 Step 3 (Elimination of coefficients in the key column)

Gauss Jordan elimination requires that all the elements in the key column except the key row should vanish. Suitably multiplying coefficients of the key row and adding the same to the corresponding coefficients of the other rows achieve this result.

In this example, multiply the key row by 5 and add this resulting row to the row 0. To get rid of the coefficient of y in the second row, next multiply the key row by 0 and add to the row 1 and similarly multiply the key row by -1 and add to the row 3 to eliminate the coefficient of y in the third row. So all the key column elements are thus made 0 in all the rows except the key row. The resulting table is presented. Note that y has entered the basis and S_2 has left. This is the first iteration

Iteration I: y enters the basis and S_2 leaves the basis

Eqn. No.	Basic Variable	Coefficient of						RHS	Ratio	Solution
		Z	x	y	S_1	S_2	S_3			
0	-	1	-3	0	0	5	0	150	-	Z=150
1	S_1	0	1	0	1	0	0	40	40	$S_1=40$
2	y	0	0	1	0	1	0	30	∞	y=30
3	S_3	0	1	0	0	-1	1	30	30	$S_3=30$

4.9.4 Step 4 (Further improvement of solution)

After every iteration, look at the objective function row (row 0). Scan if there is any negative coefficient among variables in this row for a maximization problem. If there is a negative coefficient, this is a clear indication that the problem has not reached the maximum value. Still there is a scope of improving the existing solution. In this example, we have the coefficient of x in the objective function row as -3 (a negative) indicating that x can be selected as the new entering basic variable. Mark this column as key column and another iteration is required. So find the ratio in each of the rows 1, 2 and 3. We have the ratios 40, ∞ and 30 as indicated in the table under the column ratio. Select the row corresponding to least non-negative value (i.e.) 30, (row 3). So S_3 is the leaving variable and this key row is marked and the same procedure of eliminating the coefficients of x in the key column is performed by multiplying the key row by 3, -1 and 0 and adding to the row 0, 1 and 2 respectively. The result is presented in the table below.

4.9.5 Step 5 (Stopping rule)

The row 0 has all coefficients of the variables as non-negative. If there is no negative coefficient in this row, this is an indication that the problem has reached the maximum value and this is the optimal solution to the linear programming problem.

Note: If the problem is one of minimization subject to constraints of \leq sign, the criterion for selecting the entering variable is to pick the variable in the objective row with the most positive coefficient. If all of them are negative or 0, this suggests that the present solution is the optimum.

4.9.6 Exercise

1. A manufacturer has two products P_1 and P_2 both of which are produced in two steps by machines M_1 and M_2 . The process times per hundred for the products on the machines are:-

Products	M_1	M_2	Contribution (per 100 units)
P_1	4	5	Rs. 10
P_2	5	2	Rs. 5
Available hrs	100	80	

The manufacturer is in a market upswing and can sell as much as he can produce of both products. Formulate the mathematical model and determine optimum product mix using simplex method.

2. The ABC company, a manufacturer of test equipment has three major departments for its manufacture of X-10 model and X-20 model. Monthly capacities are given as follows:-

	Time required X-10 Model	per unit X-20 Model	Hours available this month
Main Frame Department	4.0	2.0	1,600
Electrical Wiring Department	2.5	1.0	1,200
Assembly Department	4.5	1.5	1,600

The contribution of the X-10 model is Rs. 40/- each and the contribution of the X-20 model is Rs. 10/- each. Assuming that the company can sell any quantity of either product due to favorable conditions, find:

- the optimal output for both models with the help of simplex method
- the highest possible contribution for this month.
- the slack time in the three departments.

3. A manager produces three items A, B and C. He has the possibility of applying two strategies - produce all the three items or any two of them. Products A and C pass through shops I and II, whereas B is further processed in shop III. Each shop has limited available hours. Hours available in shops I, II and III are 162 hours, 189 hours and 5 hours respectively. Profit per unit from A, B and C is Rs. 27/-, Rs. 29/- and Rs. 25/- respectively. The following table gives the processing time of different items in different shops.

Items

Shops	A	B	C
I	27	12	12
II	27	15	25
III	0	3	0

Find the optimum production of A, B and C so as to maximize profit.

4. The ABC manufacturing company can make two products P_1 and P_2 . Each of the products requires time on a cutting machine and a finishing machine.

	Product	
	P_1	P_2
Cutting hours (per unit)	2	1
Finishing hours (per unit)	3	3
Profit per unit	Rs. 6	Rs. 4
Maximum sales (unit per week)	-	200

The number of cutting hours available per week is 390 and number of finishing hours available per week is 810. How much should be produced of each product in order to achieve maximum profit for the company?

5. A manufacturer can produce three products A , B and C which pass through different machines M_1 , M_2 and M_3 . Available machines for each product and the requirement of machine time for each product is given in the matrix below.

Machine time in hours	Products			Available time in hours
	A	B	C	
M_1	1	2	2	1,900
M_2	3	2	4	2,100
M_3	3	2	-	1,500

If the profit of each unit of A , B and C is respectively Rs. 5, Rs. 4 and Rs. 6, find how many units of each product should be produced so that the profit will be maximum.

6. A firm produces 3 products A , B and C using same type of materials L , M , and N . The specific consumption of each material for unit production is given in the table. The profits of A , B and C are respectively Rs. 70, Rs. 50 and Rs. 60.

Material	Quantity required per unit of production			Available Material
	L	M	N	
L	2	1	3	80
M	4	4	1	240
N	3	4	2	160

- (a) Find the suitable production programme so as to maximize the profit.
 (b) What type of surplus material would be available? Can you utilize materials?
 (c) Find the production pattern (revised) and profit theorem.
7. A material manufacturing firm has discontinued production of a certain unprofitable product line. This created considerable excess production capacity. Management is considering devoting this excess capacity to one or more of three products; calling them products 1, 2 and 3. The available capacity on the machines which limit output is summarized in the following table.

Machine type	Available time (in machine-hour per week)
	Milling machine
Lathe	150
Grinder	50

The number of machine-hours required for each unit of the respective products is given below.

Machine type	Productivity (in machine hours per unit)		
	Product 1	Product 2	Product 3
Milling machine	8	2	3
Lathe	4	3	0
Grinder	2	-	1

The unit profit would be Rs. 20, Rs. 6 and Rs. 8 respectively for products 1, 2 and 3. Find how much of each product the firm should produce in order to maximize profit.

8. A factory produces three products, which are processed through three different stages. The time required to manufacture one unit of each of the three products and the daily capacity of the stages are given in the following table.

Stage	Time per unit in minutes			Stage capacity (minutes)
	Product 1	Product 2	Product 3	
1	1	2	1	430
2	3	-	2	460
3	1	4	-	420
Profit per unit (Rs.)	3	2	5	

- Set the data in a simplex table.
- Find the table of optimum solution.
- State from the table-maximum profit, production pattern and surplus capacity of any stage.
- What is the meaning of the shadow price? Where is it shown in the table? Explain it in respect of resources of stages having shadow price.
- How many units of other resources will be required to completely utilize the surplus resource?

9. Solve the following problem using simplex method:

Maximize $x_0 = 2x_1 + 3x_2 + 4x_3$

Subject to

$$2x_1 + x_2 + 2x_3 \leq 50$$

$$x_1 + 3x_2 + x_3 \leq 25$$

$$x_1 + 2x_2 + x_3 \leq 26$$

$$x_1, x_2, x_3 \geq 0$$

10. A furniture company can produce four types of chairs. Each chair is first made in the carpentry shop and then varnished, waxed and polished in the finishing shop. Manhours required in each shop are:

	Chair type	1	2	3	4
Carpentry shop		4	9	7	10
Finishing shop		1	1	3	40
Contribution per chair-Rs.		12	20	18	40

Total number of man-hours available per month in carpentry and finishing shops are 6000 and 4000 respectively. Assuming abundant the number of chairs of different type produced so that profit is maximized using the simplex method.

11. A stereo equipment manufacturer can produce two models A and B of 40 and 80 watts total music power each. Each model passes through three different manufacturing divisions 1, 2 and 3 where model A takes 4, 2.5 and 4.5 hrs each and model B takes 2, 1 and 1.5 hrs each. The three divisions have a maximum of 1600, 1200 and 1600 hours every month respectively. Model A gives a contribution of Rs. 400 each and B gives Rs. 100 each. Assuming abundant product demand, find out the optimum product mix and the maximum contribution through simplex method.
12. A company produces three products P , Q and R from three raw materials A , B and C . One unit of product P requires 2 units of A and 3 units B . A unit of product Q requires 2 units of B and 5 units of C and one unit of product R requires 3 units of A , 2 units of B and 4 units of C . The company has 8 units of material A , 10 units of material B and 15 units of material C available to it. Profits per unit of products P , Q and R are Rs. 3, Rs. 5 and Rs. 4 respectively.
- a) Formulate the problem mathematically.
b) How many units of each product should be produced to maximize profit?
13. A pharmaceutical company has 100 kg of A , 180 kg of B and 120 kg of C available per month. They can use these materials to make three products namely 5-10-5, 20-5-10, where the numbers in each case represent the percentage by weight of A , B and C respectively in each of the product. The cost of the raw materials are given below.

Ingredient	A	B	C	Inert Ingredient
Cost per Kg (Rs.)	80	20	50	20

Selling price of these products are Rs. 40.5, Rs. 43 and Rs. 45/kg respectively. There is a capacity restriction that the product 5-10-5 cannot be produced more than 30 kg per month. Determine how much of each product they should produce to maximize their monthly profit.

14. Consider the following linear programming problem:

Maximize $x_0 = 3x_1 + 2x_2 + 5x_3$

Subject to

$$\begin{aligned}x_1 + 2x_2 + 2x_3 &\leq 8 \\3x_1 + 2x_2 + 6x_3 &\leq 12 \\2x_1 + 3x_2 + 4x_3 &\leq 12 \\x_1, x_2, x_3 &\geq 0\end{aligned}$$

- (i) Solve this problem by simplex method.
 (ii) Does this problem have an alternative optimal solution?
 (iii) The validity of one of the steps in simplex method becomes questionable as you work out this problem. What is this step?

15. An aviation fuel manufacturer sells two types of fuel, *A* and *B*. Type *A* fuel is 25 per cent grade I petrol, 25 per cent grade II petrol and 50 per cent grade III petrol. Type *B* fuel is 50 per cent grade II petrol and 50 per cent grade III petrol. Available for production are 2000 liters/hour of grade I and 800 liters/hour of grade II and III. The cost of petrol is Rs. 3 per litre for grade I, Rs. 6 per litre for grade II and Rs. 5 per litre for grade III. Type *A* can be sold for Rs. 7.5 per litre and type *B* for Rs. 9.00 per litre. How much of each fuel should be made?

16. A manufacturer uses three raw products *a*, *b*, *c* priced at 30, 50 and 120 rupees per kg respectively. He can make three different products *A*, *B* and *C*, which can be sold at 90, 100 and 120 rupees per kg respectively. The raw products can be obtained only in limited quantities, namely 20, 15 and 10 kg per day. Given 2 kg of *a* plus 1 kg of *b* plus 1 kg *c* will yield 4 kg of *A*, 3 kg of *a* plus 2 kg of *b* plus 2 kg of *c* will yield 7 kg of *B*, 2 kg of *b* plus 1 kg of *c* will yield 3 kg of *C*.

Make a production plan, assuming the order and cost are not influenced by the choice among the alternatives. Solve the problem by simplex method.

4.10 Artificial Variable Technique

If slack variables do not provide an initial basic feasible solution then the question may arise as to how to start the initial table of simplex method and proceed. This is the case when the slack variables have negative values.

For example, let us consider a constraint $2x + 3y \geq 15$

The method of converting this inequality (with greater than equal to) into an equation, is to *subtract* a slack variable so that we have $2x + 3y - S = 15$

Now if x and y are non-basic variables in the problem, then S is taken as the starting basic variable. But the value of $S = -15$ which is infeasible. We cannot proceed with the further iteration of the simplex method with infeasible basic solution.

So to obtain a starting solution, we adopt the 'artificial variable' technique. Two methods are available using the artificial variables. They are,

- (1) The "Big M technique" or the Charnes method of penalty.
- (2) The two phase technique.

4.10.1 The 'Big M' Technique

If some of the constraints in the linear programming problems are of the type (\geq) or ($=$), we have to use the M technique for maximization as well as minimization of an objective function. The various steps of the M technique are given below.

STEP 1 Express the given linear programming problem in the equation form by bringing all the terms in the objective function to the left hand side and the constraints are also expressed in the equation form by including slack variables (Add slack variable for constraint of the type \leq and subtract slack variable for constraint of the type \geq).

Now obtain a basic solution for the problem, which will be an infeasible one as the basic variable is negative in the cases where the constraints are of the type (\geq).

STEP 2 To get a starting basic feasible solution, add non-negative variables to the left hand side of each of the equations corresponding to the constraints of the types (\geq) and ($=$). These variables are called artificial variables. Thus we change the constraint to get a basic solution. This violates the corresponding constraints. This is only for the starting purpose. But in the final solution (if it exists) if the artificial variables will become non-basic, (their values will be zero) then we are coming back to the original constraints. This method or driving the artificial variables out of the basis is called the *Big M* technique. This result is achieved by assigning a very large (big) per unit penalty to these variables in the objective function. Such a penalty will be a $-M$ for maximization and a $+M$ for minimization problems, on the right hand side, the value of M being strictly positive. By attaching these per unit penalties to the artificial variables we ensure that they will never become the candidates for entering variables once they are driven out.

STEP 3 For the starting basic solution; use the artificial variables in the basis. Now the starting table in the simplex procedure should not contain the terms involving the basic variables, (one of the conditions to be satisfied by the simplex method). But we will have the terms like $+MA$ or $-MA$ in a maximization or minimization problem respectively in the left hand side of the objective row. In other words, the objective function must be expressed in terms of non-basic variables only. This leads us to have the coefficients of the artificial variables (starting basic variables) equal to zero in objective row. This result is obtained by adding suitable multiples of the constraint equations involving artificial variables to the objective row.

STEP 4 Proceed with the regular steps of the simplex method. If the artificial variables leave the basis in the final solution, then we come back to the original problem. But if any or all of the artificial variables do not leave the basis in the final solution, then this indicates that the problem does not have a solution.

Example

Consider the problem Maximize $Z = 2x + 5y$

Subject to $x \leq 40,$ $y \leq 30,$ $x + y \geq 60,$ $x, y \geq 0$

Solution

STEP 1 Bring the problem to the standard form by including slack variables.

$$\begin{array}{rcl} Z - 2x - 5y & & = 0 \\ x & + S_1 & = 40 \\ y & + S_2 & = 30 \\ x + y & & + S_3 = 60 \end{array}$$

Solution at this stage is

$$\left. \begin{array}{l} Z = 0 \\ S_1 = 40 \\ S_2 = 30 \\ S_3 = -60 \end{array} \right\} \text{Basic variables}$$

$$\left. \begin{array}{l} x = 0 \\ y = 0 \end{array} \right\} \text{Non-basic variables}$$

STEP 2 Since $S_3 = -60$ and as such is infeasible; add an artificial variable A to get an initial basic solution. Then we have the third constraint equation changed to $x + y - S_3 + A = 60$

STEP 3 Modify the objective function by including a very large per unit penalty M . Thus for maximization problem we add $-MA$ to *RHS* of the objective function which will be

$$Z - 2x - 5y = -MA$$

or

$$Z - 2x - 5y + MA = 0$$

with the constraints

$$\begin{array}{rcl} x & + S_1 & = 40 \\ y & + S_2 & = 30 \\ x + y & - S_3 + A & = 60 \end{array}$$

Now the required condition is that the objective function must be expressed in terms of the *non-basic variables* only. Or the coefficients of the basic variables in the objective function must be zero. In the problem, the starting basic variables are S_1, S_2 and A . The coefficients of A must be made 0 in the objective function, a result which is obtained by multiplying the corresponding constraint equation including the artificial variable by $-M$ and adding to the objective function.

Now Z equation = old Z equation + $(-M)$ A equation

Thus we have the revised objective function as,

$$(Z - 2x - 5y + MA = 0) + (-M)(x + y - S_3 + A = 60)$$

$$(i.e.) \quad Z - 2x - Mx - 5y - My + MS_3 = -60M$$

$$(i.e.) \quad Z + (-2 - M)x + (-5 - M)y + MS_3 = -60M$$

Now the initial table in simplex method is presented below and further iterations are carried out to obtain a final feasible solution.

Starting Table:

Eqn. No.	Basic Variable	Coefficient of							RHS	Ratio
		Z	x	y	S_1	S_2	S_3	A		
0	-	1	-2-M	-5-M	0	0	M	0	-60M	
1	S_1	0	1	0	1	0	0	0	40	∞
2	S_2	0	0	1	0	1	0	0	30	30
3	A	0	1	1	0	0	-1	1	60	60

First Iteration: y enters and S_2 leaves the basis.

Eqn. No.	Basic Variable	Coefficient of							RHS	Ratio
		Z	x	y	S_1	S_2	S_3	A		
0	-	1	-2-M	0	0	5+M	M	0	150-30M	
1	S_1	0	1	0	1	0	0	0	40	40
2	y	0	0	1	0	1	0	0	30	∞
3	A	0	1	0	0	-1	-1	1	30	30

Second Iteration: x enters and A leaves the basis.

Eqn. No.	Basic Variable	Coefficient of							RHS	Ratio
		Z	x	y	S_1	S_2	S_3	A		
0	-	1	0	0	0	7	-2	2+M	210	
1	S_1	0	0	0	1	1	1	-1	10	10
2	y	0	0	1	0	1	0	0	30	∞
3	x	0	1	0	0	-1	-1	1	30	-30

Third Iteration: S_3 enters and S_1 leaves the basis.

Eqn. No.	Basic Variable	Coefficient of							RHS
		Z	x	y	S_1	S_2	S_3	A	
0	-	1	0	0	2	9	0	M	230*
1	S_3	0	0	0	1	1	1	-1	10
2	y	0	0	1	0	1	0	0	30
3	x	0	1	0	1	0	0	0	40

From the above table, we see that there is no negative coefficient in the objective row. This indicates that we have reached the optimal solution to the problem.

Another fact which can be noticed that the artificial variable A has left the basis.

Hence we have the original constraint and the original objective function preserved.

The optimal solution

$$\begin{aligned} Z^* &= 230 \\ x &= 40 \\ y &= 30 \\ S_3 &= 10 \\ \text{and } S_1 = S_2 = A &= 0 \end{aligned}$$

Example Using surplus and artificial variable, solve the following:

$$\begin{aligned} \text{Minimize } & Z = 5x_1 + 6x_2 \\ \text{Subject to } & 2x_1 + 5x_2 \geq 1500 \\ & 3x_1 + x_2 \geq 1200 \\ & x_1, x_2 \geq 0 \end{aligned}$$

Solution

Introducing slack (surplus) variables S_1 and S_2 and artificial variables A_1 and A_2 to the two constraints the problem becomes,

$$\begin{aligned} \text{Minimize } & Z = 5x_1 + 6x_2 + MA_1 + MA_2 \\ \text{Subject to } & 2x_1 + 5x_2 - S_1 + A_1 = 1500 \\ & 3x_1 + x_2 - S_2 + A_2 = 1200 \end{aligned}$$

Since the objective function should not involve coefficient of basic variables A_1 and A_2 , we multiply the constraint equation with M and add to the objective function. The revised objective function will be

$$Z - 5x_1 + 5Mx_1 - 6x_2 + 6Mx_2 - MS_1 - MS_2 = 2700M$$

We prepare the simplex table as follows:

Initial table:

Eqn. No.	Basic variable	Coefficient of							RHS	Ratio
		Z	x_1	x_2	S_1	S_2	A_1	A_2		
0	-	1	$5M-5$	$6M-6$	$-M$	$-M$	0	0	$2700M$	
1	A_1	0	2	5	-1	0	1	0	1500	300
2	A_2	0	3	1	0	-1	0	1	1200	1200

Divide the equation 1 by 5 throughout.

Eqn. No.	Basic variable	Coefficient of							RHS	Ratio
		Z	x_1	x_2	S_1	S_2	A_1	A_2		

0	-	1	5M-5	6M-6	-M	-M	0	0	2700M	
1	A ₁	0	2/5	1	-1/5	0	1/5	0	300	300
2	A ₂	0	3	1	0	-1	0	1	1200	1200

First Iteration: x_2 enters and A_1 leaves the basis.

Eqn. No.	Basic variable	Coefficient of							RHS	Ratio
		Z	x_1	x_2	S_1	S_2	A_1	A_2		
0	-	1	13M-5	0	M-1	-M	-6M+6	0	900M+1800	
1	x_1	0	2/5	1	-1/5	0	1/5	0	300	750
2	A ₂	0	13/5	-1	1/5	-1	-1/5	1	900	346

Second Iteration: x_1 enters and A_2 leaves the basis.

Multiply Eqn. 2 by 5/13 to make the key number 1. Then we have

Eqn. No.	Basic variable	Coefficient of							RHS	Ratio
		Z	x_1	x_2	S_1	S_2	A_1	A_2		
0	-	1	13M-13	0	M-1	-M	-6M+6	0	900M+1800	
1	x_2	0	2/5	1	-1/5	0	1/5	0	300	750
2	A ₂	0	1	0	1/13	-5/13	-1/13	5/13	346	346

Eqn. No.	Basic variable	Coefficient of							RHS
		Z	x_1	x_2	S_1	S_2	A_1	A_2	
0	-	1	0	0	0	-1	-M+1	-M+1	2700
1	x_2	0	0	1	-15/65	2/13	3/13	-2/13	2100/13
2	x_1	0	1	0	1/13	-5/13	-1/13	5/13	4500/13

Since the equation 0 does not contain positive coefficient of the variables, the solution found is the optimum.

Solution: $Z^* = 2700$, $x_1 = 4500 / 13$, $x_2 = 2100 / 13$

Example

Minimize $Z = 4x_1 + x_2$

Subject to $3x_1 + 4x_2 \geq 20$
 $-x_1 - 5x_2 \leq -15$
 $x_1, x_2 \geq 0$

Solution:

The second constraint can be changed into inequality of the type by multiplying by -1 throughout. Then introduce slack variable and artificial variable to the two constraints. The equations are transformed into

$$\begin{aligned} Z - 4x_1 - x_2 - MA_1 - MA_2 &= 0 \\ 3x_1 + 4x_2 - S_1 + A_1 &= 20 \\ x_1 + 5x_2 - S_2 + A_2 &= 15 \end{aligned}$$

The objective function should not involve the coefficients of basic variables A_1 and A_2 . So, multiply the constraint equation by M and add to the objective equation. Then we get the following equations.

$$\begin{aligned} Z - 4x_1 + 4Mx_1 - x_2 + 9Mx_2 - MS_1 - MS_2 &= 35M \\ 3x_1 + 4x_2 - S_1 + A_1 &= 20 \\ x_1 + 5x_2 - S_2 + A_2 &= 15 \end{aligned}$$

The above equations can be conveniently set down in the Simplex table as shown below.

Initial table:

Eqn. No.	Basic variable	Coefficient of							RHS	Ratio
		Z	x_1	x_2	S_1	S_2	A_1	A_2		
0	-	1	$4M-4$	$9M-1$	$-M$	$-M$	0	0	$35M$	
1	A_1	0	3	4	-1	0	1	0	20	5
2	A_2	0	1	5	0	-1	0	1	15	3

Divide equation 2 by 5 to make the key No. 1. Thus we have

Eqn. No.	Basic variable	Coefficient of							RHS	Ratio
		Z	x_1	x_2	S_1	S_2	A_1	A_2		
0	-	1	$4M-4$	$9M-1$	$-M$	$-M$	0	0	$35M$	
1	A_1	0	3	4	-1	0	1	0	20	5
2	A_2	0	1/5	1	0	-1/5	0	1/5	3	3

First Iteration: x_2 enters and A_2 leaves the basis.

Eqn. No.	Basic variable	Coefficient of							RHS	Ratio
		Z	x_1	x_2	S_1	S_2	A_1	A_2		
0	-	1	$11M-19$ 5	0	-M	$4M-$ 1 5	0	- $9M+1$ 5	$8M+3$	
1	A_1	0	$11/5$	0	-1	$4/5$	0	$-4/5$	8	$40/11$
2	2	0	$1/5$	1	0	$-1/5$	0	$1/5$	3	15

Multiply the equation 1 by $5/11$ to make the key No. 1 and the resulting table is given below:

Eqn. No.	Basic variable	Coefficient of							RHS	Ratio
		Z	x_1	x_2	S_1	S_2	A_1	A_2		
0	-	1	$11M-$ 1 5	0	-M	$-M-$ 1 5	0	- $9M+1$ 5	$8M+3$	$185/11$
1	A_1	0	1	0	$-$ $5/11$	$4/11$	0	$-4/11$	$40/11$	$40/11$
2	x_2	0	$1/5$	1	0	$-1/5$	0	$1/5$	3	$25/11$

Second Iteration: x_1 enters and A_1 leaves the basis.

Eqn. No.	Basic variable	Coefficient of							Ratio
		Z	x_1	x_2	S_1	S_2	A_1	A_2	
0	-	1	0	0	$-$ $19/11$	$-$ $3/11$	0	- $56M+14$ 25	$185/11$
1	x_1	0	1	0	$-5/11$	$4/11$	0	$-4/11$	$40/11$
2	x_2	0	0	1	$1/11$	$-$ $3/11$	0	$3/11$	$25/11$

Optimum solution:

$$Z^* = 185/11$$

$$x_1 = 40/11$$

$$x_2 = 25/11$$

4.10.2 The Two Phase Method

A difficulty is being encountered in the use of M technique in that there is a possible computational error that could result from giving a very large value of M . By this the objective coefficients of the variables x and y are now too small compared with the large numbers created by the multiples of M . The solution may become insensitive to the relative value of the original coefficients of the decision variables x and y due to the round off error which is inherent in any digital computer. The result could be that both may have equal coefficients in the objective function. To overcome this difficulty another method namely two phase method is presented below. This method involves two phases which are:

Phase I: Replace the original objective problem by the sum of the artificial variables to formulate a new problem. Then this new objective function is then *minimized* subject to the constraints of the original problem. If the problem has a feasible solution, the minimum value of the objective function will be zero which shows that all the artificial variables are zero. Then proceed to phase II. Otherwise, if the minimum value is greater than zero, we conclude that the problem has *no feasible solution*.

Phase II: Use the optimum basic solution of phase I as a starting solution for the original problem. Now the original objective function has to be expressed in terms of the non-basic variables only. This can be achieved by adding suitable multiples of the constraint equations involving artificial variables.

Example

Consider the problem

$$\begin{aligned} \text{Maximize} \quad & Z = 2x + 5y \\ \text{Subject to} \quad & x \leq 40 \\ & y \leq 30 \\ & x + y \geq 60 \\ & x, y \geq 0 \end{aligned}$$

Solution:

We try to solve this problem by the two-phase method.

Introduce slack variables S_1 and S_2 for the first two constraints respectively. Subtract a slack variable S_3 and add an artificial variable A for the third constraint so that the third constraint is changed into $x + y - S_3 + A = 60$. In this problem we have the new objective function expressed as minimization of the sum of artificial variables. We have only one artificial variable.

Phase I

$$\begin{aligned} \text{Minimize} \quad & Z = A \quad (0) \\ \text{Subject to} \quad & x + S_1 = 40 \quad (1) \\ & y + S_2 = 30 \quad (2) \\ & x + y - S_3 + A = 60 \quad (3) \end{aligned}$$

Note that the objective function is always of the minimization irrespective of whether the original problem is maximization or minimization of the objective function.

We prepare the initial table as follows:

Eqn. No.	Basic variable	Coefficient of							RHS
		Z	x	y	S_1	S_2	S_3	A	
0	-	1	0	0	0	0	0	-1	0
1	S_1	0	1	0	1	0	0	0	40
2	S_2	0	0	1	0	1	0	0	30
3	A	0	1	1	0	0	-1	1	60

In the above table the objective function has the coefficient of the basic variable A . To eliminate the same, we multiply the equation 3 involving the basic variable A by 1 and add to objective row. Hence the revised table is shown below.

Eqn. No.	Basic variable	Coefficient of							RHS	Ratio
		Z	x	y	S_1	S_2	S_3	A		
0	-	1	1	1	0	0	-1	0	60	
1	S_1	0	1	0	1	0	0	0	40	40
2	S_2	0	0	1	0	1	0	0	30	∞
3	A	0	1	1	0	0	-1	1	60	60

Solution:

$$Z = 60, S_1 = 40, S_2 = 30, A = 60, x = y = S_3 = 0$$

First Iteration:

x or y can enter the basis as they have the same positive coefficients. Choose any one, say x , and hence S_1 leaves the basis.

Eqn. No.	Basic variable	Coefficient of							RHS	Ratio
		Z	x	y	S_1	S_2	S_3	A		
0	-	1	0	1	-1	0	-1	0	20	
1	x	0	1	0	1	0	0	0	40	∞
2	S_2	0	0	1	0	1	0	0	30	30
3	A	0	1	1	-1	0	-1	1	20	20

Second Iteration:

y enters and A leaves the basis.

Eqn. No.	Basic variable	Coefficient of							RHS
		Z	x	y	S_1	S_2	S_3	A	
0	-	1	0	0	0	0	0	-1	0
1	x	0	1	0	1	0	0	0	40
2	S_2	0	0	0	1	1	1	-1	10
3	y	0	1	1	-1	0	-1	1	20

From the above table we see that the objective function $Z = 0$ and A has left the basis. Hence A becomes a non-basic variable. This is the indication that the problem has a feasible solution and we can proceed to phase II, which is explained below.

Phase II: In the phase II, a table is prepared with the objective function and the set of constraints tabulated in the final table of Phase I omitting the column of the artificial variable, as it is non-basic. In preparing the table the objective function has to be expressed in terms of the non-basic variables only. In other words, the coefficients of the basic variables must be zero.

Eqn. No.	Basic variable	Coefficient of						RHS
		Z	x	y	S_1	S_2	S_3	
0	-	1	-2	-5	0	0	0	0
1	x	0	1	0	1	0	0	40
2	S_2	0	0	0	1	1	1	10
3	y	0	0	1	-1	0	-1	20

In the above table, x and y are basic variables and their coefficients are -2 and -5 respectively. Hence the objective function must be rearranged to make the coefficients of x and y as 0. This is obtained by multiplying the equation (1) by 2 and the equation (3) by 5 and adding this to the objective row. We have the following starting table with the revised objective function.

Eqn. No.	Basic variable	Coefficient of						RHS	Ratio
		Z	x	y	S_1	S_2	S_3		
0	-	1	0	0	-3	0	-5	180	
1	x	0	1	0	1	0	0	40	∞
2	S_2	0	0	0	1	1	1	10	10
3	y	0	1	1	-1	0	-1	20	-20

The original problem is one of maximization and hence in the first iteration S_3 enters and S_2 leaves the basis.

First Iteration:

Eqn. No.	Basic variable	Coefficient of						RHS
		Z	x	y	S_1	S_2	S_3	
0	-	1	0	0	2	5	0	230*
1	x	0	1	0	1	0	0	40
2	S_3	0	0	0	1	1	1	10
3	y	0	0	1	0	1	0	30

We get the optimum value of Z in the above table as no negative coefficient is present in the objective function row.

Solution:

$$Z = 230, x = 40, y = 30, S_3 = 10, S_1 = S_2 = 0.$$

4.10.3 Exerice

- An animal feed manufacturer has to produce 200 kg of a feed mixture consisting of two ingredients x_1 and x_2 . x_1 costs Rs. 6 per kg and x_2 costs Rs. 16 per kg. Not more than 80 kg of x_1 can be used and at least 60 kg of x_2 must be used. Using simplex method, find how much of each ingredient should be used in the mix if the company wants to minimize cost. Also determine the cost of the optimum mix.
- A marketing manager wishes to allocate his annual advertising budget of Rs. 20000. in two media vehicles A and B . The unit of a message in media A is Rs. 1000 and that of B is Rs. 1500. Media A is a monthly magazine and not more than one insertion is desired in one issue. At least 5 messages should appear in media B . The expected effective audience for unit messages in the media A is 40000 and for media B is 55000.

- Develop a mathematical model.
- Solve it for maximizing the total effective audience.

- A pension fund manager is considering investing in two shares A and B . It is estimated that,

- Share A will earn a dividend of 12% per annum and share B 4% per annum.
- Growth in the market value in one year of share A will be 10 paise per Re. 1 invested and in B 40 paise per Re. 1 invested.

He requires investing minimum total sum which will give

* Dividend income of at least Rs. 600 per annum and

*growth in one year of atleast Rs. 1000 on the initial investment.

Your are required to

- (i) State the mathematical formulation of the problem.
- (ii) Compute the minimum sum to be invested to meet the manager's objective by using simplex method.

4. A company possesses two manufacturing plants each of which can produce three products x , y , z from a common raw material. However the proportions in which the products are produced are different in each plant and so are the plant's operating costs per hour. Data on production per hour and costs are given below together with current orders in hand for each product.

	x	Product y	z	Operating cost/hr (Rs.)
Plant A	2	4	3	9
Plant B	4	3	2	10
Orders on hand	50	24	60	

You are required to use the simplex method to find the number of production hours needed to fulfill the order on hand at minimum cost.

5. Maximize $x_0 = 2x_1 + x_2 + x_3$
Subject to

$$2x_1 + 3x_2 - x_3 \leq 9$$

$$2x_2 + x_3 \geq 4$$

$$x_1 + x_3 = 6$$

$$x_1, x_2, x_3 \geq 0$$

6. Minimize $Z = 3x_1 + 2.5x_2$
Subject to

$$2x_1 + 4x_2 \geq 40$$

$$3x_1 + 2x_2 \geq 50$$

$$x_1, x_2 \geq 0$$

7. The following table gives the protein, fats and carbohydrates available in 50 grams of food items F_1, F_2, F_3 and F_4 .

Food items	Protein (gms)	Fats (gms)	Carbohydrate (gms)
F_1	2.4	0.3	15.8
F_2	2.3	9.4	0.9
F_3	8.4	2.1	0.0
F_4	1.6	3.7	18.0

The price of 50 grams of each of the four items is as follows:

Item	F_1	F_2	F_3	F_4
Price in paise	5	12	20	20

The hospital has recommended that it is necessary to consume atleast 75 grams of protein 90 grams of fat and 300 grams of carbohydrate.

Solve the problem to find the minimum food bill.

8. Solve using the two-phase technique.

$$\begin{array}{ll} \text{Maximize} & Z = x_1 + 2x_2 + 3x_3 \\ \text{Subject to} & x_1 + 2x_2 + 3x_3 = 15 \\ & 2x_1 + x_2 + 5x_3 = 20 \\ & x_1 + 2x_2 + x_3 + x_4 = 10 \\ & x_1, x_2, x_3, x_4 \geq 0 \end{array}$$

9. Solve the problem by two-phase method.

$$\begin{array}{ll} \text{Maximize} & Z = x_1 + x_2 \\ \text{Subject to} & 3x_1 + 2x_2 \leq 20 \\ & 2x_1 + 3x_2 \leq 20 \\ & x_1 + 2x_2 \geq 2 \\ & x_1, x_2 \geq 0 \end{array}$$

4.11 Variants of Simplex Method

In this section we present certain complications encountered in the application of the simplex method and how they are resolved. These are called the variants of simplex method. We can illustrate the typical cases through numerical examples. The following variants are being considered.

1. Minimization
2. Inequality in the wrong direction
3. Degeneracy
4. Unbounded solution
5. Multiple solutions
6. Non-existing feasible solution
7. Unrestricted variables

4.11.1 Minimization

Sometimes we come across problems in which the objective function has to be minimized instead of maximizing. This situation can be tackled easily in either of the two ways. One is to make the following minor changes in the simplex method. The new entering basic variable should be the non-basic variable that would decrease rather than increase the value of Z at the fastest rate when this variable is increased. Similarly the test for the fastest rate when this variable is increased. Similarly the test for optimality should be whether Z can increase. Similarly the test for optimality should be whether Z can be decreased rather than increased by increasing any non-basic variable.

The second method is to change the problem into an equivalent problem involving maximization and proceed with the steps of the regular simplex method. The change is effected by maximizing the negative of the original objective function. Minimizing any function $f(x_1, x_2, x_3, \dots, x_n)$ subject to set of constraints is completely equivalent to maximizing $-f(x_1, x_2, \dots, x_n)$ subject to the same set of constraints. For example if we want to *minimize* a function $Z = 5x_1 + 7x_2 - 8x_3$, it is equivalent to *maximizing* a function $Z = -5x_1 - 7x_2 + 8x_3$.

4.11.2 Inequality in the wrong direction.

The sign or direction of inequality can easily be reversed when both sides are multiplied by -1. Therefore, if the constraint has inequality of the type (\geq), the same can be converted into the desired inequality of the type (\leq) by multiplying both sides by -1. To illustrate consider the inequality $2x + 5y \geq 18$. This is equivalent to $-2x - 5y \leq -18$. But this may lead to negative value in the right side, which makes the solution infeasible, and we may have to adopt big M technique or two-phase technique to find a feasible optimal solution.

4.11.3 Tie for the Leaving Basic Variable (Degeneracy).

The question may arise as to which of the basic variable to be selected to leave the basis when many basic variables reach zero (as indicated by equal values in the ratio column) as the entering basic variable is being changed. Thus there is a tie between or among the leaving basic variables. Of course the tie can be broken *arbitrarily*. This leads, in the next iteration, the *basic* variables to take value zero, in which case the solution is said to *degenerate*. There is no assurance that the value of the objective function will improve (Since the new solutions may remain degenerate).

Consider the following example:

Example

$$\begin{aligned} \text{Maximize} \quad & Z = 2x + 5y \\ \text{Subject to} \quad & x \leq 40 \\ & y \leq 30 \\ & x + y \leq 30 \\ & x, y \geq 0 \end{aligned}$$

Introducing slack variables, the problem is expressed in the standard form.

$$\begin{aligned} Z - 2x - 5y &= 0 & (1) \\ x + S_1 &= 40 & (2) \\ y + S_2 &= 30 & (3) \\ x + y + S_3 &= 30 & (4) \end{aligned}$$

Starting table

Eqn. No.	Basic Variable	Coefficient of						RHS	Ratio
		Z	x	y	S_1	S_2	S_3		
0	-	1	-2	-5	0	0	0	0	
1	S_1	0	1	0	1	0	0	40	∞
2	S_2	0	0	1	0	1	0	30	30
3	S_3	0	1	1	0	0	1	30	30

There is a tie between S_2 and S_3 as to which to be selected as leaving the basis. Select arbitrarily S_3 as the leaving basic variable.

First Iteration: S_3 leaves the basis and y enters.

Eqn. No.	Basic Variable	Coefficient of						RHS
		Z	x	y	S_1	S_2	S_3	
0	-	1	3	0	0	0	5	150
1	S_1	0	1	0	1	0	0	40
2	S_2	0	-1	0	0	1	-1	0
3	y	0	1	1	0	0	1	30

The optimal solution is $Z^* = 150, S_1 = 40, S_2 = 0, y = 30$

Note: One of the basic variables S_2 in the final table of the simplex method has a value equal to zero leading to a degenerate solution.

If we had taken S_2 as the leaving basic variable then the first iteration would be as follows:

Eqn. No.	Basic Variable	Coefficient of						RHS	Ratio
		Z	x	y	S_1	S_2	S_3		
0	-	1	-2	0	0	5	0	150	
1	S_1	0	1	0	1	0	0	40	40
2	y	0	0	1	0	1	0	30	∞
3	S_3	0	1	0	0	-1	1	0	0

Proceeding to the second iteration from this stage, second iteration will be as follows.

Second Iteration:

Eqn. No.	Basic Variable	Coefficient of						RHS
		Z	x	y	S_1	S_2	S_3	
0	-	1	0	0	0	3	2	150
1	S_1	0	0	0	1	1	-1	40
2	y	0	0	1	0	1	0	30
3	x	0	1	0	0	-1	1	0

The final solution is $Z^* = 150, S_1 = 40, y = 30, x = 0$.

The above table (final step) indicates that the basic variable x is equal to 0. This implies that if we have to decide the maximum profit with production of the two products, even without producing one product we still get the maximum profit. This is a degenerate optimal solution.

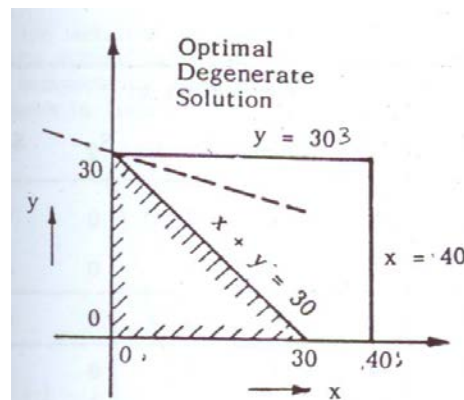

Note that the value of the variables in the first and second iterations is the same. At both iterations one of the basic variables is zero. If there is an indication of degeneracy in the first iteration itself, why don't we stop at the iteration when a degenerate solution appears? But we are not sure that this will coincide with the optimal. The optimal solution may not be degenerate.

4.11.4 Temporary Degenerate Solution

Example

$$\begin{aligned} &\text{Minimize} && Z = 2x + y \\ &\text{Subject to} && \\ &&& 4x + 3y \leq 12 \\ &&& 4x + y \leq 8 \\ &&& 4x - y \leq 8 \\ &&& x, y \geq 0 \end{aligned}$$

Solution:

Introducing slack variables, we get

$$\begin{aligned} Z - 2x - y &= 0 \\ 4x + 3y + S_1 &= 12 \\ 4x + y + S_2 &= 8 \\ 4x - y + S_3 &= 8 \end{aligned}$$

Starting table:

Eqn. No.	Basic Variable	Coefficient of						RHS	Ratio
		Z	x	y	S_1	S_2	S_3		
0	-	1	-2	-1	0	0	0		
1	S_1	0	4	3	1	0	0	3	
2	S_2	0	4	1	0	1	0	2	
3	S_3	0	4	-1	0	0	1	2	

First Iteration: x enters the basis and S_2 leaves

Eqn. No.	Basic Variable	Coefficient of						RHS	Ratio
		Z	x	y	S_1	S_2	S_3		
0	-	1	0	-1/2	0	1/2	0	4	
1	S_1	0	0	2	1	-1	0	2	
2	x	0	1	1/4	0	1/4	0	8	
3	S_3	0	0	-2	0	-1	1	-	

Note: S_3 cannot leave the basis according to the feasibility condition.

Second Iteration: y enters and S_1 leaves the basis.

Eqn. No.	Basic Variable	Coefficient of						RHS
		Z	x	y	S_1	S_2	S_3	
0	-	1	0	0	1/4	1/4	0	5
1	y	0	0	1	1/2	-1/2	0	2
2	x	0	1	0	-1/8	-3/8	0	3/2
3	S_3	0	0	0	1	-2	1	4

The optimal solution is $Z = 5$, $x = 3/2$, $y = 2$, $S_3 = 4$, $S_1 = S_2 = 0$.

Note that the solution in the first iteration is degenerate while the solution in the second and final iteration is non-degenerate. Hence the problem is temporarily degenerate.

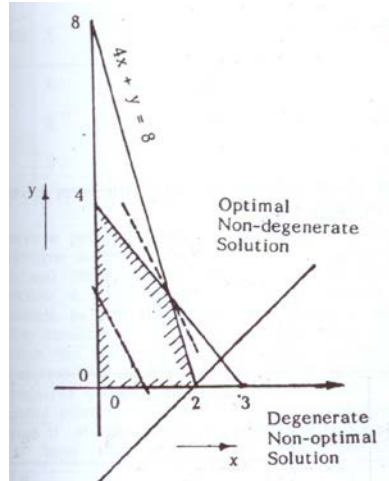

Sometimes it is possible that the simplex iterations will enter a loop which will repeat the same sequence of iterations without ever reaching an optimal solution. This peculiar problem is known as "cycling" or "circling" in linear programming. But the occurrence of such type of problem is very rare in practice. However, there are procedures developed to overcome such situations. Since it is rare the discussion is skipped.

4.11.5 Unbounded solution

In some of the linear programming problems the solution space becomes unbounded so that the value of the objective function also can be increased indefinitely without a limit. But it is wrong to conclude that just because the solution space is unbounded the solution also is unbounded. The solution space may be unbounded but the solution may be finite.

The following two problems illustrate these aspects.

Example (unbounded solution space and unbounded optimal solution)

$$\begin{aligned} \text{Maximize} \quad & Z = 3x + 2y \\ \text{Subject to} \quad & x - y \leq 15 \\ & 2x - y \leq 40 \\ & x, y \geq 0 \end{aligned}$$

Solution:

Convert the given problem into standard form by including slack variables. Thus we have

$$\begin{aligned} Z - 3x - 2y &= 0 \quad (0) \\ x - y + S_1 &= 15 \quad (1) \\ 2x - y + S_2 &= 40 \quad (2) \end{aligned}$$

Eqn. No.	Basic Variable	Coefficient of					RHS	Ratio
		Z	x	y	S_1	S_2		
0	-	1	-3	-2	0	0	0	
1	S_1	0	1	-1	1	0	15	15
2	S_2	0	2	-1	0	1	40	220

First Iteration: x enters and S_1 leaves basis.

Eqn. No.	Basic Variable	Coefficient of					RHS	Ratio
		Z	x	y	S_1	S_2		
0	-	1	0	-5	3	0	45	
1	x	0	1	-1	1	0	15	-15
2	S_2	0	0	1	-2	1	10	10

Second Iteration: y enters and S_2 leaves the basis.

Eqn. No.	Basic Variable	Coefficient of					RHS	Ratio
		Z	x	y	S_1	S_2		
0	-	1	0	0	-7	5	95	
1	x	0	1	0	-1	1	25	-25
2	y	0	0	1	-2	1	10	-5

Now we have a peculiar situation at the end of second iteration in which the objective function row indicates or suggests that S_1 is the entering variable and there is scope for further maximizing the value of objective function Z. But we are not in a position to select the leaving basic variable, as both the ratios are negative which cannot be taken as feasibility conditions. Thus we conclude that without removing either x or y from the basis we cannot further improve the value of the objective function Z, inspite of the scope for maximization as indicated by a negative coefficient in the objective row. Therefore we detect an unbounded solution to a linear programming problem from the simplex table that if at any iteration, any of the candidates for the entering variable have all negative or zero coefficients in the constraints.

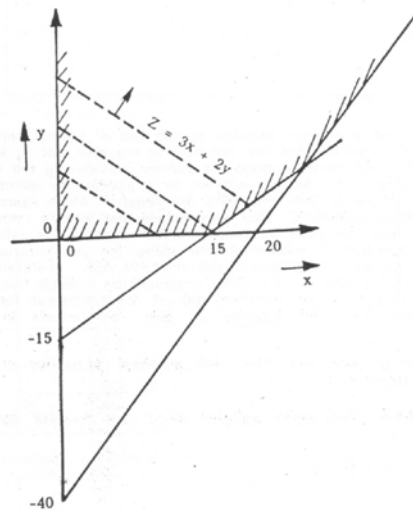

4.11.6 Unbounded solution space but bounded optimal solution

Example

$$\begin{aligned}
 &\text{Maximize} && Z = 3x - y \\
 &\text{Subject to} && \\
 &&& x - y \leq 10 \\
 &&& x \leq 20 \\
 &&& x, y \geq 0
 \end{aligned}$$

Solution:

Introducing slack variables and expressing the problem in the standard form we have

$$\begin{aligned} Z - 3x + y &= 0 & (0) \\ x - y + S_1 &= 10 & (1) \\ x + S_2 &= 20 & (2) \end{aligned}$$

Starting table

Eqn. No.	Basic Variable	Coefficient of					RHS	Ratio
		Z	x	y	S_1	S_2		
0	-	1	-3	1	0	0		
1	S_1	0	1	-1	1	10	10	
2	S_2	0	1	0	0	20	20	

First Iteration: x enters and S_1 leaves the basis.

Eqn. No.	Basic Variable	Coefficient of					RHS	Ratio
		Z	x	y	S_1	S_2		
0	-	1	0	-2	3	0	30	
1	x	0	1	-1	1	0	10	
2	S_2	0	0	1	-1	1	10	

Second Iteration: y enters and S_2 leaves the basis.

Eqn. No.	Basic Variable	Coefficient of					RHS
		Z	x	y	S_1	S_2	
0	-	1	0	0	1	2	50
1	x	0	1	0	0	1	20
2	y	0	0	1	-1	1	10

From the second iteration, we conclude that the optimal solution is

$$Z^* = 50, x = 20, y = 10, S_1 = S_2 = 0$$

The above problem is represented graphically in figure to indicate that there is a bounded optimal solution even though the solution space is unbounded.

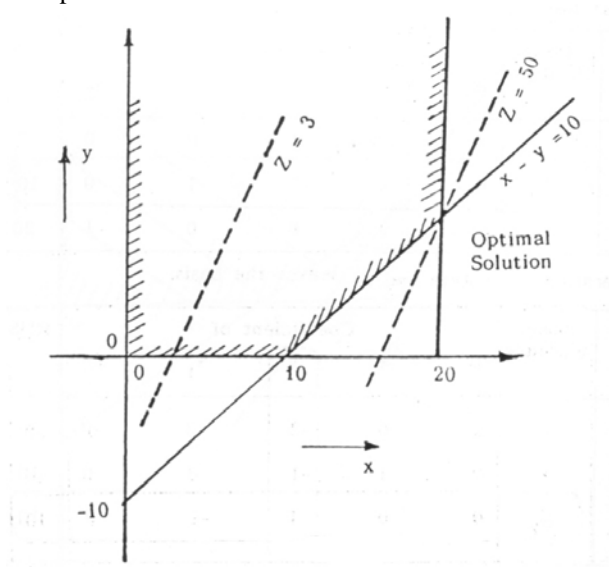

4.11.7 Multiple or Alternative optimal Solutions

In some of the linear programming problems we face a situation that the final basic solution to the problem need not be only one, but there may be alternative or infinite basic solutions, i.e., with different product mixes, we have the same value of the objective function line (namely the profit). This case occurs when the objective function line is parallel to a binding constraint line. Then the objective function takes the same optimal value at more than one basic solution. These are called alternative basic solutions. Any weighted average of the basic optimal solutions should also yield an alternative non-basic feasible solution, which implies that the problem will have multiple or infinite number of solutions without further change in the objective function. This is illustrated in the following example.

Example

$$\begin{array}{ll} \text{Maximize} & Z = 3x + 2y \\ \text{Subject to} & x \leq 40 \\ & y \leq 60 \\ & 3x + 2y \leq 180 \\ & x, y \geq 0 \end{array}$$

Solution:

With graphical approach as in figure it is evident that $x = 20, y = 60$ and $x = 40, y = 30$ are both basic feasible solutions and $Z^* = 180$. Since the two straight lines representing the objective function and the third constraint are parallel, we observe that as the line of objective function is moved parallel in the solution space in order to maximize the value, this objective line will coincide with the line representing the third constraint. This indicates that not only the two points $(20, 60)$ and $(40, 30)$ are the only basic solutions to the linear programming problem, but all points in the entire line segment between these two extreme points are basic optimal solution. Indeed we have infinite points and hence multiple non-basic feasible solution to the linear programming problem.

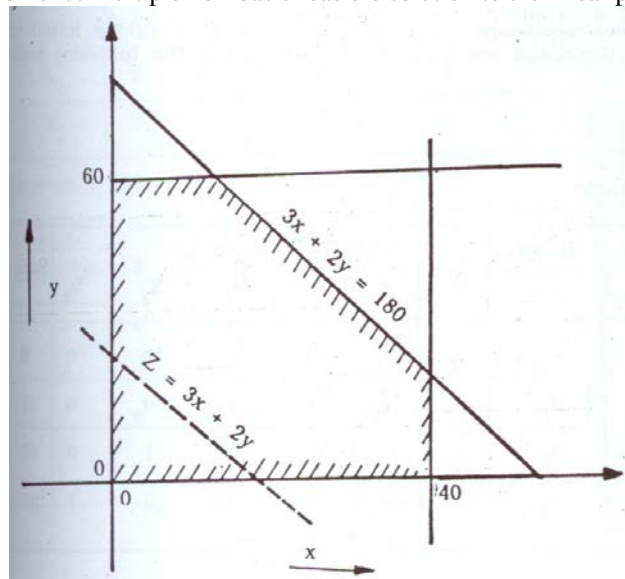

The same problem is now approached through simplex method to see how the simplex method provides a clue for the existence of other optimal solutions. We introduce slack variables to convert the problem into a standard form, which is presented below:

$$\begin{aligned} Z - 3x - 2y &= 0 & (0) \\ x + S_1 &= 40 & (1) \\ y + S_2 &= 60 & (2) \\ 3x + 2y + S_3 &= 180 & (3) \end{aligned}$$

The above equations are conveniently set down in the initial table and further iterations are carried out as shown in the following tables.

Initial Table

Eqn. No.	Basic Variable	Coefficient of						RHS	Ratio
		Z	x	y	S_1	S_2	S_3		
0	-	1	-3	-2	0	0	0	0	40
1	S_1	0	1	0	1	0	0	40	40
2	S_2	0	0	1	0	1	0	60	∞
3	S_3	0	3	2	0	0	1	180	60

First Iteration: x enters and S_2 leaves the basis.

Eqn. No.	Basic Variable	Coefficient of						RHS	Ratio
		Z	x	y	S_1	S_2	S_3		
0	-	1	0	-2	3	0	0	120	
1	x	0	1	0	1	0	0	40	∞
2	S_2	0	0	1	0	1	0	60	60
3	S_3	0	0	2	-3	0	1	60	30

Divide the equation 3 by 2 to make key No. 1

Eqn. No.	Basic Variable	Coefficient of						RHS	Ratio
		Z	x	y	S_1	S_2	S_3		
0	-	1	0	-2	3	0	0	120	
1	x	0	1	0	1	0	0	40	
2	S_2	0	0	1	0	1	0	60	60
3	S_3	0	0	1	-3/2	0	1/2	30	30

Second Iteration: y enters and S_3 leaves the basis.

Eqn. No.	Basic Variable	Coefficient of						RHS
		Z	x	y	S_1	S_2	S_3	
0	-	1	0	0	0	0	1	180
1	x	0	1	0	1	0	0	40
2	S_2	0	0	0	3/2	1	-1/1	30
3	y	0	0	1	-3/2	0	1/2	30

With this iteration we reach the optimal solution which is

$$x = 40, y = 30, S_2 = 30, S_1 = S_3 = 0, Z^* = 180$$

Now what is the clue that the problem has other optimal solutions?

We note from the second iteration that one of the non-basic variables, S_1 , has a zero coefficient in the current objective row, representing $Z = 180 + 0 S_1 - S_3$. Now as the non-basic variable S_1 is increased, the value of Z neither increases nor decreases so that the corresponding basic feasible solution should also be optimal.

We can find another optimal basic feasible solution by bringing the non-basic variable S_1 into the basis and the variable S_2 leaves the basis. We have another iteration performed as shown below.

Third iteration: S_1 enters and S_2 leaves the basis.

Eqn. No.	Basic Variable	Coefficient of						RHS
		Z	x	y	S_1	S_2	S_3	
0	1	0	0	0	0	-2	1	180
1	x	0	1	0	0	-2/3	1/3	20
2	S_1	0	0	0	3/2	1	-1/2	30
3	y	0	0	1	0	1	0	60

Hence $x = 20, y = 60, S_1 = 20, S_2 = S_3 = 0$ is another optimal basic feasible solution. Still another iteration can also be performed, as the current objective row has a zero coefficient for a non-basic variable. So we conclude that we have only two optimal basic feasible solutions for the problem. However, any weighted average of optimal solutions must also be optimal non-basic feasible solutions. Indeed there are infinite numbers of such solutions, corresponding to the points on the line segment between the two optimal extreme points.

The same idea can also be checked by counting the number of zero coefficients in the objective row in the optimal table. In all linear programming problems employing simplex method, there will be as many zero coefficients in the objective row as there are basic variables. But if we find that the optimal table contains more zero coefficients in the objective row than the number of variables in the basis, this is a clear indication that there will be yet another optimal basic feasible solution.

4.11.8 Non-existing feasible solution

This happens when there is no point in the solution space satisfying all the constraints. In this case the constraints may be contradictory or there may be inconsistencies among the constraints. Thus the feasible solution space is empty and the problem has no feasible graphical approach and then by the simplex method.

Example (no feasible solution)

$$\begin{array}{ll} \text{Maximize} & Z = 3x + 4y \\ \text{Subject to} & \end{array}$$

$$\begin{aligned} 2x + y &\leq 4 \\ x + 2y &\geq 12 \\ x, y &\geq 0 \end{aligned}$$

Solution: Introduce slack variables and artificial variable (for the constraint of the type \geq).

We have the standard form as

$$\begin{aligned} Z - 3x - 4y &= 0 \\ 2x + y + S_1 &= 4 \\ x + 2y - S_2 + A &= 12 \end{aligned}$$

Since artificial variable is introduced in the last constraint, a penalty of $+MA$ is added to the *L.H.S* of the objective row. Hence the objective function equation becomes, $Z - 3x - 4y + MA = 0$

Again the objective function should not contain the coefficients of basic variable. Thus we multiply the last constraint with $(-M)$ and add to the above equation. Thus we have,

$$Z - 3x - Mx - 4y - 2My + MS_2 = -12M \quad \text{as the objective function equation.}$$

Starting Table

Eq. No.	Basic Variable	Coefficient of						RHS	Ratio
		Z	x	y	S_1	S_2	A		
0	-	1	$-M-3$	$-2M-4$	0	M	0	$-12M$	
1	S_1	0	2	1	1	0	0	4	4
2	A	0	1	2	0	-1	1	12	6

First Iteration: y enters and S_1 leaves the basis.

Eq. No.	Basic Variable	Coefficient of						RHS
		Z	x	y	S_1	S_2	A	
0	-	1	$-3M+5$	0	$2M+4$	M	0	$-4M+16$
1	y	0	2	1	1	0	0	4
2	A	0	-3	0	-2	-1	1	4

The last iteration reveals that we cannot further proceed with maximization as there is no negative coefficient in the objective function row, but the final solution has the artificial variable in the basis with value at a positive level (equal to 4). This is the indication that the second constraint is violated and hence the problem has no feasible optimal solution.

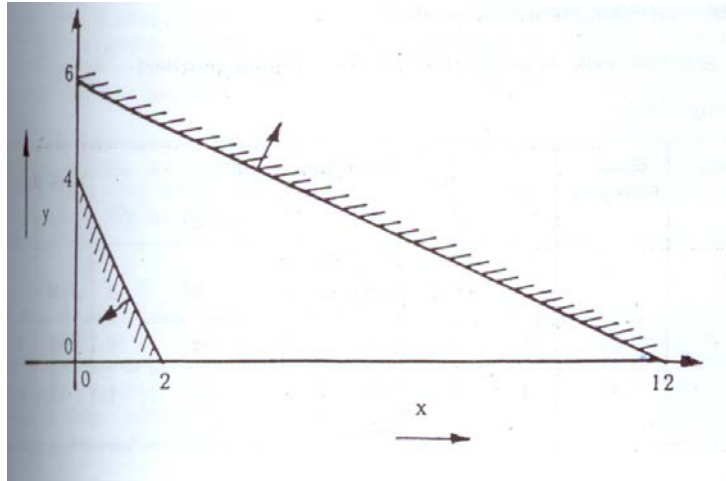

Therefore a linear programming problem has no feasible optimal solution if an artificial variable appears in the basis in the optimal table.

4.11.9 Unrestricted Variables

Thus far we have made the restrictions for the decision variables to be non-negative in most of the practical or real life problems. But there may be situations in which this is not always the case. However, the simplex method assumes non-negative variables. But if the problem involves variables with unrestricted in sign (the variables can take positive or negative or zero value), the problem can be converted into an equivalent one involving only non-negative variables.

A variable unrestricted in sign can always be expressed as the difference of two non-negative variables. If x is the variable unrestricted in sign, the same can be replaced with two other variables say m and n which are non-negative (> 0). Thus we have $x = m - n$

and since m and n are non-negative, the value of x will be positive if $m > n$, negative if $m < n$ and zero if $m = n$. Thus the values of m and n , which are non-negative, will decide the fate of the variable x . Since the simplex method examines the basic feasible solutions (extreme points), it will always have at least one of these two non-negative variables set equal to zero.

To illustrate we consider the following example.

Example

$$\begin{array}{ll} \text{Maximize} & Z = 2x + 5y \\ \text{Subject to} & \\ & x \leq 4 \\ & y \leq 3 \\ & x + y \leq 6 \\ & y \geq 0 \end{array}$$

Solution: Note that only y is non-negative and no mention is made about x . Hence x has to be treated as a variable unrestricted in sign. It can take any value positive, negative or zero.

$$\text{Let } x = m - n$$

Then we have an equivalent problem by replacing x by $(m - n)$,

$$\text{Maximize } Z = 2m - 2n + 5y$$

$$\begin{aligned} \text{Subject to } m - n &\leq 4 \\ y &\leq 3 \\ m - n + y &\leq 6 \\ m, n, y &\geq 0 \end{aligned}$$

Introduce slack variables and express the problem in the standard form. We have

$$\begin{aligned} Z - 2m + 2n - 5y &= 0 & (0) \\ m - n + S_1 &= 4 & (1) \\ y + S_2 &= 3 & (2) \\ m - n + y + S_3 &= 6 & (3) \end{aligned}$$

Starting Table:

Eq. No.	Basic Variable	Coefficient of							RHS	Ratio
		Z	m	n	y	S_1	S_2	S_3		
0	-	1	-2	2	-5	0	0	0	0	
1	S_1	0	1	-1	0	1	0	0	4	∞
2	S_2	0	0	0	1	0	1	0	3	3
3	S_3	0	1	-1	1	0	0	1	6	6

First Iteration: y enters and S_2 leaves the basis.

Eq. No.	Basic Variable	Coefficient of							RHS	Ratio
		Z	m	n	y	S_1	S_2	S_3		
0	-	1	-2	2	0	0	5	0	15	
1	S_1	0	1	-1	0	1	0	0	4	4
2	y	0	0	0	1	0	1	0	3	∞
3	S_3	0	1	-1	0	0	-1	1	3	3

Second Iteration: m enters and S_3 leaves the basis.

Eq. No.	Basic Variable	Coefficient of							RHS
		Z	m	n	y	S_1	S_2	S_3	
0	-	1	0	0	0	0	3	2	21*
1	S_1	0	0	0	0	0	1	-1	1
2	y	0	0	0	1	0	1	0	3
3	m	0	1	-1	0	0	-1	1	3

Therefore the solution to the original problem will be

$$\begin{aligned} Z^* &= 21 \\ x = m - n &= 3 \\ y &= 3 \\ S_1 = 1 \text{ and } S_2 = S_3 &= 0 \end{aligned}$$

If the original problem has more than one variable which is unrestricted in sign, then the procedure systematized by replacing each such unrestricted variable x_i by $x_j = m_j - n$ where $m_j \geq 0$ and $n \geq 0$, as before, but n is the same variable for all relevant j .

4.11.10 Exercise

Solve the Following Problems by the Simplex Method

1. Minimize $Z = 2x + y$
Subject to

$$\begin{aligned} x + 4y &\leq 1 \\ x + 2y &\geq 4 \\ x, y &\geq 0 \end{aligned}$$

2. Maximize $Z = 4x_1 + 2x_2 + x_3$
Subject to

$$\begin{aligned} x_1 + x_2 &\leq 1 \\ x_1 + x_3 &\leq 1 \\ x_1, x_2, x_3 &\geq 0 \end{aligned}$$

3. Maximize $Z = 4x_1 + 3x_2$
Subject to

$$\begin{aligned} 4x_1 + 2x_2 &\leq 10 \\ 6x_1 + 8x_2 &\leq 24 \\ x_1 \geq 0, x_2 &\geq 1.8 \end{aligned}$$

4. Maximize $Z = 3x_1 + x_2$
Subject to

$$\begin{aligned} 2x_1 + x_2 &\geq 4 \\ x_2 &\geq 2 \end{aligned}$$

5. Maximize $Z = 2x_1 + 3x_2 + 5x_3$
Subject to

$$\begin{aligned} 3x_1 + 10x_2 + 5x_3 &= 15 \\ 33x_1 - 10x_2 + 9x_3 &\leq 33 \\ x_1 + 2x_2 + x_3 &\geq 4 \\ x_1, x_2, x_3 &\geq 0 \end{aligned}$$

6. Use the simplex method to demonstrate that the following problem has an unbounded optimal solution.

Maximize $Z = 4x_1 + x_2 + 3x_3 + 5x_4$

Subject to

$$\begin{aligned} -4x_1 + 6x_2 + 5x_3 - 4x_4 &\leq 20 \\ 3x_1 - 2x_2 + 4x_3 + x_4 &\leq 10 \\ 8x_1 - 3x_2 + 3x_3 + 2x_4 &\leq 20 \\ x_1, x_2, x_3, x_4 &\geq 0 \end{aligned}$$

7. How do you identify multiple solutions in a linear programming problem using simplex procedure?

b) Maximize $Z = 3x_1 + 2x_2$
Subject to

$$\begin{aligned} x_1 &\leq 4 \\ x_2 &\leq 6 \\ 3x_1 + 2x_2 &\leq 18 \\ x_1, x_2 &\geq 0 \end{aligned}$$

8. Maximize $Z = 5u + 6v$

Subject to

$$\begin{aligned} 3u + v &\leq 1 \\ 3u + 4v &\leq 0 \end{aligned}$$

and u and v are unrestricted.

4.12 Duality Theory

For every linear programming problem, there is an associated linear programming problem and if the former problem is called the primal linear programming problem the latter is called its dual and vice versa. The concept of duality was also developed along with the linear programming discovery. It has many important ramifications. The two problems may appear to have only superficial relationship between each other, but they possess very intimately related properties and useful one, so that the optimal solution of one problem gives complete information about the optimal solution to the other.

We shall present later a few examples to illustrate how these relationships are useful in reducing computational effort while solving the linear programming problems. This concept of duality is very much useful to obtain additional information about the variations in the optimal solution when certain changes are effected in the constraint coefficients, resource availabilities and objective function coefficients. This is termed as post-optimality or sensitivity analysis.

4.12.1 Dual Formulation

The following procedure is generally adopted to convert the primal linear programming problem to its dual.

STEP 1 For each constraint in primal problem there is an associated variable in the dual problem.

STEP 2 The elements of the right hand side of the constraints in the primal problem are equal to the respective coefficients of the objective function in the dual problem.

STEP 3 When primal problem seeks maximization as the measure of effectiveness the dual problem seeks minimization and vice versa.

STEP 4 The maximization problem has constraints of type (\leq) and the minimization problem has constraints of the type (\geq).

STEP 5 The variables in both the problems are non-negative (sometimes unrestricted).

STEP 6 The rows of the primal problem are changed to columns in the dual problem.

Example

$$\begin{array}{ll} \text{Maximize} & Z = 6x_1 + 7x_2 + 8x_3 \\ \\ \text{Subject to} & x_1 + 2x_2 + 7x_3 \leq 60 \\ & 2x_1 \quad + 3x_3 \leq 20 \\ & 4x_2 + 5x_3 \leq 45 \\ & \quad \quad x_3 \leq 15 \\ & x_1, \quad x_2, \quad x_3 \geq 0 \end{array}$$

Solution: We consider the given problem as the primal linear programming problem. To convert into dual, the following procedure is adopted.

STEP 1 We have four constraints in the primal problem. So we choose four dual variables, say y_1, y_2, y_3 and y_4 . Connect these variables with the right hand side of each constraint, respectively.

STEP 2 The primal objective function is one of maximization. Hence, the dual seeks minimization for the objective function. The right hand side of the primal problem is associated with the respective dual variable and written as

$$\text{Minimize } Z = 60y_1 + 20y_2 + 45y_3 + 15y_4$$

STEP 3 Considering the primal problem, the matrix formed with constraint coefficients as elements in the matrix is transposed and the elements of transposed matrix will be coefficients of constraints for the dual problem. Note that the constraints in the primal problem are of the type (\leq). If any of the constraint is of the type (\geq) in a maximization problem convert into (\leq) inequality by multiplying the constraint throughout by (-1). In a minimization problem convert the inequality of the type (\leq) into (\geq) by multiplying the constraint by (-1).

In the above problem we have the coefficient matrix as

$$\begin{bmatrix} 1 & 2 & 7 \\ 2 & 0 & 3 \\ 0 & 4 & 5 \\ 0 & 0 & 1 \end{bmatrix}$$

The transpose of the above matrix is

$$\begin{bmatrix} 1 & 2 & 0 & 0 \\ 2 & 0 & 4 & 0 \\ 7 & 3 & 5 & 1 \end{bmatrix}$$

STEP 4 Treat the above elements as the coefficients for the constraints of the dual and the objective coefficient of the primal variables are taken as the right hand side for the constraints in the dual problem.

STEP 5 The dual problem seeks minimization and hence the constraints of the dual problem will have inequality of the type (\geq).

Hence we have the dual for the problem as follows:

$$\begin{aligned} \text{Minimize } & Z = 60y_1 + 20y_2 + 45y_3 + 15y_4 \\ \text{Subject to } & y_1 + 2y_2 \geq 6 \\ & 2y_1 + 4y_3 \geq 7 \\ & 7y_1 + 3y_2 + 5y_3 + y_4 \geq 8 \\ & y_1, y_2, y_3, y_4 \geq 0 \end{aligned}$$

4.12.2 Constraints having equality sign

An equality constraint in the primal problem corresponds to an unrestricted variable in sign in the dual problem and vice versa. To illustrate consider the example.

Example

$$\begin{aligned} \text{Maximize } & Z = c_1x_1 + c_2x_2 \\ \text{Subject to } & a_{11}x_1 + a_{12}x_2 = b_1 \\ & a_{21}x_1 + a_{22}x_2 \leq b_2 \\ & x_1, x_2 \geq 0 \end{aligned}$$

The first constraint has the equality sign. Hence this can be replaced by two equivalent constraints taken together as

$$\begin{aligned} & a_{11}x_1 + a_{12}x_2 \leq b_1 \\ \text{and } & a_{11}x_1 + a_{12}x_2 \geq b_1 \end{aligned}$$

or the same can be written as

$$\begin{aligned} & a_{11}x_1 + a_{12}x_2 \leq b_1 \\ \text{and } & -a_{11}x_1 - a_{12}x_2 \leq -b_1 \end{aligned}$$

Let y_1^+ , y_1^- and y_2 be the dual variables corresponding to the primal problem.

Thus the dual problem is

$$\begin{aligned} \text{Minimize} \quad & Z = b_1 (y_1^+ - y_1^-) + b_2 y_2 \\ \text{Subject to} \quad & a_{11} (y_1^+ - y_1^-) + a_{21} y_2 \geq c_1 \\ & a_{12} (y_1^+ - y_1^-) + a_{22} y_2 \geq c_2 \end{aligned}$$

and y_1^+ , y_1^- and $y_2 \geq 0$

The term $(y_1^+ - y_1^-)$ is observed in the objective function and all the constraints. This will be the case whenever there is an equality constraint in the primal. So if we replace $(y_1^+ - y_1^-)$ by a new variable y_1 which is the difference between two non-negative variables, the variable y_1 will become unrestricted in sign and the dual problem the variable y_1 will become unrestricted in sign and the dual problem is

$$\begin{aligned} \text{Minimize} \quad & Z = b_1 y_1 + b_2 y_2 \\ \text{Subject to} \quad & a_{11} y_1 + a_{21} y_2 \geq c_1 \\ & a_{12} y_1 + a_{22} y_2 \geq c_2 \end{aligned}$$

y_1 is unrestricted in sign

$$y_2 \geq 0$$

Thus we must have the dual variable corresponding to the equality constraint unrestricted in sign. Conversely, when a primal variable is unrestricted in sign, its dual constraint must be expressed as an equation.

The following examples reveal the conversion of the primal problem into dual.

Example

Write the dual of the following problem.

$$\begin{aligned} \text{Maximize} \quad & Z = -6x_1 + 7x_2 \\ \text{Subject to} \quad & -x_1 + 2x_2 \leq -5 \\ & 3x_1 + 4x_2 \leq 7 \\ & x_1, \quad x_2 \geq 0 \end{aligned}$$

Solution:

There are two constraints. Therefore we have two dual variables y_1 and y_2 . Then we have the dual as follows:

$$\begin{aligned} \text{Minimize} \quad & Z = -5y_1 + 7y_2 \\ \text{Subject to} \quad & -y_1 + 3y_2 \geq -6 \\ & 2y_1 + 4y_2 \geq 7 \\ & y_1, \quad y_2 \geq 0 \end{aligned}$$

Example

Write the dual of the problem

$$\begin{array}{ll}
 \text{Minimize} & Z = 5x_1 + 2x_2 \\
 \text{Subject to} & 6x_1 - 2x_2 + 2x_3 \geq 20 \\
 & 2x_1 + 4x_2 + x_3 \geq 40 \\
 & x_1, x_2, x_3 \geq 0
 \end{array}$$

Solution

Note that the objective function has coefficient 0 for x_3 .

$$\begin{array}{ll}
 \text{Maximize} & Z = 20y_1 + 40y_2 \\
 \text{Subject to} & 6y_1 + 2y_2 \leq 5 \\
 & -2y_1 + 4y_2 \leq 2 \\
 & 2y_1 + y_2 \leq 0 \\
 & y_1, y_2 \geq 0
 \end{array}$$

Example

Write the dual of the problem

$$\begin{array}{ll}
 \text{Maximize} & Z = 2x_1 + x_2 + 13x_3 - 5x_4 \\
 \text{Subject to} & -x_1 + x_2 + x_3 - x_4 = 15 \\
 & 6x_1 + 5x_2 - 7x_3 + 2x_4 \geq 18 \\
 & 10x_1 - 8x_2 + 2x_3 + 4x_4 \leq 25 \\
 & x_1, x_2, x_4 \geq 0 \\
 & x_3 \text{ is unrestricted.}
 \end{array}$$

Solution:

Before converting the problem into dual the following observations are made regarding the primal problem.

1. The objective function seeks maximization. Hence the constraints must be expressed as (\leq) type. The second constraint is of the type (\geq). It has to be converted into (\leq) by multiplying throughout the constraint by (-1).

i.e., $-6x_1 - 5x_2 + 7x_3 - 2x_4 \leq -18$

2. The first primal constraint has equality sign. Hence the corresponding dual variable will be unrestricted in sign and the third primal variable is unrestricted and so the corresponding third dual constraint will be an equation.

$$\begin{array}{ll}
 \text{Minimize} & Z = 15y_1 - 18y_2 + 25y_3 \\
 & -y_1 - 6y_2 + 10y_3 \geq 2 \\
 & y_1 - 5y_2 - 8y_3 \geq 1 \\
 & y_1 + 7y_2 + 2y_3 = 13 \\
 & -y_1 - 2y_2 + 4y_3 \geq -5 \\
 & y_1 \text{ is unrestricted} \\
 & y_2, y_3 \geq 0
 \end{array}$$

Example

Write the dual to the following problems, solve the dual and hence find the solution to the primal problem from the results of the dual.

$$\begin{array}{ll}
 \text{Minimize} & Z = 4x_1 + 3x_2 + 6x_3 \\
 \text{Subject to} & x_1 + x_3 \geq 2 \\
 & x_2 + x_3 \geq 5 \\
 & x_1, x_2, x_3 \geq 0
 \end{array}$$

Solution

The dual for the given problem can be easily written as

$$\begin{array}{ll}
 \text{Minimize} & Z = 2y_1 + 5y_2 \\
 \text{Subject to} & y_1 \leq 4 \\
 & y_2 \leq 3 \\
 & y_1 + y_2 \leq 6 \\
 & y_1, y_2 \geq 0
 \end{array}$$

(Note that it is easier to solve the dual problem than the primal since the primal problem involves the use of artificial variable technique and it may lead to tedious calculations.)

Introducing the slack variable for the constraints, we have

$$\begin{array}{ll}
 Z - 2y_1 - 5y_2 & = 0 \quad (0) \\
 y_1 + S_1 & = 4 \quad (1) \\
 y_2 + S_2 & = 3 \quad (2) \\
 y_1 + y_2 + S_3 & = 6 \quad (3)
 \end{array}$$

Starting table

Eq. No.	Basic Variable	Coefficient of						RHS	Ratio
		Z	y_1	y_2	S_1	S_2	S_3		
0	-	1	-2	-5	0	0	0	0	
1	S_1	0	1	0	1	0	0	4	∞
2	S_2	0	0	1	0	1	0	3	3
3	S_3	0	1	1	0	0	1	6	6

First Iteration: y_2 enters and S_2 leaves the basis.

Eq. No.	Basic Variable	Coefficient of						RHS	Ratio
		Z	y_1	y_2	S_1	S_2	S_3		
0	-	1	-2	0	0	5	0	15	
1	S_1	0	1	0	1	0	0	4	4
2	y_2	0	0	1	0	1	0	3	∞
3	S_3	0	1	0	0	-1	1	3	3

Second Iteration: y_1 enters and S_3 leaves the basis.

Eq. No.	Basic Variable	Coefficient of						RHS
		Z	y_1	y_2	S_1	S_2	S_3	
0	-	1	0	0	0	3	2	21*
1	S_1	0	0	0	1	1	-1	1
2	y_2	0	0	1	0	1	0	3
3	y_1	0	1	0	0	-1	1	3

The optimal solution to the dual problem as seen from the last table is

$$Z^* = 21; y_1 = 3, y_2 = 3, S_1 = 1, S_2 = S_3 = 0$$

The solution to the primal problem can be obtained from the optimal table of the dual problem by identifying the coefficients of those variables in the objective row of the optimal table which have been taken as the basic variables in the starting table of the dual problem.

In the above example, the variables, S_1 , S_2 and S_3 have been chosen to form the basis in the starting table of the dual. The corresponding coefficients of the same variables S_1 , S_2 and S_3 in the objective row of the optimal table are 0, 3 and 2 respectively and these are the optimal values of the variables in the primal problem namely,

$$\begin{aligned}x_1 &= 0 \\x_2 &= 3 \\x_3 &= 2\end{aligned}$$

Note that the objective function has the same value in both primal and dual problems.

The primal optimal solution is $Z^* = 21$, $x_1 = 0$, $x_2 = 3$ and $x_3 = 2$.

4.12.3 Economic Interpretation of the Dual

The duality concept has a natural economic interpretation, which is useful for economic analysis. We know that the linear programming problem is mainly concerned with the allocation of scarce resources among many activities in competition.

If

x_j is the level of activity j ,

c_j is the unit profit from activity expressed in rupees,

b_i is the amount of resource i available,

a_{ij} is the amount of resource i consumed by each unit of activity j ,

then consider a constraint from the corresponding dual problem.

$$a_{1j} y_1 + a_{2j} y_2 + \dots + a_{mj} y_m \geq c_j$$

We have from the primal problem, the unit of C_j is in rupees per unit of activity j and the units of a_{ij} are the units of resource i per unit of activity j . This implies that y_i must have units of rupees per unit of resource i . In other words, y_i may be interpreted as the unit prices of resource i in the sense of implicit or imputed value of the resource to the

user. Also, $\sum_{i=1}^{i=m} a_{ij} y_i$ can also be interpreted as the imputed cost of operating activity j at unit level.

The inequality, $\sum_{i=1}^{i=m} a_{ij} y_i \geq c_j$ suggests that this imputed cost should not be less than the profit, which could

be achieved from the activity. The dual objective $Z_y = \sum_{i=1}^{i=m} b_i y_i$

indicates that the prices of the resources should be set so as to minimize their total cost. The optimal value of the dual variables, y_i^* ($i = 1, 2, \dots, m$) then represents the incremental value, or shadow theorem $Zx^* = Zy^*$ implies that the total cost (implicit value) of the resources equals the total profit from the activities using them in an optimal manner.

It is interesting to note that the interpretation of y_i^* developed above is the rate at which the profit would change (increase or decrease) when the amount of resource i is changed (increased or decreased) over a certain range of b_i over which the original optimal basis is not changed. In fact y_i^* does represent the marginal value of resource i .

4.12.4 Applications of Duality

(a) From the theorems of duality we understand that solving either primal or the dual problem automatically solves the other problem. So we can apply simplex method to the problem requiring less computational effort, if we want to identify the optimal primal solution. The time consumed in a computer in using the simplex method is quite sensitive to the number of constraints. We also know that the number of original

variables in the primal problem is equal to the number of constraints in the dual problem whenever the original form of primal problem has more constraints than variables ($m > n$).

(b) Another important application of concept of duality is to the analysis of the problem if the parameters are changed after the original optimal solution has been obtained. This is normally dealt in the topic 'duality and post optimality analysis'.

(c) In duality analysis, we know that the value of the objective function for any feasible solution of the dual problem provides an upper bound to the optimal value of the objective function for the primal problem. This concept is useful to get an idea of how well or how much better one can do by expending the effort needed to obtain the primal solution.

To illustrate, consider the following primal linear programming problem.

$$\begin{array}{ll} \text{Maximize} & Z_x = 3x_1 + 4x_2 \\ \text{Subject to} & x_1 \leq 3 \\ & x_2 \leq 4 \\ & x_1 + x_2 \leq 5 \\ \text{and} & x_1, x_2 \geq 0 \end{array}$$

The dual of the above problem can be written as

$$\begin{array}{ll} \text{Minimize} & Z_y = 3y_1 + 4y_2 + 5y_3 \\ \text{Subject to} & y_1 + y_3 \geq 3 \\ & y_2 + y_3 \geq 4 \\ \text{and} & y_1, y_2, y_3 \geq 0 \end{array}$$

If we assume feasible values of $y_1 = 3$, $y_2 = 4$ and $y_3 = 0$, the objective function value $Z_y = 3y_1 + 4y_2 + 5y_3 = 25$. So, without further investigation, it will be clear that $Z_x = 25$. In fact the maximum value $Z_x^* = 17$ as obtained by simplex method.

4.12.5 Exercise

1. Find the dual of the following Problems

- (a)
$$\begin{array}{ll} \text{Maximize} & x_1 + 3x_2 \\ \text{Subject to} & 6x_1 + 19x_2 \leq 100 \\ & 3x_1 + 5x_2 \leq 40 \\ & x_1 - 3x_2 \leq 33 \\ & x_2 \leq 25 \\ & x_1 \leq 42 \\ & x_1, x_2 \geq 0 \end{array}$$
- (b)
$$\begin{array}{ll} \text{Maximize} & P = x_1 + 2x_2 \\ \text{Where} & x_1 \geq 0, x_2 \geq 0 \\ \text{and} & x_1 + 2x_2 \leq 10 \\ & -x_1 - x_2 \leq 30 \end{array}$$
- (c)
$$\begin{array}{ll} \text{Maximize} & 2x_1 + x_2 + x_3 - x_4 \\ \text{Subject to} & x_1 + 3x_2 + x_3 + 2x_4 \leq 2 \\ & 3x_1 + 3x_2 + 2x_3 + 2x_4 \leq 4 \end{array}$$
- (d)
$$\begin{array}{ll} \text{Subject to} & x_1 - x_2 + 2x_3 + 2x_4 \leq 3 \\ & 2x_1 + 2x_2 - x_3 = 4 \\ & x_1 - 2x_2 + 3x_3 + 4x_4 \geq 5 \\ & x_1 - 2x_2 + 3x_3 + 4x_4 \geq 5 \\ & x_1, x_2, x_3 \geq 0 \\ & x_4 \text{ unrestricted.} \end{array}$$
- (e)
$$\begin{array}{ll} \text{Maximize} & x_0 = 15x_1 + 3x_2 + 16x_3 \\ & x_1 + x_2 - x_3 + 2x_4 \leq 2 \\ & x_1 + x_2 - x_3 \leq 2 \\ & x_1 + 13x_2 + x_3 = 2 \\ & x_1, x_2, x_3 \geq 0 \end{array}$$

4- Linear Programming

VU

$$\begin{aligned} 3x_1 + 2x_2 + 4x_3 + 5x_4 &\leq 6 \\ x_1, x_2, x_3, x_4 &\geq 0 \end{aligned}$$

(f) Maximize $Z = x_1 + 1.5x_2$

Subject to

$$\begin{aligned} 2x_1 + 3x_2 &\leq 25 \\ x_1 + x_2 &\geq 1 \\ x_1 - 2x_2 &= 1 \\ x_1, x_2 &\geq 0 \end{aligned}$$

(g) Maximize $x_0 = 2x_1 + 3x_3$

Subject to

$$\begin{aligned} -3x_1 + x_2 + 2x_3 &\leq 5 \\ -2x_1 - x_2 &\leq 1 \\ x_1, x_2, x_3 &\geq 0 \end{aligned}$$

5 Transportation Models

5.1 Introduction

Many practical problems in operations research can be broadly formulated as linear programming problems, for which the simplex this is a general method and cannot be used for specific types of problems like,

- (i) transportation models,
- (ii) transshipment models and
- (iii) the assignment models.

The above models are also basically allocation models. We can adopt the simplex technique to solve them, but easier algorithms have been developed for solution of such problems. The following sections deal with the transportation problems and their streamlined procedures for solution.

In a transportation problem, we have certain origins, which may represent factories where we produce items and supply a required quantity of the products to a certain number of destinations. This must be done in such a way as to maximize the profit or minimize the cost. Thus we have the places of production as origins and the places of supply as destinations. Sometimes the origins and destinations are also termed as sources and sinks.

To illustrate a typical transportation model, suppose m factories supply certain items to n warehouses. Let factory i ($i = 1, 2, \dots, m$) produce a_i units and the warehouse j ($j = 1, 2, \dots, n$) requires b_j units. Suppose the cost of transportation from factory i to warehouse j is C_{ij} . Let us define the decision variables x_{ij} being the amount transported from the factory i to the warehouse j . Our objective is to find the transportation pattern that will minimize the total transportation cost.

The model of a transportation problem can be represented in a concise tabular form with all the relevant parameters mentioned above. See table 1

Table 1

Origins (Factories)	Destinations (Warehouses)			Available
	1	2 n	
1	c_{11}	c_{12}	c_{1n}	a_1
2	c_{21}	c_{22}	c_{2n}	a_2
...
m	c_{m1}	c_{m2}	c_{mn}	a_m
Required	b_1	b_2	b_n	

The pattern of distribution of items in the form of transportation matrix is separately given below in table 2.

Table 2

Origins	Destinations			Available
	1	2 n	
1	x_{11}	x_{12}	x_{1n}	a_1
2	x_{21}	x_{22}	x_{2n}	a_2
...
m	x_{m1}	x_{m2}	x_{mn}	a_m
Required	b_1	b_2	b_n	

5.2 Transportation Model as a Linear Programming Problem

The transportation problem can be represented mathematically as a linear programming model. The objective function in this problem is to minimize the total transportation cost given by

$$Z = c_{11} x_{11} + c_{12} x_{12} + \dots + c_{mn} x_{mn}$$

Subject to the restrictions:

row restrictions

$$\begin{aligned} x_{11} + x_{12} + \dots + x_{1n} &= a_1 \\ x_{21} + x_{22} + \dots + x_{2n} &= a_2 \\ &\vdots \\ x_{m1} + x_{m2} + \dots + x_{mn} &= a_m \end{aligned}$$

Column restrictions

$$\begin{aligned} x_{11} + x_{21} + \dots + x_{m1} &= b_1 \\ x_{12} + x_{22} + \dots + x_{m2} &= b_2 \\ &\vdots \\ x_{1n} + x_{2n} + \dots + x_{mn} &= b_n \end{aligned}$$

and

$$x_{11}, x_{12}, \dots, x_{mn} \geq 0$$

It should be noted that the model has feasible solutions only if

$$a_1 + a_2 + \dots + a_m = b_1 + b_2 + \dots + b_n \quad \text{or} \quad \sum_{i=1}^m a_i = \sum_{j=1}^n b_j$$

The above is a mathematical formulation of a transportation problem and we can adopt the linear programming technique with equality constraints. Here the algebraic procedure of the simplex method may not be the best method to solve the problem and hence more efficient and simpler streamlined procedures have been developed to solve transportation problems.

5.3 Formulations of a transportation problem

A company has plants located at three places where the production pattern is described in the following table.

Plant location	1	2	3
Production (units)	40	70	90

The potential demand at five places has been estimated by the marketing department and is presented below.

Distribution centre	1	2	3	4	5
Potential demand (units)	30	40	60	40	60

The cost of transportation from a plant to the distribution centre has been displayed in the table

Table 3

Distribution centers

Plant	1	2	3	4	5
1	20	25	27	20	15
2	18	21	22	24	20
3	19	17	20	18	19

Represent the above data in a table to represent a transportation problem.

Solution:

In this example the total supply and the total demand do not match as supply is less than demand. Hence a dummy row (dummy plant) is introduced at a unit transportation cost of 0. The following is the tabular representation of the transportation problem.

Note: If the total demand (requirements) is less than the total supply (availability), a dummy column (dummy destination) is introduced with a unit transportation cost of 0.

Table 4

	Distribution center					
Plant	1	2	3	4	5	Supply
1	20	25	27	20	15	40
2	18	21	22	24	20	70
3	19	17	20	18	19	90
4	0	0	0	0	0	30
Demand	30	40	60	40	60	230

5.4 Initial Basic Feasible Solution

An initial basic feasible solution to a transportation problem can be found by any one of the three following methods:

- (i) North west corner rule (NWC)
- (ii) Least cost method (LCM)
- (iii) Vogel's approximation method (VAM)

5.4.1 North West Corner Rule

STEP 1 Start with the cell in the upper left hand corner (North West Corner).

STEP 2 Allocate the maximum feasible amount.

STEP 3 Move one cell to the right if there is any remaining supply. Otherwise, move one cell down. If both are impossible, stop or go to step (2).

An example is considered at this juncture to illustrate the application of NWC rule.

Example 2
Table 5

Destinations

Origin	P	Q	R	Supply
A	5	7	8	70
B	4	4	6	30
C	6	7	7	50
Demand	65	42	43	150

In table 5 supply level, demands at various destinations, and the unit cost of transportation are given. Use NWC rule to find the initial solution.

Solution:

The solution obtained by the North West Corner Rule is a basic feasible solution. In this method we do not consider the unit cost of transportation. Hence the solution obtained may not be an optimal solution. But this will serve as an initial solution, which can be improved.

We give below the procedure for the solution of the above problem by NWC rule.

The North West Corner cell (AP) is chosen for allocation. The origin A has 70 items and the destination P requires only 65 items. Hence it is enough to allot 65 items from A to P. The origin A which is alive with 5 more items can supply to the destination to the right is alive with 5 more items can supply to the destination to the right of P namely Q whose requirement is 42. So, we supply 5 items to Q thereby the origin A is exhausted. Q requires 37 items more. Now consider the origin B that has 30 items to spare. We allot 30 items to the cell (BQ) so that the origin B is exhausted. Then move to origin C and supply 7 more items to the destination Q. Now the requirement of the destination Q is complete and C is left with 43 items and the same can be allotted to the destination R. Now the origin C is emptied and the requirement at the destination R is also complete. This completes the initial solution to the problem.

The above calculations are performed conveniently in a table 6 as shown below:

Table 6
Destinations

Origin	P	Q	R			
A	65	5		70	65	0
B		30		30	0	
C		7	43	50	7	43 0
	65	42	43			
	0	37	0			
		0				

The total cost of transportation by this method will be

$$65 \times 5 + 5 \times 7 + 30 \times 4 + 7 \times 7 + 43 \times 7 = \text{Rs. } 830.$$

As the solution obtained by the North West Corner Rule may not be expected to be particularly close to the optimal solution, we have to explore a promising initial basic feasible solution, so that we can reach the optimal solution to the problem with minimum number of iterations.

5.4.2 Least Cost Method

STEP 1: Determine the least cost among all the rows of the transportation table.

STEP 2: Identify the row and allocate the maximum feasible quantity in the cell corresponding to the least cost in the row. Then eliminate that row (column) when an allocation is made.

STEP 3: Repeat steps 1 and 2 for the reduced transportation table until all the available quantities are distributed to the required places. If the minimum cost is not unique, the tie can be broken arbitrarily.

To illustrate, consider the example repeated in table 7

Table 7

Destination

Origin	P	Q	R	Supply
A	5	7	8	70
B	4	4	6	30
C	6	7	7	50
Demand	65	42	43	
	55			

We examine the rows A, B and C, 4 is the least cost element in the cell (B,P) and (B, Q) and the tie can be broken arbitrarily. Select (B, P). The origin B can supply 30 items to P and thus origin B is exhausted. P still requires 35 more units. Hence, deleting the row B, we have the reduced matrix as in the table 8

Table 8

Destination

Origin	P	Q	R	Supply
A	5	7	8	70
C	6	7	7	50
Demand	35	42	43	
	0			

In the reduced matrix (table 8) we observe that 5 is the least element in the cell (A, P) and examine the supply at A and demand at P. The destination P requires 35 items and this requirement is satisfied from A so that the column P is deleted next. So we have the reduce matrix as in table 9

Table 9

Destination

Origin	Q	R	Supply
A	35		35
	7	8	
C	7	7	50
Demand	42	43	
	7		

In the reduced matrix (table 9) we choose 7 as least element corresponding to the cell (A, Q). We supply 35 units from A to Q so have the reduced matrix in table 10.

Table 10

Destination

Origin	Q	R	Supply
A	7	43	50
	7	8	
Demand	7	43	
	0	0	

Now, only one row is left behind. Hence, we allow 7 items from C to Q and 43 items C to R.

We now have the allotment as per the least cost method as shown in the table 11

Table 11

Destination

Origin	P	Q	R	Supply
A	35	35		70
B	30			30
C		7	43	50
Demand	65	42	43	

The cost of the allocation by the least cost method is $35 \times 5 + 35 \times 7 + 30 \times 4 + 7 \times 7 + 43 \times 7 = \text{Rs. } 890$

5.4.3 Vogel's Approximation Method (VAM)

This method is based on the 'difference' associated with each row and column in the matrix giving unit cost of transportation c_{ij} . This 'difference' is defined as the arithmetic difference between the smallest and next to the smallest element in that row or column. This difference in a row or column indicates the minimum unit penalty incurred in failing to make an allocation to the smallest cost cell in that row or column. This difference also provides a measure of proper priorities for making allocations to the respective rows and column. In other words, if we take a row, we have to allocate to the cell having the least cost and if we fail to do so, extra cost will be incurred for a

wrong choice, which is called penalty. The minimum penalty is given by this difference. So, the procedure repeatedly makes the maximum feasible allocation in the smallest cost cell of the remaining row or column, with the largest penalty. Once an allocation is fully made in a row or column, the particular row or column is eliminated. Hence an allocation already made cannot be changed. Then we have a reduced matrix. Repeat the same procedure of finding penalty of all rows and columns in the reduced matrix, choosing the highest penalty in a row or column and allotting as much as possible in the least cost cell in that row or column. Thus we eliminate another fully allocated row or column, resulting in further reducing the size of the matrix. We repeat till all supply and demand are exhausted.

A summary of the steps involved in Vogel's Approximation Method is given below:

STEP 1: Represent the transportation problem in the standard tabular form.

STEP 2: Select the smallest element in each row and the next to the smallest element in that row. Find the difference. This is the penalty written on the right hand side of each row. Repeat the same for each column. The penalty is written below each column.

STEP 3: Select the row or column with largest penalty. If there is a tie, the same can be broken arbitrarily.

STEP 4: Allocate the maximum feasible amount to the smallest cost cell in that row or column.

STEP 5: Allocate zero else where in the row or column where the supply or demand is exhausted.

STEP 6: Remove all fully allocated rows or columns from further consideration. Then proceed with the remaining reduced matrix till no rows or columns remain.

Let us apply Vogel's Approximation Method to the above example as given below in table 12

Origin	Destination			Supply	Row difference
	P	Q	R		
A	5	7	8	70	(2)
B	4	30	6	30	0
		4			(0)
C	6	7	7	50	(1)
Demand	65	42	43		
		12			
Column difference	(1)	(3)	(1)		
					Largest Penalty

The difference between the smallest and next to the smallest element in each row and in each column is calculated. This is indicated in the parenthesis. We choose the maximum from among the differences. The first individual allocation will be to the smallest cost of a row or column with the largest difference. So we select the column Q (penalty = 3) for the first individual allocation, and allocate to (B, Q) as much as we can, since this cell has the least cost location. Thus 30 units from B are allocated to Q . This exhausts the supply from B . However, there is still a demand of 12 units from Q . The allocations to other cells in that column are 0, as indicated. The next step is to write down the reduced matrix (as in table 13) eliminating row B (as it is exhausted).

Table 13

Origin	Destination			Supply	Row difference
	P	Q	R		
A	65	7	8	70	5
	5				(2)
C	6	7	7	50	(1)
Demand	65	12	43		
	0				
Column difference	(1)	(0)	(1)		

From the table 13, (2) is the largest unit difference corresponding to the row A . This leads to an allocation in the corresponding minimum cost location in row A , namely cell (A, P) . The maximum possible allocation is only 65 as required by P from A and allocation of 0 to others in the row A . Column P is thus deleted and the reduced matrix is given in table 14.

Maximum difference is 1 in row A and in column C. Select arbitrarily A and allot the least cost cell (A, Q) 5 units. Delete row A.

Now, we have only one row C and two columns Q and R (Table 15) indicating that all the available amount from C has to be moved to Q and R as per their requirements. Hence we have the table 15

Table 14

Origin	Destination		Supply	Row difference
	P	R		
A	5	8	5	0
C	7	7	50	(1)
Demand	12	43		
	7			

Column difference (0) (1)

Table 15

Origin	Destination		Supply
	Q	R	
C	7	43	50
	7	7	
	7	43	
	0	0	

Table 16

Origin	Destination			Supply
	P	Q	R	
A	65	5		70
B		30		30
C		7	43	50
Demand	65	42	43	

We obtain as our basic feasible solution by re-tracking various positive allocations in successive stages. We have the solution by Vogel's Approximation Method as shown in the table 16

The cost of allocation by Vogel's Approximation Method will be

$$65 \times 5 + 5 \times 7 + 30 \times 4 + 7 \times 7 + 43 \times 7$$

$$= 325 + 35 + 120 + 49 + 301 = \text{Rs. } 830.$$

Note:

Cost of allocation for the same problem with three methods:

NWC method - Rs. 830/-

Least cost method - Rs.890/-

Vogel's Approximation Method - Rs. 830/

Generally VAM gives a better initial solution.

5.5 Exercise

1. What do you mean by transportation problem?
2. What do you mean by feasible solution and basic feasible solution of transportation problem?
3. Describe Transportation problem. Give a method of finding an initial feasible solution.
4. Explain in brief with examples.
 - (i) North West Corner rule.
 - (ii) Vogel's Approximation Method.
5. Explain the classical transportation problem and write down its mathematical formulation and show that it is a particular case of a linear programming problem.
6. A petroleum company has three major oil fields and five oil refineries. The shipping costs from the fields to the refineries, fields are as shown in the table.

Refinery Capacity		Production	
Refinery	Barrels per day	Field	Barrels per day
A	10,000	1	20,000
B	13,000	2	25,000
C	13,000	3	30,000
D	16,000		
E	18,000		

Cost per Barrel (Rs.)

Field	A	B	C	D	E
1	400	300	330	380	360
2	350	350	380	320	350
3	370	300	400	350	340

- Determine the optimum scheme using the North West Corner Rule.
 Determine the optimum scheme using the Least Cost Method.
 Determine the optimum scheme using Vogel's Approximation Method.
 Compare the computations

5.6 Moving Towards Optimality

5.6.1 The rationale behind optimality

Given an initial non-degenerate basic feasible solution, a question may arise as to how we can find a successively better basic feasible solution. This means that we have to select an entering variable, a leaving basic variable and identify the corresponding solution. In the transportation model, selecting an entering variable means selecting a new cell in which to make a non-zero allocation in the transportation matrix. The principle of selecting the variable which improves the value of the objective function (minimizes the total transportation cost), at the fastest rate is still valid. So we select an unoccupied cell and make a unit allotment, so that the cost of transportation will decrease by the greatest amount.

To illustrate, suppose that in the example 4.1 we choose arbitrarily the cell (B, P) which is unoccupied and make + 1 allotment in this cell. This new allocation automatically violates the supply situation and demand requirements of the origin B and destination P. So changes are required in other cells to restore feasibility. This necessitates a reallocation in the cells to restore feasibility. This necessitates a reallocation in the cells (B, P), (A, P), (A, Q) and (B, Q). The row total and column total will be unaltered. This idea is illustrated in tables 17 to 19.

Table 17

	P	Q	R
A	5	7	8
B	4	4	6
C	6	7	7

Unit cost of transportation

Table 18

	P	Q	R	
A	65	5		70
B		30		30
C		7	43	50
	65	42	43	

Table 19

	P	Q	R	
A	65-1	5+1		70
B	1	30-1		30
C		7	43	50
	65	42	43	

Changed allotment

The unit costs in the cells (B, P), (A, P), (A, Q) and (B, Q) are 4, 5, 7, 4 respectively (refer table 17). The total change in the total cost will be $4 - 5 + 7 - 4 = + 2$. We see that this arbitrary unit allotment to cell (B, P) increases the transportation cost by rupees 2. Hence an allocation to the cell (B, P) is not recommended.

This procedure is repeated by choosing some other unoccupied cell for allocation. This requires corresponding changes in the allocation in the occupied cells to restore feasibility and calculation of the marginal cost. If, by this procedure, we get a +ve value, it indicates that the total cost is not decreasing but increasing.

Consider the objective function to minimize,

$$Z = \sum_{i=1}^m \sum_{j=1}^n c_{ij} x_{ij}$$

and the restrictions as

$$0 = a_i - \sum_{j=1}^n x_{ij} \quad \text{for } i = 1, 2, \dots, m$$

$$0 = b_j - \sum_{i=1}^m x_{ij} \quad \text{for } j = 1, 2, \dots, n$$

Multiply each of these equations by a number and add this multiple to the objective function. This resultant can be used to eliminate the basic variable. Let us represent the multiples by u_i ($i = 1, 2, \dots, m$) and v_j ($j = 1, 2, \dots, n$) respectively for rows and columns. These multipliers are called the simplex multipliers.

Therefore,

$$\begin{aligned} Z &= \sum_{i=1}^m \sum_{j=1}^n c_{ij} x_{ij} + \sum_{i=1}^m u_i \left[a_i - \sum_{j=1}^n x_{ij} \right] \\ &\quad + \sum_{j=1}^n v_j \left[b_j - \sum_{i=1}^m x_{ij} \right] \\ &= \sum_{i=1}^m \sum_{j=1}^n (c_{ij} - u_i - v_j) x_{ij} + \sum_{i=1}^m u_i a_i + \sum_{j=1}^n v_j b_j \end{aligned}$$

Thus in order to have a zero coefficient (for a basic variable) it is necessary that

$$c_{rs} = u_r + v_s$$

for each basic variable x_{rs} (i.e.) for each occupied cell (r, s). There are $(m + n - 1)$ occupied cells and therefore $(m + n - 1)$ equations. Since we have $(m + n)$ unknown (u_i 's and v_j 's) one of these variables can be assigned a value arbitrarily and rest of them can then be solved algebraically. This leads to the solution of a set of $(m + n - 1)$ equations simultaneously.

Having determined the values of u_i and v_j , the entering basic variable (if any) can be identified readily by calculating $c_{ij} - (u_i + v_j)$ for each of the unoccupied cells. If $c_{ij} - (u_i + v_j) \geq 0$ in every case, then the solution must be optimal since no non-basic variable can decrease Z . On the other hand if $c_{ij} - (u_i + v_j)$ yields a negative result, the cell with the largest negative (smallest) value of $c_{ij} - (u_i + v_j)$ is selected to be the cell for new allocation since it means that this non-basic variable decreases Z at the fastest rate. This is the basis for conducting the optimality test, which is explained in the next section.

5.6.2 Optimality test

For conducting the optimality test to any feasible solution of a ($m \times n$) transportation problem, the following two conditions must be satisfied.

1. It consists of **exactly** ($m + n - 1$) individual cells being allocated.
2. These allocations are in independent positions.

The first condition is normally satisfied in many problems. If the first condition is not satisfied then it results in a state known as degeneracy, in the transportation mode. The discussion of degeneracy and its resolution is explained in a later section.

A set of allocations comprising a feasible solution is said to be in 'independent positions' if it is impossible to increase or decrease any individual allocation without either changing the positions of allocations or violating the row or column restrictions. In other words, a simple criterion for independence is that, it is impossible to travel from any allocation back to itself, by a series of alternating horizontal and vertical jumps from one occupied cell to another, without a direct reversal of route.

For example, if the occupied cells form a closed loop as in table 20 they are not in independent positions

Table 20

*		*
*		*

Applying the procedure outlined above to the initial basic feasible solution, (found by any method) we have the following steps in conducting an optimality test.

STEP 1: Write the matrix of allotment found by NWC rule or by Vogel's Approximation Method. Check for conditions for optimality (i.e.) there must be ($m + n - 1$) allotted cells and all of them must be in independent positions. If these two conditions are satisfied, proceed to step 2.

STEP 2: Write the matrix of the cost of the allotted cells.

STEP 3: Determine a set of ($m + n$) numbers,

$$u_i, \quad i = 1, 2, \dots, m$$

$$v_j, \quad j = 1, 2, \dots, n$$

called simplex multipliers such that for each occupied cell (r, s).

$$c_{rs} = u_r + v_s$$

where c_{rs} is the individual cost of an allocation from origin r to destinations s .

This can be done by arbitrarily assigning, any one of the u_i 's or v_j 's, any value (say 0) and satisfying the above equation for all the occupied cells.

STEP 4: Write the matrix of cost elements for all unoccupied cells.

STEP 5: Find ($u_r + v_s$) for each unoccupied cell and form the matrix of ($u_i + v_j$) for each of the unoccupied cell.

STEP 6: Calculate $c_{ij} - (u_i + v_j)$ for each of the unoccupied cells. This is the matrix of cell evaluation or square evaluation. If the value of cell evaluation is positive, it indicates that the solution already found is optimal. If it is negative there is a scope for relocation of items so that the total cost of transportation can be made minimum. If there are many negative entries in the matrix of cell evaluation, select the cell yielding the most negative entry as the entering variable. This requires reallocation of the allocation matrix. By including this cell for occupation, the allocations of the other occupied cells require a revision to fulfill the row and column restrictions. If the value of cell evaluation is zero, then this indicates that there exists another solution to the transportation problem without reducing the total cost.

Consider the example whose cost matrix is as in table 21

Table 21

Origin	Destination			Supply	
	P	Q	R		
A	5	7	8	70	Cost Matrix
B	4	4	6	30	
C	6	7	7	50	
Demand	65	42	43		

We have the allocation as per NWC rule as in table 22

Table 22

Origin	Destination			Supply	
	P	Q	R		
A	65	5		70	Allotment Matrix
B		30		30	
C		7	43	50	

Next we write the matrix of the cost of allotted cells and using explained below and shown in table 23

Table 23

Origin	Destination			u_i		
	P	Q	R			
A	5	7	-	u_1	0	Finding u_i, v_j using the cost of the occupied cells
B	-	4	-	u_2	-3	
C	-	7	7	u_3	0	
v_j	v_1	v_2	v_3			
	5	7	7			

To determine u_i 's and v_j 's we arbitrarily assign one of the multipliers say u_3 the value 0. Then it follows that $v_2 = 7$ because we have the equation

$$u_3 + v_2 = 7$$

Since $u_3 + v_3 = 7$

we have $v_3 = 7$

Similarly using the cost elements of the occupied cells and with the equation $c_{rs} = u_r + v_s$, we can find the values of u_i 's and v_j 's.

The unoccupied (un-allotted) cells are indicated by placing dots in the cells.

Next we write the matrix of the cost elements c_{ij} of the unoccupied cells as in table 24.

Table 24

Origin	Destination		
	P	Q	R
A			8
B	4		6
C	6		

cost of unoccupied cells

Next we write the matrix of $u_i + v_j$ for unoccupied cells as in

Table 25

Origin	Destination		
	P	Q	R
A			7
B	2		4
C	5		

$(u_i + v_j)$ for unoccupied cells

Table 26

Origin	Destination		
	P	Q	R
A			1
B	2		2
C	1		

Cell Evaluation

Next we write the matrix of $u_i + v_j$ for unoccupied cells as in table 25. Next we find $c_{ij} - (u_i + v_j)$ for all the unoccupied cells. This matrix is obtained by subtracting the elements in the $(u_i + v_j)$ matrix from the corresponding elements of c_{ij} in the matrix of the cost of unoccupied cells. This is the matrix of cell evaluation or square evaluation as shown in table 26.

We see that all the elements of the matrix of cell evaluation are positive (> 0). This indicates that our initial basic solution is optimal and the cost of transportation is Rs. 830. If the elements of matrix of cell evaluation are negative, it indicates that further reduction in cost is possible.

Example

Mam enterprise has three factories located at A, B and C and supplies to three warehouses located at D, E and F. Monthly factory capacities are 10, 80 and 15 units respectively. Monthly warehouse requirements are 45, 20 and 40 units respectively. Unit transportation costs in rupees are given below.

	Warehouse		
Factory	D	E	F
A	5	1	7
B	6	4	6
C	3	2	5

Starting with NWC rule, find the optimal allotment.

Solution:

Using NWC rule we obtain the initial basic feasible solution as in table 27.

Table 27

Warehouse				Supply	45	25	0
Factory	D	E	F				
A	10			10			0
B	35	20	25	80			0
C			15	15			0
	45	20	40				
	35		15				
	0	0	0				

There are five allotments. As per the optimality test conditions there must be $(3 + 3 - 1)$ cells occupied and we see that this condition is satisfied. Secondly all the cells should be in independent positions.

To test the cells whether they are independent or not, we take an occupied cell and alter the allotment in that cell by one unit. This requires the change in other occupied cells without violating the constraints. Or if we start from one occupied cell and we do come back to the starting cell, then the cells are in dependent positions. In the above problem all the cells are independent.

Having satisfied the two conditions we proceed to the optimality test as described above and are carried in tables 28 to 33

Table 28

Factory	Warehouse		
	D	E	F
A	5	1	7
B	6	4	6
C	3	2	5

Cost Matrix

Table 29

Factory	Warehouse		
	D	E	F
A	10		
B	35	20	25
C			15

Allotment Matrix

Table 30

Factory	Warehouse			u_i	
	D	E	F		
A	5	-	-	u_1	0
B	6	4	6	u_2	1
C	-	-	5	u_3	0
v_i	v_1	v_2	v_3		
	5	3	5		

Evaluation u_i and v_j

Table 31

Factory	Warehouse		
	D	E	F
A		1	7
B			
C	3	2	

Cost of un-allotted cells

Table 32

Factory	Warehouse		
	D	E	F
A		3	5
B			
C	5	3	

$(u_i + v_j)$ for un-allotted cells

Table 33

Factory	Warehouse		
	D	E	F
A		-2	2
B			
C	-2	-1	

Cell Evaluation

In the matrix of cell evaluation, there are three cells (A, E), (C, D), and (C, E) having negative entries indicating the scope of minimizing the cost by bringing any of these cells for occupation. But the most negative element is found in two cells (A, E) and (C, D). Since there is a tie, the same is broken arbitrarily. We select the cell (C, D) for reallocation (as marked in table 34). With the initial feasible solution,

Table 34

Factory	Warehouse		
	D	E	F
A	10		
B	35	20	25
C			15

we have to allocate as much as possible in the empty cell (with the mark) with the most negative evaluation to arrive at the minimum cost as quickly as possible. The reallocation is performed by identifying the loop joining the empty cell to the occupied cells by horizontal and vertical jumps as indicated in table 35.

Table 35

Factory	Warehouse		
	D	E	F
A	10		
B	35	20	25
C			15

It can be seen that we can allocate 15 units to cell (C, D) and still satisfy the row and column total and thus no allocation becomes negative. The effect of allotting 15 units to empty cell leads to the matrix of reallocation as shown in table 36.

Table 36

Factory	Warehouse		
	D	E	F
A	10		
B	20	20	40
C	15		

Reallotment among cells of loop

We conduct optimality test to see whether this solution is optimal. The computations are carried in tables 37 to 42. From the table 42 we see that the unoccupied cell (A, E) has a negative evaluation and hence there exists another feasible solution as shown in table 4

We have to conduct the optimality test to find whether the third feasible solution is optimal. By carrying out the iterations (not shown), we observe that the third feasible solution (Table 43) is optimal and the corresponding cost is

$$10 \times 1 + 30 \times 6 + 10 \times 4 + 40 \times 6 + 15 \times 3 = \text{Rs. } 515.$$

Table 37

Factory	Warehouse		
	D	E	F
A	5	1	7
B	6	4	6
C	3	2	5

Cost Matrix

Table 38

Factory	Warehouse		
	D	E	F
A	10		
B	20	20	40
C	15		

Allotment Matrix

Table

39

Factory	Warehouse			u_i
	D	E	F	
A	5			-1
B	6	4	6	0
C	3			-3
v_j	6	4	6	

Cost of allotted cells & Evaluation of u_i and v_j

Table 40

Factory	Warehouse		
	D	E	F
A		1	7
B			
C		2	5

Cost of unallotted cells

Table 41

Factory	Warehouse		
	D	E	F
A		3	5
B			
C		1	3

$(u_i + v_j)$ for unallotted cells

Table 42

Factory	Warehouse		
	D	E	F
A		-2	2
B			
C		1	2

Cell Evaluation

Table 43

Factory	Warehouse		
	D	E	F
A		10	
B	30	10	40
C	15		

Reallotment

5.7 VAM for maximization problem

The VAM method can be used in a maximization problem making a slight modification. The required modification is to multiply all the elements in the (profit) matrix by -1, with the concept that minimizing the negative of a function maximizes the original function.

Consider the example given below.

Example: Solve the following transportation problem to maximize profit and give criteria for optimality.

Profits (Rs) / Unit

		Destination				
Origin	1	2	3	4	Supply	
A	40	25	22	33	100	
B	44	35	30	30	30	
C	38	38	28	30	70	
Demand	40	20	60	30		

Solution: We first convert the elements of profit matrix by multiplying by -1 and then we adopt the method of minimization. This is done in table 44

Table 44

		Destination				
Origin		1	2	3	4	Supply
A		-40	-25	-22	-33	100
B		-44	-35	-30	-30	30
C		-38	-38	-28	-30	70
	Demand	40	20	60	30	

In the above problem total supply is not equal to total demand. (supply demand) and hence it is an unbalanced transportation model. To balance, we introduce a dummy column 5. to find the initial feasible solution by VAM. We put the elements in the dummy column 90 as in table 45

Table 45

		Destination					
Origin		1	2	3	4	Supply	Penalty
A		-40	-25	-22	-33	100	(7)
B		-44	-35	-30	-30	30	(9)
C		-38	-38	-28	-30	70	(0)
	Demand	40	20	60	30		
	Penalty	(4)	(3)	(2)	(3)		

Allot in the row B having maximum penalty and in the cell (B, I) with least cost.

The origin B is deleted for further analysis as it is exhausted. We have the reduced matrix given in table 46.

Table 46

		Destination						
Origin		1	2	3	4	5	Supply	Penalty
A		-40	-25				100	(7)
C		-38	20	-28	-30	0	70	(0)
	Demand	10	20	60	30	50		
	Penalty	(2)	(13)	(6)	(3)	(0)		

Allot in the column (2), which has a maximum penalty (13) and in the cell (C, 2) with least cost. Column 2 is deleted as the supply is satisfied and we have the reduced matrix as in table 46

Table 47

Origin	Destination				Supply	Penalty	
	1	3	4	5			
A	-40	-22	-33	0	100	(7)	
C	10	-28	-30	0			
	Demand	10	60	30	0	50	(8)
	Penalty	(2)	(6)	(3)	(0)		

Allot (C, 1) with 10 units and delete column 1. Then we have table 48

Table 48

Origin	Destination			Supply	Penalty
	3	4	5		
A	-22	30	0	100	(11)
		-33			
C	-28	-30	0	40	(2)
Demand	60	30	50		
Penalty	(6)	(3)	(0)		

Allot 30 to cell (A, 4) and delete column 4. Then we have table 49

Table 49

Origin	Destination		Supply	Penalty
	3	5		
A	-22	0	70	(22)
	40			
C	-28	0	40	(28)
Demand	60	50		
Penalty	(6)	(0)		

Deleting row C we have the table 50 as we allot 40 to cell (C, 3).

Table 50

Origin	Destination		Supply
	3	5	
	20	50	
A	-22	0	70
Demand	20	50	

Thus we have the initial feasible solution given in table 51

Table 51

Origin	Destination				
	1	2	3	4	5
A			20	30	50
B					
C	10	20	40		

Allotment Matrix

The optimality test is conducted table 52 to 55

Table 52

Origin	Destination					u_i
	1	2	3	4	5	
A	-	-	-22	-30	0	6
B	-44	-	-	-	-	-6
C	-38	-38	-28	-	-	0
v_j	-38	-38	-28	-36	-6	

Evaluation of u_i 's and v_j 's

Table 53

Origin	Destination				
	1	2	3	4	5
A	-40	-25			
B		-35	-30	-30	0
C				-30	0

Cost of un-allotted cells

Table 54

Origin	Destination				
	1	2	3	4	5
A	-32	-32			
B		-44	-34	-42	-12
C				-36	-6

$(u_i + v_j)$ for unallotted cells

From table 55 see that the cell (A, 1) has a negative value indicating that there is scope for optimality. This is a potential box to be allotted. Therefore we go back to the allotment matrix in table 51. Allotting to cell (A, 1) we have to remove from cell (A, 3), add to cell (C, 3) and remove from cell (C, 1) so that the loop is complete indicating that reallocation is possible. Now we have to decide the amount to be allotted and this is decided with the idea that in the process of reallocation no cell can have negative allotment. Hence we have the new allotment as per the following table 56

Table 55

Origin	Destination				
	1	2	3	4	5
A	-8	-7			
B		9	4	12	12
C				6	6

Cell Evaluation

Table 56

Origin	Destination				
	1	2	3	4	5
A	10		10	30	50
B	30				
C		20	50		

Reallotment

Table 57

Origin	Destination					u_i
	1	2	3	4	5	
A	-40	-	-22	-33	0	0
B	-44	-	-	-	-	-4
C		-38	-28	-	-	-6
v_j	-40	-32	-22	-33	0	

Evaluation of u_i and v_j

Table 58

Origin	Destination				
	1	2	3	4	5
A		-25			
B		-35	-30	-30	0
C	-38			-30	0

Cost of unallotted cells

Table 59

Origin	Destination				
	1	2	3	4	5
A		-32			
B		-36	-26	-37	-4
C	-46			-39	-6

$(u_i + v_j)$ for unallotted cells

Table 60

Origin	Destination				
	1	2	3	4	5
A		7			
B		1	-4	7	4
C	8			9	6

Cell Evaluation

The matrix of cell evaluation of cell evaluation in table 60 shows a negative entry in the cell (B, 3) indicating that this is a potential cell for allotment so that we get a better result. Hence we make a reallocation as shown by dotted lines in table 61.

Table 61

Origin	Destination				
	1	2	3	4	5
A	20			30	50
B	20		10		
C		20	50		

Reallotment

We can conduct once again the optimality test. One more iteration would reveal that the allotments in the table 61 are optimal. This iteration is left to the reader. Hence the profit

$$= (20 \times 40) + (30 \times 33) + (20 \times 44) + (50 \times 0) + (10 \times 30) + (20 \times 38) + (50 \times 20) = Rs.5130.$$

5.8 Exercise

1. Solve the following transportation problem for minimization (Unit costs are given in rupees).

Destination

Origin	D ₁	D ₂	D ₃	D ₄	D ₅	Supply
01	4	3	1	2	6	40
02	5	2	3	4	5	30
03	3	5	6	3	2	20
04	2	4	4	5	3	10
Demand	30	30	15	20	5	

2. A manufacturer has distribution centres at X, Y and Z. These centres have availability of 40, 20 and 40 units of the product, His retail outlets at A, B, C, D and E require 25, 10, 20, 30 and 15 units respectively. The transport cost per unit between each centre and each outlet is given below.

Retail Outlets

Distribution Centre	A	B	C	D	E
X	55	30	40	50	50
Y	35	30	100	45	60
Z	40	60	95	35	30

Determine the optimal distribution to minimize the cost of transportation.

3. (a) A company has three warehouses, W_1 , W_2 and W_3 and four retail stores S_1 , S_2 , S_3 and S_4 . The availability of a given commodity at these warehouses are as follows: $W_1 = 14$, $W_2 = 16$, $W_3 = 5$. The demands at these stores are: $S_1 = 6$, $S_2 = 10$, $S_3 = 15$, $S_4 = 4$. The costs of transporting one unit of the commodity from warehouse i to store j , in rupees, are given in the following table.

	S ₁	S ₂	S ₃	S ₄
W ₁	6	4	1	5
W ₂	8	9	2	7
W ₃	4	3	6	2

Determine the optimum transportation schedule, which minimizes the total transportation cost.

4. A firm manufacturing a single product has three plants at locations X, Y and Z. The three plants have produced 60, 35 and 40 units respectively during the week. The firm has made commitments to sell 22, 45, 20, 18 and 30 units of the product to customers A, B, C, D and E respectively. The net per unit cost of transporting from the three plants to the five customers is given in the table below.

Customers

Plant Locations	A	B	C	D	E
X	4	1	3	4	4
Y	2	3	2	2	3
Z	3	5	2	4	4

Use Vogel's approximation method to determine the cost of shifting the product from plant locations to the customers. Does your solution provide a least cost transportation schedule?

5. A steel company has three furnaces and five rolling mills. Transportation costs (Rupees per quintal) for sending steel from furnaces to rolling mills are given in the following table.

Rolling Mills

Furnaces	M ₁	M ₂	M ₃	M ₄	M ₅	Availability
A	4	2	3	2	6	8
B	5	4	5	2	1	12
C	6	5	4	7	3	14
Required	4	4	10	8	8	

How should they meet the requirement?

6. A company has three factories at A, B and C, which supply warehouses at D, E, F and G respectively. Monthly product capacities of these factories are 250, 300 and 400 units respectively. The current warehouse requirements are 200, 275 and 300 units respectively. Unit transportation costs from factories to warehouses are given below.

To	D	E	F	G
A	11	13	17	14
B	16	18	14	10
C	21	24	13	10

Determine the optimum distribution to minimize cost.

7. Solve the following transportation problem for minimization, the cost matrix is given as:

	D ₁	D ₂	D ₃	D ₄	D ₅	a _i
O ₁	12	4	9	5	9	55
O ₂	8	1	6	6	7	45
O ₃	1	12	4	7	7	30
O ₄	10	15	6	9	1	50
b _j	40	20	50	30	40	

Find all the alternate optimal solutions.

8. Solve the following transportation problem for minimization.

To	I	II	III	IV	V	a _i
A	20	19	14	23	16	40
B	15	20	13	19	16	60
C	18	15	18	20	100	70
b _j	30	40	50	40	60	

9. Pir Iron and Steel Company (PISCO) has three open hearth furnaces and five rolling mills. Transportation costs (Rs. per quintal) for shipping steel from furnaces to rolling mills are shown in the following table.

Mills

Furnaces	M ₁	M ₂	M ₃	M ₄	M ₅	Capacities
F ₁	4	2	3	2	6	8
F ₂	5	4	5	2	1	12
F ₃	6	5	4	7	7	14
Required	4	4	10	8	8	

What is an optimal shipping schedule for PISCO?

10. A company having plants at *P*, *Q* and *R* supplies to the warehouses at *W*, *X*, *Y* and *Z*. Monthly plant capacities are 75, 95, and 120 respectively. Monthly warehouse requirements are 55, 65, 75 and 100 respectively. Unit shipping costs are as follows.

	W	X	Y	Z
P	18	21	15	12
Q	16	22	26	15
R	16	15	16	17

Determine the optimum distribution for this company to minimize the shipping costs using VAM for initial solution.

11. The Products of three plants *F*₁, *F*₂ and *F*₃ are to be transported to 5 warehouses *W*₁, *W*₂, *W*₃, *W*₄ and *W*₅. The capacities of plants, the requirements of ware houses and the cost of transportation are indicated in the following table.

	W ₁	W ₂	W ₃	W ₄	W ₅	Plant Capacity
F ₁	74	56	54	62	68	400
F ₂	58	64	62	58	54	500
F ₃	66	70	52	60	60	600
Demand	200	280	240	360	320	

Find the optimum transportation schedule and the associated cost of transportation.

12. Goods are to be transported from three warehouses to six customers. The availabilities at the warehouses are 100, 120 and 150 units respectively. The demands of customers are 50, 40, 50, 90, 60 and 80 respectively. The unit transportation costs are given in the following table.

	C ₁	C ₂	C ₃	C ₄	C ₅	C ₆
W ₁	15	25	18	35	40	26
W ₂	22	36	40	60	50	38
W ₃	26	38	45	52	45	48

- a) Develop an optimum transportation schedule and give the minimum transportation cost.
 b) Is it possible to have more than one optimum schedule? If so, give at least one more optimum schedule.

13. Peru enterprise has three factories at location A, B and C, which supplies three warehouses, located at D, E and F. Monthly factory capacities are 10, 18 and 15 units respectively. Monthly warehouse requirements are 75, 20 and 50 units respectively.

Warehouse

Factory	D	E	F
A	5	1	7
B	6	4	6
C	3	2	5

The penalty costs for not satisfying demand at the warehouses D , E and F are Rs. 5, Rs. 3, and Rs. 2 per unit respectively. Determine the optimal distribution for Peru using any of the known algorithms.

14. A fleet operator has in his three depots P, Q and R 1 bus and 8 buses and 7 buses respectively. He has to allocate them to those bus stands X, Y and Z, which require 2, 5 and 9 buses respectively. The following table gives the distances in kilometers from each depot to each bus stand. Find the optimum allocation.

	X	Y	Z
P	6	4	12
Q	10	6	5
R	15	16	8

15. A firm has 4 factories, which produce 8, 7, 9 and 4 units respectively of a product. The firm owns three stores, which sells 8 units respectively. The unit transportation cost is given below in the table.

Store

Factory	A	B	C
P	10	9	8
Q	10	7	10
R	11	9	7
S	12	14	10

Find the transportation schedule, which minimizes the distribution cost.

5.9 Degeneracy

In the examples discussed so far, the solution procedure yielded exactly $(m + n - 1)$ strictly positive allocations, in independent positions indicating non-degenerate basic feasible solution. When either of the conditions for conducting optimality is absent it results in a degenerate solutions. The circumstances in many cases may not yield result, which satisfy conditions for optimality tests. We may have less number of cells allotted even in the initial basic feasible solution, found, either by North West Corner rule or other methods described previously. It may be sometimes non-degenerate in the initial basic feasible solution but at any intermediate iteration (while we conduct the optimality test) it may lead to a case of a degenerate feasible solution. This particularly occurs when a row and a column simultaneously vanish, while making allocations initially by any of the methods. The situation of degeneracy can be resolved as explained in the next paragraph.

A feasible solution with independence, but with fewer than the required number of individual allocations is changed to become permissible in the following way. We have to choose the required number of cells, such that this number plus the existing allocation come to exactly $(m + n - 1)$ cells should be in independent positions. Then, an infinitesimal but positive allocation, say an amount equal to ϵ is allotted to each of the chosen unoccupied cells. This fictitious allotment does not change the physical nature of the original set of allocations, but will be helpful to carry out the iterations. This small fictitious quantity plays an auxiliary role and it is removed when the optimum is reached.

Sometimes a feasible solution may degenerate to $m + n - 3$ or even fewer independent allocations. In such cases, if the transportation method is to be adopted in finding a solution to the problem, we will have to introduce two or more infinitesimal variables (ϵ). The ϵ 's are also placed in various independent positions and can be distinguished from each other by subscripts.

Example: Solve the following transportation problem to minimize the total cost of transportation.

Destination

Origin	1	2	3	4	Supply
1	14	56	48	27	70
2	82	35	21	81	47
3	99	31	71	63	93
Demand	70	35	45	60	210

Solution: First obtain an indicial basic feasible solution with Vogel's Approximation Method from the table 62

Table 62

Destination

Origin	1	2	3	4	Supply	Penalty
	70					
1	14	56	48	27	70	(13)
2	82	35	21	81	47	(14)
3	99	31	71	63	93	(32)
Demand	70	35	45	60	210	
Penalty	(68)	(4)	(36)	(36)		

Supply 70 to 1 from 1. Hence row 1 and column 1 are both eliminated. The reduced matrix is shown in table 63

Table 63

Destination

Origin	2	3	4	Supply	Penalty
		45			
2	35	21	81	47	(14)
3	31	71	63	93	(32)
Demand	35	45	60	140	
Penalty	(4)	(50)	(18)		

Supply 45 to 3 from 2 and hence column 3 is eliminated, resulting in table 64

Table 64

Destination

Origin	2	4	Supply
	2		
2	35	81	2 (46)
3		63	93 (32)
Demand	35	60	95
Penalty	(4)	(18)	

Supply 35 items from origin 2 to destination 2 and row 2 is deleted.

Table 65

Destination

Origin	2	4	Supply
	33	60	
3	31	63	93
Demand	33	60	93

Summarising the above results we have the initial feasible allocation as exhibited in table 66

Table 66

Destination

Origin	1	2	3	4	Supply
1	70				70
2		2	45		47
3		33		60	93
Demand					

Cost: $70 \times 14 + 2 \times 35 + 45 \times 21 + 33 \times 31 + 60 \times 63 = \text{Rs. } 6798/-$

Table 67

	Destination			
Origin	1	2	3	4
1	14	56	48	27
2	82	35	21	81
3	99	31	31	63

Cost matrix

To conduct the optimality test for the above solution there must be $6 (= 3 + 4 - 1)$ cells to which allocation must have been made. But we have made allotment to 5 cells only. Hence this is a degenerate basic feasible solution.

To resolve the case of degeneracy, we introduce a very small quantity ϵ in a vacant and independent cell. In the above problem we allot ϵ to cell (1, 4), which is independent. The optimality test can now be conducted as shown in the following tables 68 to 72.

Table 68

	Destination			
Origin	1	2	3	4
1	70			ϵ
2		2	45	
3		33		60

Allotment matrix

Table 69

	Destination					
Origin	1	2	3	4	u_i	
1	14	-	-	27	u_1	0
2	-	35	21	-	u_2	40
3	-	31		63	u_3	36
v_j	v_1	v_2	v_3	v_4		
	14	-5	-19	27		

Cost of allotted cells and $(u_i + v_j)$

Table 70

	Destination			
Origin	1	2	3	4
1		56	48	
2	82			81
3	99		71	

Cost of unallotted cells

Table 71

Origin	Destination			
	1	2	3	4
1		-5	-19	
2	54			67
3	50		17	

$(u_i + v_j)$ for unallotted cells

Table 72

Origin	Destination			
	1	2	3	4
1		61	67	
2	28			14
3	49		54	

Cell evaluation

In table 72 (matrix of cell evaluation) there is no negative entry indicating that the solution found in table 66 is optimal.

The optimum cost = Rs. 6698

5.10 Exercise

1. What do you understand by degeneracy in a transportation problem?
2. What is degeneracy?
3. Write a short note on degeneracy in a transportation problem.
4. Explain how degeneracy in a transportation problem may be resolved.
5. How the problem of degeneracy arises in a transportation problem?
6. A company has three plants at locations A, B and C which supply to warehouses located at D, E, F, G and H. Monthly plant capacities are 800, 500 and 900 units respectively. Monthly warehouse requirements are 400, 400, 500, 400 and 800 units respectively. Unit transportation costs (in Rupees) are given below.

To

	D	E	F	G	H
A	5	8	6	6	3
B	4	7	7	6	5
C	8	4	6	6	4

Determine an optimum distribution for the company in order to minimize the total transportation cost.

7. A company has four manufacturing plants and five warehouses. Each plant manufactures the same product, which is sold at different prices at each warehouse area. The cost of manufacturing and cost of raw materials are different in each plant due to various factors. The capacities of the plants are also different. These data are given in the following table:

Item/Plants	1	2	3	4
Manufacturing Cost (Rs.) per unit	12	10	8	7
Raw material Cost (Rs.) per unit	8	7	7	5
Capacity per unit time	100	200	120	80

The company has five warehouses. The sale prices, transportation costs and demands are given in the following table:

Warehouse	Transportation Cost (Rs.) per unit				Sale Price (Rs.) Per Unit	Demand
	Plants 1	2	3	4		
A	4	7	4	3	30	80
B	8	9	7	8	32	120
C	2	7	6	10	28	150
D	10	7	5	8	34	70
E	2	5	8	9	30	90

- (i) Formulate this into a transportation problem to maximize profit.
- (ii) Find the solution using VAM method.
- (iii) Test for optimality and find the optimal solution.

6 Assignment Models

6.1 introduction

A special type of problem called the assignment problem is also an allocation problem. Here we have n jobs to perform with n persons and the problem is how to distribute the jobs to the different persons involved. Depending on the intrinsic capacity or merit or potential of the individual, he will be able to accomplish the task in different times. Then the objective function in assigning the different jobs to different persons is to find the optimal assignment that will minimize the total time taken to finish all the jobs by the individuals. For example, we have four different building activities say, construction of a hotel, a theatre, a hospital and a multistoried building and there are four contractors competing for these jobs. Each contractor has to be assigned only one job. The allocation should aim to minimize the total time taken to complete the construction of all four activities after assigning only one job to one individual. In fact there are $(4!)$ permutations possible for allocating 4 jobs to 4 contractors. We have 24 possible ways and it is tiresome to list all the possible ways and find the best one. If we have more jobs to be allocated, it is even difficult to list out the different permutations of allocations, then what to speak of choosing the best combinations!

The problem may be stated formally as follows. Given an $n \times n$ array of real numbers representing the individual return associated with assigning one item to one person. We have to find the best assignment so that the total return is optimal.

Consider the following example, given below in the table 1

Table 1

Jobs	Men			
	A	B	C	D
1	5	6	8	7
2	4	7	6	6
3	5	4	6	5
4	6	7	4	6

In the above example, the elements of the matrix represent the times taken by A, B, C and D in accomplishing the jobs 1, 2, 3 and we have to find which job is to be assigned to whom so that the total time taken will be minimum. This is the objective function. Thus, this is also an allocation problem. A solution can be found to the above problem by the algorithm used to solve the transportation problem of degenerate transportation problem. In this way only 4 cells will be allocated. This leads to problem of degenerate transportation problem. There should be $(4 + 4 + 1) = 7$ allocations in the initial basic feasible solution, but we have only 4 allocations. Hence it is the degeneracy.

6.2 Mathematical Formulation of the Assignment Problem

Considering the above example, we have four jobs and four persons. We want to allot one job to one person so that the total time taken will be minimum. We shall formulate a mathematical model for the problem.

Let the decision variable x_{ij} be the assignment of i^{th} job to j^{th} person, and c_{ij} be the time taken for i^{th} job by the j^{th} person.

The objective function is to minimize
$$z = \sum_{i=1}^n \sum_{j=1}^n c_{ij} x_{ij}$$

Subject to restrictions,

Row restrictions

$$x_{11} + x_{12} + x_{13} + x_{14} = 1 \quad \text{for job 1}$$

$$\begin{aligned}x_{21} + x_{22} + x_{23} + x_{24} &= 1 && \text{for job 2} \\x_{31} + x_{32} + x_{33} + x_{34} &= 1 && \text{for job 3} \\x_{41} + x_{42} + x_{43} + x_{44} &= 1 && \text{for job 4}\end{aligned}$$

Column restrictions

$$\begin{aligned}x_{11} + x_{21} + x_{31} + x_{41} &= 1 && \text{for person 1} \\x_{12} + x_{22} + x_{32} + x_{42} &= 1 && \text{for person 2} \\x_{13} + x_{23} + x_{33} + x_{43} &= 1 && \text{for person 3} \\x_{14} + x_{24} + x_{34} + x_{44} &= 1 && \text{for person 4}\end{aligned}$$

and $x_{ij} = 0$ or 1

In general,

$$x_{i1} + x_{i2} + \dots + x_{in} = 1, \quad \text{for } i = 1, 2, \dots, n$$

and $x_{1j} + x_{2j} + \dots + x_{nj} = 1, \quad \text{for } j = 1, 2, \dots, n$

When compared with a transportation problem, we see that $a_i = 1$ and $b_j = 1$ for all rows and columns, $x_{ij} = 0$ or 1 .

We shall not attempt simplex algorithm or the transportation algorithm to get a solution to an assignment problem. Certain systematic procedure has been devised so as to obtain the solution to the problem with ease.

6.3 Solution of an Assignment Problem

The solution to an assignment problem is based on the following theorem.

Theorem: If in an assignment problem we add a constant to every element of a row or column in the effectiveness matrix then an assignment that minimizes the total effectiveness in one matrix also minimizes the total effectiveness in the other matrix.

Example: A works manager has to allocate four different jobs to four workmen. Depending on the efficiency and the capacity of the individual the times taken by each differ as shown in the table 2. How should the tasks be assigned one job to a worker so as to minimize the total man-hours?

Table 2

Job	Worker			
	A	B	C	D
1	10	20	18	14
2	15	25	9	25
3	30	19	17	12
4	19	24	20	10

Solution: The following steps are followed to find an optimal solution.

STEP 1: Consider each row. Select the minimum element in each row. Subtract this smallest element from all the elements in that row. This results in the table 3.

Table 3

Job	Worker			
	A	B	C	D
1	0	10	8	4
2	6	16	0	16
3	18	7	5	0
4	9	14	10	0

STEP 2: We subtract the minimum element in each column from all the elements in its column. Thus we obtain table 4

Table 4

Job	Worker			
	A	B	C	D
1	0	3	8	4
2	6	9	0	16
3	18	0	5	0
4	9	7	10	0

STEP 3: In this way we make sure that in the matrix each row and each column has atleast one zero element. Having obtained atleast one zero in each row and each column, we assign starting from first row.

In the first row, we have a zero in (1, A). Hence we assign job 1 to the worker A. This assignment is indicated by a square □. All other zeros in the column are crossed (X) to show that the other jobs cannot be assigned to worker A as he has already been assigned. In the above problem we do not have other zeros in the first column A.

Proceed to the second row. We have a zero in (2, C). Hence we assign the job 2 to worker C, indicating by a square □. Any other zero in this column is crossed (X).

Proceed to the third row. Here we have two zeros corresponding to (3, B) and (3, D). Since there is a tie for the job 3, go to the next row deferring the decision for the present. Proceeding to the fourth row, we have only one zero in (4, D). Hence we assign job 4 to worker D. Now the column D has a zero in the third row. Hence cross (3, D). All the assignments made in this way are as shown in table 5.

Table 5

Job	Worker			
	A	B	C	D
1	0 □	3	8	4
2	6	9	0 □	14
3	18	0 □	5	0
4	9	7	10	0 □

STEP 4: Now having assigned certain jobs to certain workers we proceed to the column 1. Since there is an assignment in this column, we proceed to the second column. There is only one zero in the cell (3, B); we assign the jobs 3 to worker B. Thus all the four jobs have been assigned to four workers. Thus we obtain the solution to the problem as shown in the table 6.

Table 6

Job	Worker			
	A	B	C	D
1	0 □	3	8	4
2	6	9	0 □	16
3	18	0 □	5	0
4	9	7	10	0 □

The assignments are

Job to Worker	
1	A
2	C
3	B
4	D

We summarize the above procedure as a set of following rules:

- Subtract the minimum element in each row from all the elements in its row to make sure that at least we get one zero in that row.
- Subtract the minimum element in each column from all the elements in its column in the above reduced matrix, to make sure that we get at least one zero in each column.
- Having obtained at least one zero in each row and atleast one zero in each column, examine rows successively until a row with exactly one unmarked zero is found and mark (\square) this zero, indicating that assignment is made there. Mark (X) all other zeros in the same column, to show that they cannot be used to make other assignments. Proceed in this way until all rows have been examined. If there is a tie among zeros defer the decision.
- Next consider columns, for single unmarked zero, mark them (\square) and mark (X) any other unmarked zero in their rows.
- Repeat (c) and (d) successively until one of the two occurs.
 - There are no zeros left unmarked.
 - The remaining unmarked zeros lie atleast two in each row and column. i.e., they occupy corners of a square.

If the outcome is (1), we have a maximal assignment. In the outcome (2) we use arbitrary assignments. This process may yield multiple solutions.

6.3.1 Multiple Solutions

Example 1 Given the following matrix, find the optimal assignment.

	1	2	3	4	5
1	5	0	3	2	6
2	0	0	5	4	7
3	0	3	0	4	0
4	0	1	0	3	0
5	6	5	0	0	0

Solution: Note that all the rows and columns have at least one zero.

Row 1 has a single zero in column 2. So make an assignment, delete (mark X) the second zero in column 2. This is shown in table 7. **0** denotes assignment

Table 7

	1	2	3	4	5
1	5	0	3	2	6
2	0	0	5	4	7
3	0x	3	0	4	0
4	0x	1	0	3	0
5	6	5	0x	0	0x

Row 2 has a single zero in the first column. So make an assignment and delete the remaining zeros in column 1 as shown in table 8.

Table 8

	1	2	3	4	5
1	5	0	3	2	6
2	0	0x	5	4	7
3	0x	3	0	4	0
4	0x	1	0	3	0
5	6	5	0	0	0

Row 3, 4 and 5 have more than a single zero. So we skip these rows and examine the columns. Column 3 has three zeros and so omit it. Column 4 has a single zero in row 5. So we make an assignment, deleting the remaining zeros in row 5. The result is as shown in table 9.

Table 9

	1	2	3	4	5
1	5	0	3	2	6
2	0	0x	5	4	7
3	0x	3	0	4	0
4	0x	1	0	3	0
5	6	5	0x	0	0x

Now we have two zeros in rows 3 and 4 in columns 3 and they occupy the corners of a square. An arbitrary assignment has to be made. If we make an assignment in (3, 3) and delete the remaining zero in row 3 and in column 3, this leaves one zero in the position (4, 5) and an assignment is made there. Thus we have a solution to the problem as in table 10.

Table 10

	1	2	3	4	5
1	5	0	3	2	6
2	0	0x	5	4	7
3					
4	0x	3	0	4	0x
5	0	1	0x	3	0
	6	5	0	0	0x

One more assignment (as a solution) is possible in this problem. (i.e.) we could have made an assignment at (3, 5) deleting other zero in the row 3 and zero in column 5 and making the last assignment at (4, 3). This is shown below in table 11.

Table 11

	1	2	3	4	5
1	5	0	3	2	6
2	0	0x	5	4	7
3					
4	0x	3	0x	4	0
5	0x	1	0	3	0x
	6	5	0x	0	0x

Remark: All the above markings can be done in a single matrix itself. We need not write the matrix repeatedly. This is done only to clarify the presentation.

6.4 Hungarian Algorithm

In the two examples above, the first one gave a solution leaving no zeros. It was a case of no ambiguity and in the second, we had more zeros and the tie was broken arbitrarily. Sometimes if we proceed in the steps explained above, we get a maximal assignment, which does not contain an assignment in every row or column. We are faced with a question of how to solve the problem. In such a case, the effectiveness matrix has to be modified, so that after a finite number of iterations an optimal assignment will be in sight. The following is the algorithm to solve a problem of this kind and this is known as Hungarian algorithm. The systematic procedure is explained in different steps and a problem is solved as an illustration.

STEP 1: Starting with a maximal assignment mark (\checkmark) all rows for which assignments have not been made.

STEP 2: Mark (\surd) columns not already marked which have zeros in the marked-rows.

STEP 3: Mark (\surd) rows not already marked which have assignments in the marked columns.

STEP 4: Repeat steps 2 and 3 until the chain of markings ends.

STEP 5: Draw lines through all unmarked rows and through all marked columns. (Check: If the above steps have been carried out correctly, there should be as many lines as there were assignments in the maximal assignment and we have at least one line passing through every zero.) This is a method of drawing minimum number of lines that will pass through all zeros. Thus all the zeros are covered.

STEP 6: Now examine the elements that do not have a line through them. Choose the smallest element and subtract it from all the elements the intersection or junction of two lines. Leave the remaining elements of the matrix unchanged.

STEP 7: Now proceed to make an assignment. If a solution is obtained with an assignment for every row, then this will be the optimal solution. Otherwise proceed to draw minimum number of lines to cover all zeros as explained in steps 1 to 5 and repeat iterations if needed.

Consider the following example.

Example 1

Solve the following assignment problem to minimize the total cost represented as elements in the matrix (cost in thousand rupees).

	Contractor			
Building	1	2	3	4
A	48	48	50	44
B	56	60	60	68
C	96	94	90	85
D	42	44	54	46

Solution:

STEP 1: Choose the least element in each row of the matrix and subtract the same from all the elements in each row so that each row contains at least one zero. Thus we have table 12.

Table 12

	Contractor			
Building	1	2	3	4
A	4	4	6	0
B	0	4	4	12
C	11	9	5	0
D	0	2	12	4

STEP 2: Choose the least element in each column and subtract the same from all the elements in that column to ensure that there is at least one zero in each column. Thus we have table 13.

Table 13

	Contractor			
Building	1	2	3	4
A	4	2	2	0

B	0	2	0x	12
C	11	7	1	0x
D	0x	0	8	4

STEP 3: We make the assignment in each row and column as explained previously. This results in table 1

Table 14

Building	Contractor			
	1	2	3	4
A	4	2	2	0
B	0	2	0x	12
C	11	7	1	0x
D	0x	0	8	4

Here we have only three assignments. But we must have four assignments. With this maximal assignment we have to draw the minimum number of lines to cover all the zeros. This is carried out as explained in steps 4 to 9. Refer table 15.

Table 15

Building	Contractor			
	1	2	3	4
A	4	2	2	0
B	0	2	0x	12
C	11	7	1	0x
D	0x	0	8	4

STEP 4: Mark (\checkmark) the unassigned row (row C).

STEP 5: Against the marked row C, look for any 0 element and mark that column (column 4).

STEP 6: Against the marked column 4, look for any assignment and mark that row (row A).

STEP 7: Repeat steps 6 and 7 until the chain of markings ends.

STEP 8: Draw lines through all unmarked rows (row B and row D) and through all marked columns (column 4). (Check: There should be only three lines to cover all the zeros.)

STEP 9: Select the minimum from the elements that do not have a line through them. In this example we have 1 as the minimum element, subtract the same from all the elements that do not have a line through them and add this smallest element at the intersection of two lines. Thus we have the matrix shown in table 16.

Table 16

Building	Contractor			
	1	2	3	4
A	3	1	1	0
B	0	2	0x	13
C	10	6	0	0x
D	0x	0	8	5

STEP 10: Go ahead with the assignment with the usual procedure. This is carried out in the table 16. Thus we have four assignments.

Building A is allotted to contractor 4
 Building B is allotted to contractor 1
 Building C is allotted to contractor 3
 Building D is allotted to contractor 2

Total cost is $44 + 56 + 90 + 44 = \text{Rs. } 234$ thousands.

Example: An airline that operates seven days a week has a timetable given below. Crews must have a minimum layover time of 6 hours between flights. Obtain the pairing of flights that minimizes layover time away from home. For any given pairing the crew will be based at the city that results in the smaller layover. For each pair also mention the city where the crew should be placed.

Flight No.	Karachi to	Islamabad
1	7.00 a.m.	9.00 a.m.
2	9.00 a.m.	11.00 a.m.
3	1.30 p.m.	3.30 p.m.
4	7.30 p.m.	9.30 p.m.

Flight No.	Islamabad to	Karachi
101	9.00 a.m.	11.00 a.m.
102	10.00 a.m.	12.00 Noon
103	3.30 p.m.	5.30 p.m.
104	8.00 p.m.	10.00 p.m.

Solution:

STEP 1: We prepare a matrix in which all the flights reaching Islamabad are paired with flights with No's 101, 102, 103 and 104. The elements in the matrix represent the time taken (hrs) by Karachi based crew in Islamabad. Refer table 17.

Flight No.	101	102	103	104
1	24	25	6.5	11
2	22	23	28.5	9
3	17.5	18.5	24	28.5
4	11.5	12.5	18	22.5

Explanation: The crew in the first flight No. 1 leaving Karachi arrives at Islamabad at 9.00 a.m. If the crew is to return by flight No. 101, it is not possible on the same day and it has to stay for 24 hours (layover time). Similarly to return by flight No. 102, 103 and 104, the same crew takes 25 hours, 6.5 hours, 11 hours respectively. In the same way we calculate the time spent by the crew in flights 2, 3 and 4 to pair with flights with No. 101, 102, 103 and 104. This is shown in Table 17.

STEP 2: We prepare a matrix in which all the flights reaching Karachi are paired with flights with numbers 1,2,3 and 4. The elements in the matrix indicate the time spent by Islamabad based crew in Karachi. This is shown in table 18.

Table 18

Flight No.	101	102	103	104
1	20	19	13.5	9
2	22	21	15.5	11
3	26.5	25.5	20	15.5
4	8.5	7.5	26	21.5

STEP 3: Comparing the corresponding elements of the two matrices (tables 17 and 18), we choose the minimum element and indicate the base at the top of the element (Karachi base-D, Islamabad base-C.). Thus we prepare the table 19. If the crew is placed in either city it is denoted by *.

Table 19

Flight No.	101	102	103	104
1	20 ^C	19 ^C	6.5 ^C	9 ^C
2	22*	21 ^C	15.5 ^C	9 ^D
3	17.5 ^D	18.5 ^D	20 ^C	15.5 ^C
4	8.5 ^C	7.5 ^C	18 ^D	21.5 ^C

STEP 4: We proceed with the usual steps of assignment problem. Thus we have the following tables 20 and 21.

Table 20

Flight No.	101	102	103	104
1	13.5	12.5	0	2.5
2	13	12	6.5	0
3	2	3	5	0
4	1	0	10.5	14

Table 21

Flight No.	101	102	103	104
1	12.5	12.5	0	25
2	12	12	6.5	0
3	1	3	5	0
4	0	0	10.5	14

We have the following assignments shown in table 22. The minimum number of lines (3), are drawn to cover all zero following Hungarian algorithm.

Table 22

Flight No.	101	102	103	104	
1	12.5	12.5	0	26	
2	11	11	5.5	0	√
3	0	2	3.5	0	√
4	0	0	10.5	15	√

STEP 5

Select the smallest element from those, which have no lines through them. In this case this is 1. Hence subtract the same from all the elements that do not have a line through them and add the same at the intersection of two lines. Thus we have the table 23.

Table 23

Flight No.	101	102	103	104
1	12.5	12.5	0	26
2	11	11	5.5	0
3	0	2	3.5	0
4	0	0	10.5	15

We assign rowwise and then columnwise. We have the table 24

Table 24

Flight No.	101	102	103	104
1	12.5	12.5	0	26
2	11	11	5.5	0
3	0	2	3.5	0x
4	0x	0	10.5	15

The result can be given as,

- Flight no. 1 is paired with 103 with base at Karachi.
- Flight no. 2 is paired with 104 with base at Karachi.
- Flight no. 3 is paired with 101 with base at Karachi.
- Flight no. 4 is paired with 102 with base at Islamabad.

6.5 Maximization in Assignment Model

The problem of maximization is carried out similar to the case of minimization making a slight modification. The required modification is to multiply all elements in the matrix by -1, based on the concept that minimizing the negative of a function is equivalent to maximize the original function. This case is illustrated in the following example.

Example: Six salesmen are to be allocated to six sales regions. The earning of each salesman at each region is given below. How can you find an allocation, so that the earnings will be maximum?

Region

Salesman	1	2	3	4	5	6
A	15	35	0	25	10	45
B	40	5	45	20	15	20
C	25	60	10	65	25	10
D	25	20	35	10	25	60
E	30	70	40	5	40	50
F	10	25	30	40	50	15

(Figure are in Rs. 1000)

Solution: In this problem the objective is to maximize the earnings of six salesmen sent to different regions. The first step is to multiply all the elements by (-1) and apply the method for minimization. So we have the starting table as shown in table 25.

Table 25

Salesman	Region					
	1	2	3	4	5	6
A	-15	-35	0	-25	-10	-45
B	-40	-5	-45	-20	-15	-20
C	-25	-60	-10	-65	-25	-10
D	-25	-20	-35	-10	-25	-60
E	-30	-70	-40	-5	-40	-50
F	-10	-25	-30	-40	-50	-15

The second step is to follow the procedure of subtracting the least element from each row and then in each column to ensure that there is atleast one zero in each row and in each column. This is presented in tables 26 and 27.

Table 26

Region

Salesman	1	2	3	4	5	6
A	30	10	45	20	35	0
B	5	40	5	25	30	25
C	40	5	55	0	40	55
D	35	40	25	50	35	0
E	40	0	30	65	30	20
F	40	25	20	10	0	35

Table 27

Region

Salesman	1	2	3	4	5	6
A	25	10	45	20	35	0
B	0	40	0	25	30	25
C	35	5	55	0	40	55
D	30	40	25	50	35	0
E	35	0	30	65	30	20
F	35	25	20	10	0	35

The third step is to assign salesmen to regions and test for optimality with the usual method as in table 28.

Table 28

Region

Salesman	1	2	3	4	5	6
A	25	10	45	20	35	0
B	0	40	0x	25	30	25
C	35	5	55	0	40	55
D	30	40	25	50	35	0x
E	35	0	30	65	30	20
F	35	25	20	10	0	35

Since we have six assignments, we have an optimal solution as given below in tables 29 to 31.

Salesman A is assigned to region 1,

B to region 3,

C to region 4,

D to region 6,

E to region 2 and

F to region 5

Total earnings are $15 + 45 + 65 + 60 + 70 + 50 = \text{Rs. } 3.5$ (in thousands)

First iteration

Table 29

Salesman	Region					
	1	2	3	4	5	6
A	15	0x	35	10	25	0x
B	0	40	0x	25	30	35
C	35	5	55	0	40	65
D	20	30	15	40	25	0
E	35	0	30	65	30	30
F	35	25	20	10	0	45

Second iteration

Table 30

Salesman	Region					
	1	2	3	4	5	6
A	5	0x	25	0x	15	0x
B	0	50	0x	25	30	45
C	35	15	55	0	40	75
D	10	30	5	30	15	0
E	25	0	30	55	20	30
F	35	35	20	10	0	55

Third iteration

Table 31

Salesman	Region					
	1	2	3	4	5	6
A	0	0x	20	5	10	0x
B	0x	55	0	30	30	45
C	30	15	50	0	35	75
D	5	30	0x	30	10	0
E	20	0	15	55	15	30
F	35	40	20	15	0	60

6.6 Impossible Assignment

Sometimes in an assignment model we are not able to assign some jobs to some persons. For example if machines are to be allocated to locations and if a machine cannot be accommodated in a particular location, then it is an impossible assignment. To solve the problem in such situations we attach a very highly prohibited (say ∞) cost to the cell in the matrix so that there is absolutely no chance to get the assignment with infinite cost in the optimal solution.

Example

The processing times in hours for the jobs when allocated to the different machines are indicated below. When a job is not possible to be made in a particular manner, it is indicated as '-'

Jobs	Machine				
	I	II	III	IV	V
A	3	-	8	-	8
B	4	7	15	18	8
C	8	12	-	-	12
D	5	5	8	3	6
E	10	12	15	10	-

Allocate the machines for the jobs so that the total processing time is minimum.

Solution:

We have the impossible assignments marked as ∞ . We introduce deliberately a high prohibitive time (say ∞) in those places and proceed with the usual steps of solution procedure for assignment problem. Thus we have the table 32.

Table 32

Jobs	Machine				
	I	II	III	IV	V
A	3	∞	8	∞	8
B	4	7	15	18	8
C	8	12	∞	∞	12
D	5	5	8	3	6
E	10	12	15	10	∞

Reducing the matrix in rows and columns so as to have atleast one zero in each row and in each column, we have the following tables 33 and 34

Table 33

Jobs	Machine				
	I	II	III	IV	V
A	0	∞	8	∞	5
B	0	3	11	14	4
C	0	4	∞	∞	4
D	2	2	5	0	3
E	0	2	5	0	∞

Table 34

Jobs	Machine				
	I	II	III	IV	V
A	0	∞	0	∞	2
B	0	1	6	14	1
C	0	2	∞	∞	1
D	2	0	0	0	0
E	0	0	0	0	∞

Next we proceed to assign jobs to machines as in table 35.

Table 35

Jobs	Machine				
	I	II	III	IV	V
A	0x	∞	0	∞	2
B	0	1	6	14	1
C	0x	2	∞	∞	1
D	2	0x	0x	0x	0
E	0x	0	0x	0x	∞

From 35 we see that there are only four assignments but we should have five assignments.

We now proceed with drawing minimum number of lines to cover all zeros as in table 36.

Table 36

Jobs	Machine				
	I	II	III	IV	V
A	0x	∞	0	∞	2
B	0	1	6	14	1
C	0x	2	∞	∞	1
D	2	0x	0x	0x	0
E	0x	0x	0x	0	∞

Now subtract the least element from the elements that do not have a line through them. In this case this element is 1. We subtract it from all elements, which do not have a line through them and add the same at the intersection of two lines. Proceeding in this way we have the table 37.

Table 37

Jobs	Machine				
	I	II	III	IV	V
A	1	∞	0	∞	2
B	0	0x	5	13	0x
C	0x	1	∞	∞	0
D	3	0	0x	0x	0
E	1	0x	0x	0	∞

(Note: Since we have number of zeros occupying corner of a square, we have multiple solutions).

Job A is assigned to machine III, B to machine I, C to machine V, D to machine II, E to machine IV.

6.7 Exercise

1. Three jobs A, B, C are to be assigned to three machines X, Y, Z. The processing costs (in Rs.) are as given in the matrix shown below. Find the allocation, which will minimize the overall processing cost.

Machine			
jobs	A	B	C
X	19	28	31
Y	11	17	16
Z	12	15	13

2. A college department chairman has the problem of providing teachers for all courses offered by his department at the highest possible level of educational 'quality'. He has one professor, two associate professors, and one teaching assistant (TA) available. Four courses must be offered and, after appropriate introspection and evaluation he has arrived at the following relative ratings (100 = basic rating) regarding the ability of each instructor to teach the four courses, respectively.

Courses				
	1	2	3	4
Prof. 1	60	40	60	70
Prof. 2	20	60	50	70
Prof. 3	20	30	40	60
T.A.	30	10	30	40

How should he assign his staff to the courses to maximize educational quality in his department?

3. (a) Explain the Hungarian method of solving an assignment problem for minimization.
 (b) Solve the following assignment problem for minimization with cost (in rupees) matrix as:

Machine					
Jobs	A	B	C	D	E
1	4	10	3	4	8
2	7	2	6	7	7
3	10	5	8	11	4
4	3	6	5	3	2
5	10	7	3	5	7

4. State the linear programming formulation of an assignment problem.

Four Jobs can be processed on four different machines, one job on one machine. Resulting profits vary with assignments. They are given below.

Machine				
Jobs	A	B	C	D
I	42	35	28	21
II	30	25	20	15
III	30	2	20	15
IV	24	20	16	12

Find the optimum assignment of jobs to machines and the corresponding profit.

5. Five men are available to do five different jobs. From past records the time in hours that each man takes for each job is known and is given below.

Jobs					
Men	I	II	III	IV	V
A	3	10	3	8	2
B	7	9	8	7	2
C	5	7	6	4	2
D	5	3	8	4	2
E	6	4	10	6	2

Find the assignment of men to jobs that will minimize the total time taken.

6. Pearl Corporation has four plants each of which can manufacture any one of four products. Production costs differ from one plant to another as do sales revenue. Given the revenue and cost data below, obtain which product each plant should produce to minimize the profit.

Plant	Sales Revenue				Production Cost			
	Product				Product			
	1	2	3	4	1	2	3	4
A	50	68	49	62	49	60	45	61
B	60	70	51	74	55	63	45	69
C	55	67	53	70	52	62	49	58
D	58	65	54	69	55	64	48	66

7. Five different machines can process any of the five required jobs with different profits resulting from each assignment.

Machine					
Job	A	B	C	D	E
1	130	137	140	128	140
2	140	124	127	121	136
3	140	132	133	-	135
4	-	138	140	136	136
5	129	-	141	134	139

Find the maximum profit possible through optimum assignments.

8. A construction company has five bulldozers at different locations and one bulldozer is required at three different constructions sites. If the transportation cost are as shown, determine the optimum shipping schedule.

Location	Shipping cost ('000 Rs)		
	Construction site		
	A	B	C
1	20	30	40
2	70	60	40
3	30	50	80
4	40	60	50
5	40	60	30

9. A manager has the problem of assigning four new machines to three production facilities. The respective profits derived are as shown. If only one machine is assigned to a production facility determine the optimal assignment.

Machine	Profits ('000 Rs)		
	Production facility		
	1	2	3
A	10	10	14
B	10	11	13
C	12	10	10
D	13	12	11

10. Solve the following unbalanced assignment problem of minimizing total time for doing all the jobs.

Operator	Jobs				
	1	2	3	4	5
1	6	2	5	2	6
2	2	5	8	7	7
3	7	8	6	9	8
4	6	2	3	4	5
5	9	3	8	9	7
6	4	7	4	6	8

7 Queuing Theory

7.1 Introduction

It is a common phenomenon in everyday life to see a large number of persons waiting in front of a booking counter in a railway station or in a theatre or in a ration shop to have some service carried out. This formation of queue occurs whenever the present demand for a service exceeds the present capacity to provide the necessary government, industry, schools, hospitals, etc.

A decision regarding the amount of capacity to provide must be made frequently in industry and other places. It is difficult to predict about an arrival and the type of service required. If we provide too much service, it would involve unnecessary excessive costs. On the otherhand, if we do not provide enough service capacity, this will result in a long waiting line, which proves costly. So we are interested in reaching an economic balance between the cost of service and the cost associated with waiting for the service. Queuing theory or waiting line theory provides vital information required for such a decision. For describing a waiting line situation queuing theory provides a number of alternative mathematical models.

The basic queuing system consists of two major components as shown in figure 1. Customers arriving at a queuing system wait in queue to get some service, or if the system is idle or empty, the arriving customer may be serviced immediately. Once the service is over the customer leaves the system.

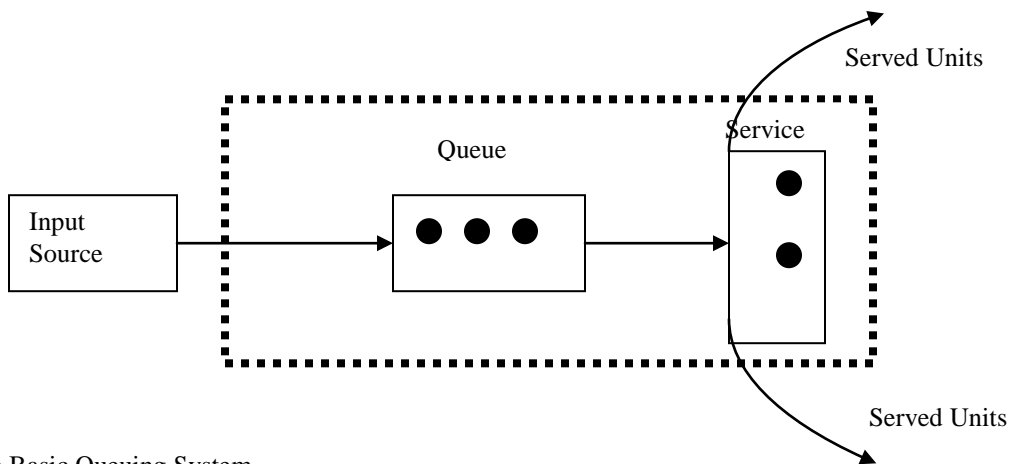

The Basic Queuing System

7.2 Definitions of some important terms in Queuing Model

7.2.1 Customer

The arriving unit that requires some service to be provided is called the customer. The customer may represent people, machines, etc.

7.2.2 Server

A server is one who provides the arriving customer the necessary service. It may be persons in the counter or machines, etc.

7.2.3 Waiting Line or Queue

The queue represents the number of customers waiting to be served. Normally the queue does not include the customer being served.

7.2.4 Service Channel

This refers to the type of service provided. If we have one serving unit only, we have a single channel model or single server model. If service involves more than one server, we have a multi-channel server model. We use the symbol k to denote the number of service channels.

7.2.5 Arrival Rate

This is the rate at which customers arrive to be serviced. This arrival rate may not be constant. Hence it is treated as a random variable for which a certain probability distribution is to be assumed. The assumption regarding the distribution of this value has an effect upon the mathematical model. It is observed in general that in queuing theory arrival rate is randomly distributed according to the Poisson distribution. The mean value of the arrival rate is denoted by λ (lambda); the unit is usually customers/time period. There are queues with other probability distributions also.

7.2.6 Service Rate

This is the rate at which the service is offered to the customers. This can be done by a single server or sometimes by multiple servers, but this service rate refers to service offered by a single service channel. This rate is also a random variable as the service to one customer may be different from the other. Hence it is also assumed to follow in general, the Poisson distribution. The mean value of the service rate is μ (mu); the unit is customers/time period. The distribution of this rate plays a role in the mathematical model. Other distributions are also assumed.

7.2.7 Infinite Queue

If the customers who arrive and form the queue are from a large population (eg. people crowding at a cinema theatre, book in counter etc.) then the queue is referred to as infinite queuing model. This assumption also has great influence in the mathematical formulation and its solution.

7.2.8 Finite Queue

If the customers arrive from a small number of population say less than 30, then this is treated as a finite queue. This value also has an effect in the mathematical model formulation and its solution.

7.2.9 Priority

This refers to the method of deciding which customer will be served next. The most common assumption is first come, first served (first in, first out). This assumption has also an effect in the derivation of formulae used for analysis.

7.2.10 Expected Number in Queue

This is the average or mean number of customers waiting to be serviced. This is denoted by L_q .

7.2.11 Expected Number in System

This is the average number of customers either waiting in the line and/or being serviced, denoted by L .

7.2.12 Expected Time in Queue

This is the expected or mean time a customer waiting in line and/or being serviced, denoted by W_q .

7.2.13 Expected Number in Nonempty Queue

This is the average or expected number of customers waiting in the line excluding those times when the queue is empty. This figure can be arrived by counting and averaging only nonzero values. It would be equivalent to L . This expected number in the nonempty queue is denoted by L_n .

7.2.14 Expected Waiting Time For Nonempty Queue

: This is the expected time a customer waits in line if he has to wait at all. This value is the average of waiting times for all customers entering the queue when the serving counter is filled. Customers entering the channel is empty needing not have to wait (zero waiting time) and these values are not taken into account in arriving at the average. W_n denotes this value.

7.2.15 System Utilization or Traffic Intensity

This is the ratio between arrival and service rate denoted by ρ given by (λ / μ) .

7.3 Single Channel Infinite-Population Model

We assume in queueing theory that the arrivals or services be random and independent of all other conditions. This will lead to the condition that the distribution of arrival rate can be shown to be Poisson. The mean is independent of time and not affected by a number of customers in waiting line, previously serviced etc. This means that the probability of an arrival during any time period Δt is constant and equal to $\lambda \Delta t$. Similarly we have the conditional probability of a service executed is also given as $\lambda \Delta t$ given that there is a customer to be serviced. We will assume that the time period Δt is so small that higher orders of Δt , are neglected.

Let n be the number of units in the system and $P_n(t)$ be the probability of n units in the system at time t . The derivation of expressions is done in three steps.

Step 1: Find $P_n(t)$ in terms of λ and μ .

Step 2: Using this expression find the expected number of units in the system in terms of λ and μ .

Step 3: Using the results of the previous step, derive the expressions for system time etc.

The probability of n units in the system can be found by adding the probabilities of all the ways this event could occur. Let us take all the cases ending up with n units at time $(t + \Delta t)$

Case	No. of units at time t	No. of arrivals	No. of services	No. of units at time $(t + \Delta t)$
1	n	0	0	n
2	$n + 1$	0	1	n
3	$n - 1$	1	0	n

The probability of a service rate is $\mu \Delta t$ and that of an arrival rate is $\lambda \Delta t$ and $(\Delta t)^2 \rightarrow 0$

Since the probabilities are independent we use the multiplication theorem in probability

$$\text{Probability of case 1} = \left(\begin{array}{c} \text{Probability} \\ \text{of } n \text{ at time } t \end{array} \right) \times \left(\begin{array}{c} \text{Probability} \\ \text{of no arrivals} \end{array} \right) \times \left(\begin{array}{c} \text{Probability} \\ \text{of no service} \end{array} \right)$$

$$\begin{aligned}
&= [P_n(t)](1-\lambda\Delta t)(1-\mu\Delta t) \\
&= P_n(t) \left[1-\lambda\Delta t-\mu\Delta t+\lambda\mu(\Delta t)^2 \right] \\
&= P_{n+1}(t)(\mu\Delta t)
\end{aligned}$$

$$\text{Probability of case 2} = \left(\begin{array}{c} \text{Probability} \\ \text{of } n+1 \text{ at time } t \end{array} \right) \times \left(\begin{array}{c} \text{Probability} \\ \text{of no arrivals} \end{array} \right) \times \left(\begin{array}{c} \text{Probability} \\ \text{of one service} \end{array} \right)$$

$$\begin{aligned}
&= [P_{n+1}(t)][1-\lambda\Delta t][\mu\Delta t] \\
&= P_{n+1}(t) \left[\mu\Delta t-\mu\lambda(\Delta t)^2 \right] \\
&= P_{n+1}(t)(\mu\Delta t)
\end{aligned}$$

$$\text{Probability of case 3} = \left(\begin{array}{c} \text{Probability} \\ \text{of } (n-1) \text{ at time } t \end{array} \right) \times \left(\begin{array}{c} \text{Probability} \\ \text{of one arrivals} \end{array} \right) \times \left(\begin{array}{c} \text{Probability} \\ \text{of no service} \end{array} \right)$$

$$\begin{aligned}
&= P_{n-1}(t) (\lambda\Delta t) (1-\mu\Delta t) \\
&= P_{n-1}(t) (\lambda\Delta t)
\end{aligned}$$

All other possibilities or combinations except the above three cases will be involving the term $(\Delta t)^2$ which tends to zero. As an example, let us take a combination to have n units on hand at time t then have one arrival and one service being completed during Δt . Then

$$\begin{aligned}
\text{Probability of this case} &= P_n(t + \Delta t) = P_n(t)(\mu\Delta t) (\lambda\Delta t) \\
&= P_n(t) \mu\lambda (\Delta t)^2 = 0
\end{aligned}$$

Now adding all three cases we find $P_n(t + \Delta t)$ given by

$$\begin{aligned}
P_n(t + \Delta t) &= P_n(t + \Delta t) = P_n(t)(1 - \lambda\Delta t - \mu\Delta t) \\
&\quad + P_{n+1}(t)(\mu\Delta t) + P_{n-1}(t)(\lambda\Delta t)
\end{aligned}$$

This will lead to the result what we wanted in Step 1 i.e. to find $P_n(t)$ in terms of λ and μ . Recall the assumption that the mean arrival rate and service rate are independent of time. This implies that the probability of n units in the system at time t is the same as at time $(t + \Delta t)$. Thus $P_n(t) = P_n(t + \Delta t)$. Use this in the above equation,

$$P_n(t) = P_n(t)(1 - \lambda\Delta t - \mu\Delta t) + P_{n+1}(t)(\mu\Delta t) + P_{n-1}(t)(\lambda\Delta t)$$

Solving for $P_{n+1}(t)$, we get

$$P_{n+1}(t)\mu\Delta t = P_n(t)\Delta t(\lambda + \mu) - P_{n-1}(t)\lambda\Delta t$$

$$P_{n+1}(t) = P_n(t) \frac{\lambda + \mu}{\mu} - P_{n-1}(t) \frac{\lambda}{\mu}$$

The expression gives the probability of $(n+1)$ units as a function of the last two stages n and $n - 1$. Still we need to find a general expression for $P_n(t)$ which can be determined in the following manner.

First find $P_1(t)$ in terms of $P_0(t)$ and λ, μ .

Consider the two possible cases for nobody in the system at time $(t + \Delta t)$ i.e. $P_0(t + \Delta t)$. They are;

Case (1) none at time t , no arrivals, no service.

Case (2) one at time t , no arrivals, one service.

For the above two cases we have the probabilities.

$$\text{Case (1): } P_0(t) (1 - \lambda\Delta t)(1)$$

Note that if no units were in the system, the probability of no service would be 1,

$$\text{Case 2: } P_1(t)(1 - \lambda\Delta t)(\mu\Delta t)$$

$$P_0(t + \Delta t) = \text{case 1 and case 2}$$

$$\begin{aligned} &= P_0(t)(1 - \lambda\Delta t)(1) + P_1(t - \lambda\Delta t)\mu\Delta t \\ &= P_0(t) - P_0(t)\lambda\Delta t + P_1(t)\mu\Delta t + P_1(t)\lambda\mu(\Delta t)^2 \\ &= P_0(t) - P_0(t)\lambda\Delta t + P_1(t)\mu\Delta t \text{ as } (\Delta t)^2 \rightarrow 0 \end{aligned}$$

We know that

$$\begin{aligned} P_0(t + \Delta t) &= P_0(t) \\ P_0(t) - P_0(t)\lambda\Delta t + P_1(t)\mu\Delta t &= P_0(t) \end{aligned}$$

Solving for $P_1(t)$, we get

$$\begin{aligned} P_1(t)\mu\Delta t &= P_0(t) + P_0(t)\lambda\Delta t \\ P_1(t) &= P_0(t) \frac{\lambda}{\mu} \end{aligned}$$

From the above step, we can develop an expression for $P_n(t)$ in terms of P_0 , λ and μ . Omitting the time notation due to the independence assumption

$$P_0(t) = P_0 \text{ (any time } t)$$

We write $P_0(t) = P_0$

$$P_1 = P_0 \frac{\lambda}{\mu}$$

$$P_2 = P_1 \frac{\lambda+\mu}{\mu} - P_0 \frac{\lambda}{\mu}$$

$$= P_n \frac{\lambda+\mu}{\mu} - P_{n-1} \frac{\lambda}{\mu}$$

from P_{n+1}

But $P_1 = P_0 \frac{\lambda}{\mu}$

$$P_2 = P_0 \left(\frac{\lambda}{\mu} \right) \left(\frac{\lambda+\mu}{\mu} \right) - P_0 \frac{\lambda}{\mu}$$

$$= P_0 \left(\frac{\lambda}{\mu} \right) \left(\frac{\lambda+\mu-1}{\mu} \right)$$

$$= P_0 \left(\frac{\lambda}{\mu} \right) \left(\frac{\lambda+\mu-\mu}{\mu} \right)$$

$$= P_0 \left(\frac{\lambda}{\mu} \right) \left(\frac{\lambda}{\mu} \right)$$

$$= P_0 \left(\frac{\lambda}{\mu} \right)^2$$

Similarly we have

$$P_3 = P_0 \left(\frac{\lambda}{\mu} \right)^3, P_4 = P_0 \left(\frac{\lambda}{\mu} \right)^4, P_5 = P_0 \left(\frac{\lambda}{\mu} \right)^5$$

In general we have

$$P_n = P_0 \left(\frac{\lambda}{\mu} \right)^n$$

The above equation gives P_n in terms of P_0 , λ and μ . Finally we have to find an expression for P_0 in terms of λ and μ . We know that the probability of a busy system is the ratio of the arrival rate and service rate, λ/μ . Thus the probability of an empty or idle system is P_0 .

$$P_0 = 1 - \frac{\lambda}{\mu}$$

Since $P_n = P_0 \left(\frac{\lambda}{\mu} \right)^n$

We write $P_n = \left(1 - \frac{\lambda}{\mu} \right) \left(\frac{\lambda}{\mu} \right)^n$ With this we complete the step 1.

Now we proceed to step 2. The expected number of units in the system is found using the concept of expected value,

$$E(x) = \sum_{i=0}^{\infty} x_i P_i$$

$$\begin{aligned}
L &= \sum_{n=0}^{\infty} n P_n \\
L &= \sum n \left(1 - \frac{\lambda}{\mu}\right) \left(\frac{\lambda}{\mu}\right)^n \\
&= \left(1 - \frac{\lambda}{\mu}\right) \left[0 \left(\frac{\lambda}{\mu}\right)^0 + 1 \left(\frac{\lambda}{\mu}\right) + 2 \left(\frac{\lambda}{\mu}\right)^2 + 3 \left(\frac{\lambda}{\mu}\right)^3 + \dots \right] \\
&= \left(1 - \frac{\lambda}{\mu}\right) \left[0 + \left(\frac{\lambda}{\mu}\right) + 2 \left(\frac{\lambda}{\mu}\right)^2 + 3 \left(\frac{\lambda}{\mu}\right)^3 + \dots \right]
\end{aligned}$$

Let the expression in the parenthesis be $= x$. The expression in x , being a geometric series, can be evaluated in the following way. Multiply both sides by $\frac{\lambda}{\mu}$. Then we have

$$\begin{aligned}
x \frac{\lambda}{\mu} &= \left(\frac{\lambda}{\mu}\right)^2 + 2 \left(\frac{\lambda}{\mu}\right)^3 + 3 \left(\frac{\lambda}{\mu}\right)^4 + \dots \\
x - x \frac{\lambda}{\mu} &= \frac{\lambda}{\mu} + 2 \left(\frac{\lambda}{\mu}\right)^2 - \left(\frac{\lambda}{\mu}\right)^2 + 3 \left(\frac{\lambda}{\mu}\right)^2 - 2 \left(\frac{\lambda}{\mu}\right)^3 + \dots \\
&= \frac{\lambda}{\mu} + \left(\frac{\lambda}{\mu}\right)^2 + \left(\frac{\lambda}{\mu}\right)^3 + \dots \text{ As } \frac{\lambda}{\mu} < 1 \text{ or } \lambda < \mu,
\end{aligned}$$

We have an infinite geometric series, with common ratio less than 1. Adding 1 to each side, we have

$$x - x \frac{\lambda}{\mu} + 1 = 1 + \frac{\lambda}{\mu} + \left(\frac{\lambda}{\mu}\right)^2 \dots$$

The summation of the right side is $1 / \left(1 - \frac{\lambda}{\mu}\right)$

Solving for x we get

$$\begin{aligned}
x(1 - \lambda/\mu) + 1 &= 1 / (1 - \lambda/\mu) \\
x &= \frac{1}{(1 - \lambda/\mu)^2} - \frac{1}{1 - \lambda/\mu} = \frac{\lambda/\mu}{(1 - \lambda/\mu)^2}
\end{aligned}$$

Substitute the value of x in the expression for L . Then we get

$$L = \left(1 - \frac{\lambda}{\mu}\right) \frac{\lambda/\mu}{1 - (\lambda/\mu)^2} = \frac{\lambda/\mu}{1 - \lambda/\mu} = \frac{\lambda}{\mu - \lambda}$$

$$L = \frac{\lambda}{\mu - \lambda}$$

Step 3

We have to derive the other expression of L_q , W , W_q , L_n and W_n in terms of λ and μ . The derivations will be as follows:

The expected system time W is

$$= \frac{\text{expected number in system}}{\text{arrival rate}}$$

$$L/\lambda = \lambda/\lambda(\mu-\lambda) = 1/(\mu-\lambda)$$

The expected time in queue W_q is

$W_q = \text{expected time} - \text{time in serve}$

$$W - \frac{1}{\mu} = \frac{1}{\mu-\lambda} - \frac{1}{\mu}$$

$$= \frac{\lambda}{\mu(\mu-\lambda)}$$

The expected number in queue L_q is

$L_q = \text{expected number in system} - \text{expected number in service}$

$$= \frac{\lambda}{\mu-\lambda} - \frac{\lambda}{\mu} = \frac{\mu\lambda - \lambda(\mu-\lambda)}{\mu(\mu-\lambda)}$$

$$= \frac{\mu\lambda - \lambda\mu + \lambda^2}{\mu(\mu-\lambda)} = \frac{\lambda^2}{\mu(\mu-\lambda)}$$

In the above expression, the expected number in service is 1 time the probability that the service unit is busy or 1

The expected number in a non-empty queue L_n

$$L_n = \frac{\text{Expected number in queue}}{\text{Probability that the queue is not empty}}$$

But the probability of non-empty queue

$$= 1 - P_0$$

$$= 1 - 1(1 - \lambda/\mu)$$

$$= \lambda/\mu$$

$$L_n = \frac{\lambda^2}{\mu(\mu-\lambda)} / \lambda/\mu = \frac{\lambda}{\mu-\lambda}$$

The expected waiting time for a non-empty queue W_n is

$$W_n = \frac{\text{expected time in queue}}{\text{probability of waiting}}$$

$$= \frac{1}{\mu-\lambda}$$

In a single server queueing model, with assumptions of Poisson arrival and Poisson service rate, infinite queueing type of problem and $(\lambda/\mu) < 1$ the following is the summary of formula used for analysis. The assumption

of Poisson arrival and the service rate are also equivalent to the exponential inter-arrival time and exponential service time.

7.4 Results for Poisson Arrival and Exponential Service Time

- | | |
|---|--|
| 1. The probability of an empty system | $P_0 = 1 - \frac{\lambda}{\mu}$ |
| 2. The traffic intensity or system utilization, | $\rho = \lambda/\mu$ |
| 3. The probability on n customers in the system | $P_n = P_0 (\lambda/\mu)^n$ |
| 4. The expected number in the queue | $L_q = \frac{\lambda^2}{\mu(\mu-\lambda)}$ |
| 5. The expected number in the system, | $L = \lambda/\mu - \lambda$ |
| 6. The expected time in the queue | $W_q = \frac{\lambda}{\mu(\mu-\lambda)}$ |
| 7. The expected waiting time in the system | $W = \frac{1}{\mu-\lambda}$ |
| 8. The expected number in the nonempty queue, | $L_n = \frac{\lambda}{\mu-\lambda}$ |
| 9. The expected time in the queue for nonempty queue, W_n | $= \frac{1}{\mu-\lambda}$ |

10. The probability of waiting time more than or equal to t .

$$P(\text{waiting time} \geq t) = \int_t^{\infty} \left(1 - \frac{\lambda}{\mu}\right) \lambda e^{(\lambda-\mu)w} dw$$

11. The probability of waiting time in the system

$$P(\text{waiting time} \geq t) = \int_t^{\infty} (\mu - \lambda) e^{(\lambda-\mu)v} dv$$

Example

(a) A repairman is to be hired to repair machines which break down at an average rate of 6 per hour. The breakdowns follow Poisson distribution. The nonproductive time of a machine is considered to cost Rs. 20 per hour. Two repairman, Mr. X and Mr. Y have been interviewed for this purpose. Mr. X charges Rs. 10 per hour and he services machines at the rate of 8 per hour. Mr. Y demands Rs. 14 per hour and he services at an average rate of 12 per hour. Which repairman should be hired? (Assume 8 hours shift per day).

Solution:

$$\lambda = 6 \text{ per hour}$$

$$\text{Cost of idle machine hour} = \text{Rs. } 20$$

For Mr. X:

$\mu = 8$, Hourly charges = Rs. 10

Average number of units in the system

$$= \frac{\lambda}{\mu - \lambda} = \frac{6}{8 - 6} = \frac{6}{2} = 3$$

Machine hours lost in 8 hour shift = $3 \times 8 = 24$ machine hours

Total cost = hiring charges of repairman + cost of idle time
 $= 10 \times 8 + 24 \times 20 = 80 + 480 = \text{Rs. } 560$

For Mr. Y:

$\mu = 12$, Hourly charges = Rs. 14/-

Average number of units in the system

$$\frac{\lambda}{\mu - \lambda} = \frac{6}{12 - 6} = \frac{6}{6} = 1$$

Machine hours lost in 8 hours shift = $1 \times 8 = 8$

Total cost = $14 \times 8 + 20 \times 8 = 112 + 160 = \text{Rs. } 272$

Obviously Mr. Y should be hired.

Example

A fertilizer company distributes its products by trucks loaded at its only loading station. Both company trucks and contractor's trucks are used for this purpose. It was found that on an average every 5 minutes one truck arrived and the average loading time was 3 minutes. 40% of the trucks belong to the contractors. Making suitable assumptions determine.

- (1) The probability that a truck has to wait.
- (2) The waiting time of a truck that waits.
- (3) The expected waiting time of contractor's trucks per day.

Solution:

Following assumptions are made for solving the given queueing model:

- (1) The arrival rate is randomly distributed according to Poisson distribution.
 - (2) The mean value of the arrival rate is λ .
 - (3) The service time distribution is approximated by an exponential distribution and the rate of service is μ .
 - (4) The rate of service is greater than the rate of arrivals.
 - (5) The queue discipline is first-come-first-served.
 - (6) The place of loading the trucks is only one i.e., there is only one service channel.
 - (7) The number of trucks being served is infinite.
- (1) It is given that

$$\text{Average arrival rate} = \lambda = \frac{60}{5} = 12 / \text{hour}$$

$$\text{Average service rate} = \mu = \frac{60}{3} = 20 / \text{hour}$$

Probability that a truck has to wait is given by the probability of a busy system.

$$\text{i.e., } \rho = \frac{\lambda}{\mu} = \frac{12}{20} = 0.6$$

(2) The waiting time of a truck that waits is given by

$$W_s = \frac{1}{\mu - \lambda} = \frac{1}{20 - 12} = \frac{1}{8} \text{ Hour} = 7.5 \text{ minutes}$$

(3) It is given that 40% of the total trucks belong to the contractor. Hence the expected waiting time of contractor's trucks per day (assuming 24 hours shift).

= (no of trucks per day) x (contractor's percentage)
x (Expected waiting time of a truck).

$$\begin{aligned} &= 12 \times 24 \times \frac{40}{100} \times \frac{\lambda}{\mu(\mu - \lambda)} \\ &= 288 \times 0.4 \times \frac{12}{20(20 - 12)} = 288 \times 0.4 \times \frac{3}{5 \times 8} \\ &= 8.64 \text{ hours per day.} \end{aligned}$$

Example

In a Bank, every 15 minutes one customer arrives for cashing the cheque. The staff in the only payment counter takes 10 minutes for serving a customer on an average. State suitable assumptions and find.

- (1) The average queue length.
- (2) Increase in the arrival rate in order to justify for second counter (when the waiting time of a customer is atleast 15 minutes the management will increase one more counter).

Solution:

The assumptions are as in the previous example.

(i) Arrival rate, $\lambda = \frac{60}{15} = 4$ per hour

(ii) Service rate, $\mu = \frac{60}{10} = 6$ per hour

As $\lambda < \mu$ using $M / M / 1 / \infty$ queueing models, the average queue length is given by

$$L = \frac{\lambda^2}{\mu(\mu - \lambda)} = \frac{4 \times 4}{6(6 - 4)} = \frac{16}{6 \times 2} = 1.33 \text{ units}$$

- (iii) The average waiting time for the present system is

$$= \frac{\lambda}{\mu(\mu-\lambda)} = \frac{4}{6(6-4)} = \frac{4}{12} = \frac{1}{3} \text{ hrs} = 20 \text{ mts.}$$

Since the management will increase one more counter if the waiting time is atleast 15 minutes. The second counter is justified at the existing arrival rate.

Example

A duplicating machine maintained for office use is used and operated by people in the office who need to make copies, mostly by secretaries. Since the work to be copied varies in length (number of pages of the original) and copies required, the service rate is randomly distributed, but it does approximate a Poisson having a mean service rate of 10 jobs per hour. Generally the requirements for use are random over the entire 8 hour work day but arrive at a rate of 5 per hour. Several people have noted that a waiting line develops occasionally and have questioned the policy of maintaining only one unit. If the time of a secretary is valued at Rs. 3.50 per hour, make a analysis to determine

- (a) equipment utilization
- (b) the per cent time that an arrival has to wait
- (c) the average system time
- (d) the average cost due to waiting and operating the machine.

Solution:

The arrival rate λ is 5 per hour and the service rate μ is 10 per hour

- (a) The equipment utilization is

$$\rho = 5/10 = 0.50$$

Thus the equipment is in use 50 per cent of the time.

- (b) The per cent time an arrival has to wait is simply the per cent time that it is busy = 0.50
- (c) The average system time W

$$W = \frac{1}{\mu-\lambda} = \frac{1}{10-5} = \frac{1}{10-5} = \frac{1}{5} = 0.20 \text{ hours}$$

The average arrival will spend 0.20 hour in waiting and processing the job.

- (d) The average cost per day = number of jobs processed per day
x average cost period

Average cost per job = Average time per job x Rs. per hour

$$= W (\text{Rs. } 3.50/\text{hour}) = 0.20 (3.50)$$

Cost per day = 8(5) (0.20) (3.50) = Rs. 28 per day.

Example

At a public telephone booth in a post office arrivals are considered to be Poisson with an average inter-arrival time of 12 minutes. The length of a phone call may be assumed to be distributed exponentially with an average of 4 minutes.

- (a) What is the probability that a fresh arrival will not have to wait for the phone?
 (b) What is the probability that an arrival will have to wait more than 10 minutes before the phone is free?
 (c) What is the average length of queues that form time to time?

Solution:

It is given

$$\lambda = \frac{1}{12} = 0.085 \text{ per minute}$$

$$\mu = \frac{1}{4} = 0.25 \text{ per minute}$$

$$\frac{\lambda}{\mu} = 4/12 = 1/3 = 0.33 = \rho$$

Therefore, we have

- (a) The probability that a fresh arrival will not have to wait

$$\begin{aligned} &= 1 - P(w > 0) = 1 - \rho \\ &= 1 - 0.33 = 0.67 \end{aligned}$$

- (b) The probability for an arrival to have to wait for atleast 10 minutes is given by

$$\begin{aligned} &= \int_{10}^{\infty} (\lambda/\mu) (\mu - \lambda) e^{-(\mu-\lambda)t} dt \\ &= \int_{10}^{\infty} (0.33) (0.25 - 0.085) e^{-0.165t} dt \\ &= 0.5445 \left[\frac{e^{-0.165t}}{-0.165} \right]_{10}^{\infty} = 0.19 \end{aligned}$$

- (c) The average length of queues from time to time is given by

$$= \frac{\lambda}{\mu - \lambda} = \frac{0.085}{0.25 - 0.085} = 0.52$$

7.5 Exercise

1. a) A management has to decide which of the two repairmen X or Y to hire. The frequency of machine breakdown in the plant is known to follow the Poisson distribution at a rate of 1 machine per hour. Repairmen X charges Rs. 12 per hour. X is able to repair machines at a rate charges Rs. 12 per hour. X is able to repair machines at a rate of 1.8 machines per hour and Y is able to repair machines at a rate of 1.2 machines per hour. Assume there is infinite number of machines. What is the decision?

2. The belt snapping for conveyors in an open cast mine occur at the rate of 2 per shift. There is only one hot plate available for vulcanizing and it can vulcanize on an average rate of 5 belts per shift.
 - (i) What is the probability that one hot plate is readily available?
 - (ii) What is the average number in the system?
 - (iii) What is the total system time?

3. A repair shop attended by a single mechanic has an average of four customers an hour who bring small appliances for repair. The mechanic inspects them for defects and quite often can fix them right away or otherwise render a diagnosis. This takes him six minutes on the average. Arrivals are Poisson and service time has the exponential distribution.
 - (a) Find the proportion of time during which the shop is empty.
 - (b) Find the probability of finding atleast 1 customer in the shop.
 - (c) What is the average number of customers in the system?
 - (d) Find the average time, including services.

4. a) For each of the following, select the correct alternative:
 - (i) If on an average 10 customers join a queue in one hour and the average service time per customer is 6 minutes, then the average waiting time of a new arrival in M/M/1 queue is one hour.

(A) True (B) False (C) Cannot say
 - (ii) In an M/M/1 queue, the service system is busy 75% of the time and the inter-arrival time of customers is 4 minutes.

(A) 4.5 minutes (B) 4 minutes (C) 3 minutes (D) 2 minutes

- b) Problems arrive at a computing centre in Poisson fashion with a mean arrival rate of 25 per hour. The average computing job requires 2 minutes of terminal time. Calculate the following:
 - (i) Average number of problems waiting for the computer.
 - (ii) The per cent of times on arrival can walk right it without having to wait.

7.6 Multi-Channel Service Infinite Queue

If we have more than one service counter, each with mean service rate and with an arrival rate both following Poisson distribution, we have the following formulae in solving the problems. The derivation of these formulae is more complicated than that for a single server model

1. The probability of an empty or idle system,

$$P_0 = \frac{1}{\left[\sum_{n=0}^{n=k-1} \frac{1}{n!} \left(\frac{\lambda}{\mu} \right)^n \right] + \frac{1}{k!} \left(\frac{\lambda}{\mu} \right)^k \frac{k\mu}{k\mu - \lambda}}$$

2. The probability that an arrival has to wait (the probability that there are k or more units in the system) is

$$P_k = \frac{1}{k!} \left(\frac{\lambda}{\mu} \right)^k \frac{k\mu}{k\mu - \lambda} P_0$$

3. The expected number in the system

$$L = \frac{\lambda\mu(\lambda/\mu)^k}{(k-1)!(k\mu-\lambda)^2} P_0 + \frac{\lambda}{\mu}$$

4. The expected number in the queue is

$$L_q = \frac{\lambda\mu(\lambda/\mu)^k P_0}{(k-1)!(k\mu-\lambda)^2}$$

5. The expected time in the queue is

$$W_q = \frac{\mu(\lambda/\mu)^k P_0}{(k-1)!(k\mu-\lambda)^2}$$

6. The expected time in the system, is

$$W = \frac{\mu(\lambda/\mu)^k P_0}{(k-1)!(k\mu-\lambda)^2} + \frac{1}{\mu}$$

$$7. \quad P_n = \frac{1}{n!} \left(\frac{\lambda}{\mu} \right)^n P_0, \quad n = 0, 1, 2, \dots, k-1$$

$$P_n = \frac{1}{k!k^{n-k}} \left(\frac{\lambda}{\mu} \right)^n P_0, \quad n \geq k$$

Example

An insurance company has three claims adjusters in its branch office. People with claims against the company are found to arrive in a Poisson fashion, at an average rate of 20 per 8 hour day. The amount of time that an adjuster with a claimant is found to have an exponential distribution, with mean service time 40 minutes. Claimants are processed in the order of their appearance.

- How many hours a week an adjuster expected to spend with claimants?
- How much time, on the average, does a claimant spend in the branch office?

Solution:

$$\lambda = \frac{5}{2} \text{ per hour}$$

a)

$$\mu = \frac{3}{2} \text{ services per hour for each adjuster}$$

From formula

$$P_0 = \frac{1}{1 + \left(\frac{5}{3}\right) + \frac{1}{2} \times \left(\frac{5}{3}\right)^2 + \frac{1}{6} \times \left(\frac{5}{3}\right)^3 \times \frac{9/2}{4/2}} = \frac{24}{139}$$

The expected number of idle adjusters at any specified time is 3 when nobody is present, 2 when one is at the counter and 1 when two are being serviced with the probabilities of P_0 , P_1 and P_2 respectively.

The formula $P_n = \frac{1}{n!} \left(\frac{\lambda}{\mu}\right)^n P_0, n = 0, 1, 2, \dots, k-1$

$$P_1 = \frac{1}{1} \left(\frac{5}{3}\right)^1 \frac{24}{139} = \frac{40}{139}$$

$$P_2 = \frac{1}{2} \left(\frac{5}{3}\right)^2 \frac{24}{139} = \frac{100}{417}$$

Expected number of idle adjusters is

$$3P_0 + 2P_1 + P_2 = 3 \cdot \frac{24}{139} + 2 \cdot \frac{40}{139} = 1 \cdot \frac{100}{417} = \frac{4}{3}$$

Then the probability that at any time one adjuster will be idle is $(4/3) \times (1/3) = 4/9$. Expected weekly time spent by the adjuster is $(5/9) \times 40 = 22.2$ hours per week.

b) The average time an arrival spends in the system = system time

$$= \frac{\mu \left(\frac{\lambda}{\mu}\right)^k}{(k-1)!(k-\lambda)^2} P_0 + \frac{1}{\mu}$$

$$= \left[\frac{\frac{3 \left(\frac{5}{3}\right)^3}{2 \left(\frac{5}{3}\right)^2} \times \frac{24}{139} + \frac{2}{3}}{2! \left(\frac{9-5}{2}\right)^2} \right] \times 60 = 49 \text{ min utes}$$

7.6.1 Exercise

1. An office has to decide whether to go in for a larger duplicating machine in place of two small machines. The jobs arrive at the rate of 5 per hour. The data about the service rate and daily rental cost are given below.

What is the decision?

	Service Rate per Hour	Daily Rental Cost
Small (present) M/c	7	Rs. 50
Large M/c	11	Rs. 100

2. A certain queueing system has a poisson input with a mean arrival rate of two per hour. The service time distribution is exponential with a

mean of 0.4 hour. The marginal cost of providing each server is Rs. 4 per hour where it is estimated that the cost of each unit being idle is Rs. 100 per hour. Determine the number of servers that should be assigned to the system to minimize the expected total cost per hour.

- A telephone exchange has two long distance operators. The telephone company finds that during the peak period, long distance calls arrive in a poisson fashion at an average rate of 15 per hour. The service time is exponential with a mean of 5 minute per call, what is the probability that a subscriber will have to wait for his long distance call during peak period? What is the expected waiting time including service.

7.7 Multi-Channel Queue with Finite Population

In this case it is assumed that the number of channels k is more than 1, such that $1 < k \leq M$. The probability P_0 of an empty system is

$$P_0 = \frac{1}{\sum_{n=0}^{n=k-1} \left[\frac{M!}{(M-n)!n!} \left(\frac{\lambda}{\mu} \right)^n \right] + \sum_{n=k}^{n=M} \left[\frac{M!}{(M-n)!k!k^{n-k}} \left(\frac{\lambda}{\mu} \right)^n \right]}$$

The probability P_n of n customers in the system is

$$P_n = P_0 \frac{M!}{(M-n)!n!} \left(\frac{\lambda}{\mu} \right)^n \quad \text{where } 0 \leq n \leq k$$

$$P_n = P_0 \frac{M!}{(M-n)!k!k^{n-k}} \left(\frac{\lambda}{\mu} \right)^n \quad \text{where } k \leq n \leq M$$

Note that n cannot be greater than M . The expected number L of customers in the system is

$$L = \sum_{n=0}^{n=k-1} nP_n + \sum_{n=k}^{n=M} (n-k)P_n + k \left(1 - \sum_{n=0}^{n=k-1} P_n \right)$$

The expected number of customers L_q in the queue is

$$L_q = \sum_{n=k}^{n=M} (n-k)P_n$$

Example

A repairman services three machines. For each machine the time between service requirements is 8 hours following exponential distribution. The time of repair also has the same distribution with a mean of 2 hours. The downtime for a machine costs Rs. 100 per hour.

- the expected number of machines in operation
- the expected cost of downtime per day.

Solution:

a) First find λ and μ

$$\frac{1}{\lambda} = 8 \quad \lambda = 0.125$$

$$\frac{1}{\mu} = 2 \quad \mu = 0.5$$

$$P_0 = \frac{1}{\sum_{n=0}^{n=3} \left[\frac{3!}{(3-n)!} \left(\frac{0.125}{0.5} \right)^n \right]}$$

$$= \frac{1}{1+0.75+0.375+0.094}$$

$$= 1/2.22 = 0.45$$

The expected number of machines in system is

$$M - \frac{\mu}{\lambda} (1 - P_0)$$

$$= 3 - \frac{0.5}{0.125} (1 - 0.45)$$

$$= 3 - 4 \times 0.55$$

$$= 0.8$$

0.8 machines are not running. Hence expected number of machines running is 2.2

b) The expected downtime cost per day (8 hours)

$$= 8 \times \text{expected number} \times \text{cost}$$

$$= 8 \times 0.8 \times 100 = \text{Rs. } 640$$

8 Replacement Models

8.1 Why Replacement?

If any equipment or machine is used for a long period of time, due to wear and tear, the item tends to worsen. A remedial action to bring the item or equipment to the original level is desired. Then the need for replacement becomes necessary. This need may be caused by a loss of efficiency in a situation leading to economic decline. By efflux of time the parts of an item are being worn out and the cost of maintenance and operation is bound to increase year after year. The resale value of the item goes on diminishing with the passage of time. The depreciation of the original equipment is a factor, which is responsible not to favour replacement because the capital is being spread over a long time leading to a lower average cost. Thus there exists an economic trade-off between increasing and decreasing cost functions. We strike a balance between the two opposing costs with the aim of obtaining a minimum cost. The problem of replacement is to determine the appropriate time at which a remedial action should be taken which minimizes some measure of effectiveness. Another factor namely technical and / or economic obsolescence may force us for replacement.

In this segment we deal with the replacement of capital equipment that deteriorates with time, group replacement and staffing problems.

8.2 Replacement of items with gradual deterioration

As mentioned earlier the equipments, machineries and vehicles undergo wear and tear with the passage of time. The cost of operation and the maintenance are bound to increase year by year. A stage may be reached that the maintenance cost amounts prohibitively large that it is better and economical to replace the equipment with a new one. We also take into account the salvage value of the items in assessing the appropriate or opportune time to replace the item. We assume that the details regarding the costs of operation, maintenance and the salvage value of the item are already known. The problem can be analysed first without change in the value of the money and later with the value included.

If the interest rate for the money is zero the comparison can be made on an average cost basis. The total cost of the capital in owning the item and operating is accumulated for n years and this total is divided by n .

Since we have discrete values for the costs for various years, an analysis is done using the tabular method, which is simple one to use discontinuous data. There are also the classical optimization techniques using finite difference methods for discrete parameters and using the differential calculus for continuous data.

Now we take an example in which an automobile fleet owner has the following direct operation cost (Petrol and oil) and increased maintenance cost (repairs, replacement of parts etc). The initial cost of the vehicle is Rs. 70,000. The operation cost, the maintenance cost and the resale price are all given in table 1 for five years.

Table 1

Year of service	Annual operating cost (Rs.)	Annual maintenance cost (Rs.)	Resale value (Rs.)
1	10000	6000	40000
2	15000	8000	20000
3	20000	12000	15000
4	26000	16000	10000
5	32000	20000	10000

Table 2

1 At the end of year n	Costs in '000 Rupees						
	2 Annual operating cost (Rs.)	3 Annual maintenance cost (Rs.)	4 Total running cost (2+3) (Rs.)	5 Cumulative Running cost (Rs.)	6 Capital cost (Rs.)	7 Total cost (Rs.) (5+6)	8 Average annual cost (Rs.) (7/n)
1	10	6	16	16	30	46	46.00
2	15	8	23	39	50	89	44.50
3	20	12	32	71	55	126	42.00
4	26	16	42	113	60	173	43.52
5	32	20	52	165	60	225	45.00

Table 2 gives the details of the analysis to find the appropriate time to replace the vehicle. The cumulative running cost and capital (Value - Resale value) required for various years are tabulated and the average annual cost is calculated. The corresponding year at which this average annual cost is minimum is chosen to be the opportune time of replacement.

It is evident from the last column of table 2 that the average annual cost is least at the end of three years. (equal to 42,000). Hence this is the best time to purchase a new vehicle.

Example A mill owner finds from his past records the costs of running a machine whose purchase price is Rs. 6000 are as given below.

Year	1	2	3	4	5	6	7
Running cost (Rs.)	1000	1200	1400	1800	2300	2800	3400
Resale value (Rs.)	3000	1500	750	375	200	200	200

Determine at what age is a replacement due?

Solution: We prepare the following table 3 to find the solution.

1 At the end of year n	2 Cumulative running cost (Rs.)	3 Capital cost (Rs.)	4 Total cost (2 + 3) (Rs.)	5 Average annual cost (Rs.)
1	1000	3000	4000	4000
2	2200	4500	6700	3350
3	3600	5250	8850	2950
4	5400	5625	11025	2756
5	7700	5800	13500	2700
6	10500	5800	16300	2717
7	13900	5800	19700	2814

From the above 3 we conclude that the machine should be replaced at the end of the fifth year, indicated by the least average annual cost (Rs. 2700) in the last column.

Example The mill owner in the previous problem has now three machines, two of which are two years old and the third one year old. He is considering a new type of machine with 50% more capacity than one of the old ones at a unit price of Rs. 8000. He estimates the running costs and resale price for the new machine will be as follows.

Year	1	2	3	4	5	6	7
Running cost (Rs.)	1200	1500	1800	2400	3100	4000	5000
Resale Price (Rs.)	4000	2000	1000	500	300	300	300

Assuming that the loss of flexibility due to fewer machines is of no importance, and that he will continue to have sufficient work for three of the old machines, what should his policy be?

Solution: As in the previous problem we prepare a table 4 to find the average annual cost of the new type of machine.

Table 4

At the end of year	Cumulative running cost (Rs.)	Capital cost (Rs.)	Total cost (Rs.)	Average annual cost (Rs.)
1	1200	4000	5200	5200
2	2700	6000	8700	4350
3	4500	7000	11500	3833
4	6900	7500	14400	3600
5	10000	7700	17700	3540
6	14000	7700	21700	3617
7	19000	7700	26700	3814

From the above table 4 we observe that the average annual cost is least at the end of five years and it would be Rs. 3540 per machine. But the new machine can handle 50% more capacity than the old one. So in terms of the old, the new machine's annual cost is only Rs. (3540) $(2/3)$ = Rs. 2360. This amount is less than the average annual cost for the old machine, which is Rs. 2700. If we replace the old machine with the new one, it is enough to have two new machines in place of with the new one; it is enough to have two new machines in place of three old machines. On comparing the cost of 2 new machines (Rs. 7080) with that for 3 old machines (Rs 8100), it is clear that the policy should be that the old machines have to be replaced with the new one. Still we have to decide about the time when to purchase the new machines.

The new machines will be purchased when the cost for the next year of running the three old machines exceeds the average annual cost for two new types of machines. Examining the table 3 pertaining to the previous problem, we find, the total yearly cost of one small machine from the column 4. The successive difference will give the cost of running a machine for a particular year. For example, the total cost for 1 year is Rs. 4000. The total cost for 2 years is Rs. 6700. The difference of Rs. 2700 will be accounted as the cost of running a small machine during the second year. Similarly we have Rs. 2150, Rs. 2175, Rs. 2475 and Rs. 2800 as the cost of running the old machine in the third, fourth, fifth and sixth year respectively.

Now, with this information we calculate the total costs next year for the two smaller machines, which are two years old (entering the third year of service) and one smaller machine aged one year (and hence entering second year of service), which will be

$$2 \times 2150 + 2700 = \text{Rs. } 7000$$

This is less than the average annual cost of two new machines, which is Rs. 7080. So the policy is not to replace right now. If we wait for the subsequent years, the total cost of running the old machines will be Rs. 6500, Rs. 7125 and Rs. 8025 etc., for years 2, 3 and 4 etc. This indicates that the cost of running the old machine exceeds the average annual cost (Rs. 7000) of the two new machines after 2 years from now. Hence the best time to purchase the new type machine will be after 2 years from now.

8.2.1 Exercise

- The cost of a machine is Rs. 6100 and its scrap value is only Rs. 100/-. The maintenance costs are found from experience to be.

Year	1	2	3	4	5	6	7	8
Maintenance cost (Rs.)	100	250	400	600	900	1250	1600	2000

When should the machine be replaced?

- A machine costs Rs. 8000. Annual operating costs are Rs. 1000 for the first year, and then increase by Rs. 500 every year. Resale prices are Rs. 4000 for the first year and then decrease by Rs. 500 every year. Determine at which age it is profitable to replace the machine.
- A machine owner finds from his past experience that the maintenance costs are Rs. 200 for the first year and then increase by Rs. 200 every year. The costs of the machine type A Rs. 9000. Determine the best age at which to replace the machine. If the optimum replacement is followed what will be the average yearly cost of owning and operating the machine? Machine type B costs Rs. 10000/-. Annual operating costs are Rs. 400 for the first year and then increase by Rs. 800/- every year. The machine owner has now the machine type A, which is one year old. Should it be replaced with B type and if so, when?
- Explain briefly the difference in replacement policies of items, which deteriorate gradually and items, which fail completely. A machine shop has a press, which is to be replaced as it wears out. A new press is to be installed now. Further an optimum replacement plan is to be found for next 7 years after which the press is no longer required. The following data is given below.

Year	1	2	3	4	5	6	7
Cost of installation (Rs.)	200	210	220	240	260	290	320
Salvage value (Rs.)	100	30	30	20	15	10	0
Operating cost (Rs.)	60	80	100	120	150	180	230

Find an optimum replacement policy and the corresponding minimum cost.

8.3 Items Deteriorating with value of money

In the previous section we did not take the interest for the money invested, the running costs and resale value. If the effect of time value of money is to be taken into account, the analysis must be based on an equivalent cost. This is done with the present value or present worth analysis.

For example, suppose the interest rate is given as 10% and Rs. 100 today would amount to Rs. 110 after a year's time. In other words the expenditure of Rs. 110 in year's time is equivalent to Rs. 100 today. Likewise one

rupee a year from now is equivalent to $(1.1)^{-1}$ rupees today and one-rupee in 'n' years from now is equivalent to $(1.1)^{-n}$ rupees today. This quantity $(1.1)^{-n}$ is called the present value or present worth of one rupee spent 'n' years from now.

We can establish an algebraic formula for the present worth value.

Let M = purchase price of an item.

R_n = running cost in year n .

r = rate of interest

The present worth of a rupee to be spent after a year is denoted by v and given by

$$v = 1/(1 + r)$$

v is called the discount rate. Let the item be replaced after n years, and that the expenditure can be considered to take place at the beginning of each year. Then the present worth of expenditure denoted by

$$P(n) = M + R_1 + vR_2 + v^2R_3 + \dots + v^{n-1}R_n$$

We note that $P(n)$ increases as n increases.

The present worth of expenditure incurred for n years including the capital cost is obtained from a money lending institution and we repay the loan by fixed annual installments throughout the life of the machine. The present worth of this fixed annual installment x for n years is

$$= x + vx + v^2x + \dots + v^{n-1}x$$

$$= x(1 + v + v^2 + \dots + v^{n-1})$$

$$P(n) = x \frac{1 - v^n}{1 - v} \text{ (using the formula for a geometric series)}$$

Since this is the sum repaid, we equate the present worth of expenditure to the present worth of repayment. Then,

$$x = \frac{1 - v}{1 - v^n} P(n).$$

So, the best period at which to replace the machine is the period n which minimizes x . Since $(1 - v)$ is constant, it is enough if we minimize $P(n)/(1 - v^n)$. The best period at which to replace the machine is the period n which minimizes $P(n) / (1 - v^n) = F(n)$ (say).

The value of n is not continuous but discrete and hence we are not in a position to employ differentiation to find the optimum period.

We can assume $n = 1, 2, 3$ etc., find $P(n)$ for different years and calculate using the formula for x above. Choose n which minimizes x . We shall illustrate this idea with an example.

Example The initial cost of an item is Rs. 15000 and maintenance or running cost for different years is given below.

Year	1	2	3	4	5	6	7
Running cost Rs.	2500	3000	4000	5000	6500	8000	10000

What is the replacement policy to be adopted if the capital is worth 10% and no salvage value.

Solution We know that

$$P(n) = M + R_1 + vR_2 + \dots + v^{n-1}R_n$$

Use this equation for $n = 1, 2, 3, \dots$

$$M = \text{Rs. } 15000$$

$$v = \frac{1}{1 + 0.1} = 0.909$$

R_1 to R_7 are as given in the problem. The best time to replace the item is n which is governed by $x = P(n) (1 - v) / (1 - v^n)$.

We use a tabular method to present the details for analysis in table 6.

Table 6

Year n	Running cost, $R_n(\text{Rs.})$	v^{n-1} (PWF)	$v^{n-1} R_n$	$P(n)$	$P(n) (1-v)/(1-v^n)$
1	2500	1.000	2500	17500	17500
2	3000	0.909	2727	20227	10595
3	4000	0.826	3304	23531	8602
4	5000	0.751	3755	27286	7826
5	6500	0.683	4440	31726	7609
6	8000	0.621	4968	36694	7660

We see from table 6 the value of the fixed annual installment given by the last column is minimum at year 5. So it is optimal to replace the machine after five years.

Example A manufacturer is offered two machines A and B . A is priced at Rs. 10000 and running costs are Rs. 1600 for each of the first five years, increasing by Rs. 400 per year in the sixth and subsequent years. Machine B which has the same capacity as A , costs Rs. 5000 but will have running costs of Rs. 2400 per year for six years increasing by Rs. 400 per year, there after. If the capital is worth 10% per year which machine should be purchased?

Solution: We prepare two tables 7 and 8 for machine A and for machine B respectively as shown.

Table 7

Machine A

Year n	Running cost, $R_n(\text{Rs.})$	v^{n-1} (PWF)	$v^{n-1} R_n$	$P(n)$	$P(n) (1-v)/(1-v^n)$
1	1600	1.000	1600	11600	11600
2	1600	0.909	1454	13054	6835
3	1600	0.8264	1322	14376	5254
4	1600	0.7513	1202	15578	4467
5	1600	0.6830	1092	16670	3997
6	2000	0.6209	1242	17912	3739
7	2400	0.5645	1354	19266	3598
8	2800	0.5132	1436	20702	3527
9	3200	0.4665	1492	22194	3503
10	3600	0.4241	1526	23720	3508
11	4000	0.3854	1542	25262	-

Table 8

Machine B

Year n	Running cost, R_n (Rs.)	v^{n-1} (PWF)	$v^{n-1} R_n$	$P(n)$	$P(n) (1-v)/(1-v^n)$
1	2400	1.000	2400	7400	7400
2	2400	0.9091	2182	9582	5017
3	2400	0.8264	1983	11565	4227
4	2400	0.7513	1802	13368	3833
5	2400	0.6830	1639	15007	3598
6	2400	0.6209	1490	16497	3443
7	2800	0.5645	1581	18078	3376
8	3200	0.5132	1642	19720	3360
9	3600	0.4665	1679	21399	3378
10	4000	0.4241	1696	23095	3378
11	4400	0.3854	1696	24791	-

From the above tables 7 and 8 we find that machine A is replaced at the end of 9th year with fixed annual payment of Rs. 5503 and that the machine B is replaced at the end of 8 years and the fixed annual payment is Rs. 3360. Comparing the two figures, machine B is to be purchased.

8.3.1 Exercise

1. A person is considering purchasing a machine for his own factory. Relevant data about alternative machines are as follows.

		Machine A	Machine B	Machine C
Present investment	Rs.	10000	12000	15000
Total Annual cost	Rs.	2000	1500	1200
Life (years)		10	10	10
Salvage value	Rs.	500	1000	1200

As an adviser to the buyer, you have been asked to select the best machine, considering 12% normal rate of return. You

- (a) Single payment present worth factor (PWF) at 12 % rate for 10 years = 0.322.
 (b) Annual series present worth factor (PWFs) at 12 % rate for 10 years = 5.650.

2. Discuss the optimum replacement policy for items when maintenance cost increases with time and the money value changes with constant rate. If you wish to have a return of 0 percent per constant rate. If you wish to have a return of 10 percent per annum for investment, which of the following plan you prefer?

	Plan A	Plan B
First Cost (Rs.)	200000	250000
Scrap value for 15 year (Rs.)	150000	180000
Excess of annual revenue over annual disbursement (Rs.)	25000	30000

8.4 Items that fail completely and suddenly

There is another type of problem where we consider the items that fail completely. The item fails such that the loss is sudden and complete. Common examples are the electric bulbs, transistors and replacement of items, which follow sudden failure mechanism.

8.4.1 IR

Strategy (1)

Under this strategy equipments or facilities break down at various times. Each breakdown can be remedied as it occurs by replacement or repair of the faulty unit.

Examples: Vacuum tubes, transistors.

8.4.2 IPR

Strategy (2)

According to this strategy, before any unit fails, either each unit is replaced or preventive maintenance is performed on it as per the following rules.

- (a) Determine the optimum life I of each item. Replace all those items, which have given the optimum life though they still survive.
- (b) Replace an item if it fails before the optimum life T .
Examples: Car tyres, aircraft engines.

8.4.3 CPR (Group Replacement)

Strategy (3)

As per this strategy, an optimal group replacement period ' P ' is determined and common preventive replacement is carried out as follows.

- (a) Replacement an item if it fails before the optimum period ' P '.
- (b) Replace all the items every optimum period of ' P ' irrespective of the life of individual item.
Examples: Bulbs, Tubes, and Switches.

Among the three strategies that may be adopted, the third one namely the group replacement policy turns out to be economical if items are supplied cheap when purchased in bulk quantities. With this policy, all items are replaced at certain fixed intervals. The optimum interval can be worked out as illustrated in the example to follow.

Example The following mortality rates have been observed for a certain electric bulb.

Week	1	2	3	4	5	6	7	8
Percentage failure by end of week	5	13	25	43	68	88	96	100

There are 1000 bulbs in a factory and it costs Rs. 400 to replace and individual bulb, which has burnt out. If all bulbs were replaced simultaneously, it would cost Re. 1 per bulb. It is proposed to replace all bulbs at fixed intervals, whether or not they have burnt out, and to continue replacing burnt out bulbs as they fail. At what intervals should all the bulbs be replaced?

Solution: We make two assumptions in solving the problem.

- (1) The bulbs that fail during a week are replaced before the end of the week.
- (2) The actual probability of failures during a week for a subpopulation of the bulbs with the same age is the same as the probability of failure during the week for that sub-population.

Let P_i be the probability that a bulb newly installed fails during the i th week of its life. This can be obtained from mortality table shown below in table 9.

Table 9

End of the week	1	2	3	4	5	6	7	8
Probability of failure during the i th week	0.05	0.08	0.12	0.18	0.25	0.20	0.08	0.04

Now, we calculate the number of bulbs that fail during a particular week and require replacement.

Let n_i be the number of replacement made at the end of the i th week if all 1000 bulbs were new initially with the assumptions made above. We obtain,

$$n_0 = n_0 = 1000$$

$$n_1 = n_0 p_1 = 50$$

$$n_2 = n_0 p_2 + n_1 p_1 = 80 + 3 = 83$$

$$n_3 = n_0 p_3 + n_1 p_2 + n_2 p_1 = 120 + 4 + 4 = 128$$

$$n_4 = n_0 p_4 + n_1 p_3 + n_2 p_2 + n_3 p_1 = 180 + 6 + 7 + 6 = 199$$

$$n_5 = n_0 p_5 + n_1 p_4 + n_2 p_3 + n_3 p_2 + n_4 p_1 = 250 + 9 + 10 + 10 + 10 = 289$$

If the policy is to replace all the bulbs simultaneously every week the cost of installation of 1000 bulbs at the rate of Re. 1 per bulb is rate of Rs. 4 per bulb. Then the cost of replaced bulbs = Rs. 200. Total cost per week = Rs. 1200.

If all the bulbs were replaced at the end of two weeks, the cost of new bulbs for group replacement is Rs. 1000 and the number of bulbs to be replaced during first two weeks would be 133 and the cost for the same is $133 \times 4 =$ Rs. 532. Total cost would be Rs. 1532. This expenditure is spread over a period of two weeks. Hence the average cost per week would be Rs. 766, which is less than that if the policy is to replace the bulbs every week.

Extending the same logic, if the policy would be to replace all bulbs once in three weeks, the cost would be Rs. $1000 + 261 \times 4 =$ Rs. 2044. Hence the average cost per week would be Rs. 681. We try for the time period of four weeks and the cost would be Rs. $1000 + 1044 + 796 =$ Rs. 2840. Thus we see that the average cost per week is Rs. 710 which is more than that incurred for the policy to replace the bulbs once in three weeks. Hence the optimum period of group replacement is three weeks.

In the above analysis it was assumed to adopt the policy of group replacement and the fixed interval of replacement was three weeks. But we have to examine the policy if we replace bulbs as and when they fail (without group replacement). For this the average life of the bulb is to be calculated. Multiplying the probability can do this and the corresponding life of the bulb for all the possible cases and add them up.

Thus we have the expected life of a bulb would be $(0.05 \times 1) + (0.08 \times 2) + (0.12 \times 3) + (0.18 \times 4) + (0.25 \times 5) + (0.20 \times 6) + (0.08 \times 7) + (0.04 \times 8) = 4.62$ weeks. Hence the number of replacement of bulbs per week would be

$1000/4.62 = 216$ bulbs which would cost Rs. 864, at the rate of Rs. 4 per bulb. This is more than what we had in group replacement (cost Rs. 681). Hence we conclude that the group replacement policy is better and replace all bulbs at required interval of three weeks.

8.4.4 Exercise

- The following failure rates have been observed for certain type of light bulb.

End of week	1	2	3	4	5	6	7	8
prob. of failure to date	0.05	0.13	0.25	0.43	0.68	0.88	0.96	1.00

There are 1000 light bulbs in a factory. The cost of replacing an individual bulb is Rs. 500. If the cost of group replacement is Rs. 1.20 what is the best interval between group replacements?

- A computing machine has a large number of electronic tubes, each of which has a life normally distributed with a mean of 1200 hrs. with a standard deviation of 160 hrs. Assume the machine is in operation for two shifts ($2 \times 8 = 16$ hrs.) per day. If all the tubes were to be replaced at fixed interval, the cost is Rs. 30 for a tube. Replacement of individual tubes, which fail in service, would cost Rs. 80 for labour and parts plus the cost of computer downtime, which runs about Rs. 800 for an average tube failure. How frequently all tubes be replaced?

8.5 Staff Replacement Problem

Example A research team is planned to raise the strength of 50 chemists and then to remain at that level. The number of recruits depends on their length of service and is as follows.

Year	1	2	3	4	5	6	7	8	9	10
% left at the end of year	5	36	56	63	68	73	79	87	97	100

What is the recruitment per year to maintain the required strength? There are 8 senior posts for which the length of service is the main criterion. What is the average length of service after which a new entrant expects promotion to one of the posts?

Solution:

Table 10

At the end of year	Probability of leaving	Probability of in-service	Number of person
0	0	1.00	100
1	0.05	0.95	95
2	0.36	0.64	64
3	0.56	0.44	44
4	0.63	0.37	37
5	0.68	0.32	32
6	0.73	0.27	27
7	0.79	0.21	21
8	0.87	0.13	13
9	0.97	0.03	3
10	1.00	0.00	-
			436

From the table 10 we find probability of leaving at the end of year and also the probability of inservice at the end of year.

If we select 100 chemists every year then the total number of chemists serving in the team would have been 436. Hence, to maintain strength of 50 chemists we must recruit

$$(100/436) \times 50 = 11.4 = 12 \text{ per year (approx.)}$$

If p_i is the probability of a person to be in service at the end of i th year, then out of 12 recruited each year the total number of survivals will be $12 \times p_i$. The chemists in service at the end of year are given in the table 11.

Table 11

Year	Probability of Survival, p_i	No. of chemists at the end of year = $12 \times p_i$
0	1.00	12
1	0.95	11
2	0.64	8
3	0.44	5
4	0.32	4
5	0.32	4
6	0.27	3
7	0.21	2
8	0.13	2
9	0.03	0
10	0.00	0

If there are 8 service posts for which the length of service is the criterion, then we see from the table 11 that there are 3 persons with 6 years experience, 2 with 7 years and 2 with 8 years. The total number is 7, which is less than 8. Hence the promotion will be given at the end of 5 years.

9 Dynamic Programming

9.1 Introduction

Dynamic programming is basically a mathematical technique developed by Richard Bellman and his associates at the Rand Corporation. This technique is a powerful tool for making a sequence of interrelated decisions. There is no standard mathematical formulation of the dynamic programming problem, which is in contrast to linear programming. It is a general type of approach to problem solving and each problem has to be analyzed depending on the conditions pertaining to the problem and the particular equations used must be developed to suit the problem. In this way one should take care to formulate a dynamic programming problem, using the method of recursion.

Dynamic programming provides a solution with much less effort than exhaustive enumeration. In dynamic programming we start with a small portion of the problem and find the optimal solution for this smaller problem. We then gradually enlarge the problem finding the current optimal solution from the previous one, until we solve the original problem in its entirety. In this connection we refer to Bellman's principle of optimality, which states:

"An optimal policy has the property that, whatever the initial state and initial decision are, the remaining decisions must constitute an optimal policy with respect to the state resulting from the first decision".

Dynamic programming technique can be applied to problems of inventory control, production planning, chemical reactor design, heat exchanger designs, business situation to take an optimal decision for investments etc.

A number of illustrative examples are presented for developing dynamic programming procedure.

Example We consider the following problem called "Stage coach problem" to illustrate the concepts of dynamic programming. A salesman has to travel between points A to B indicated by the network shown in figure

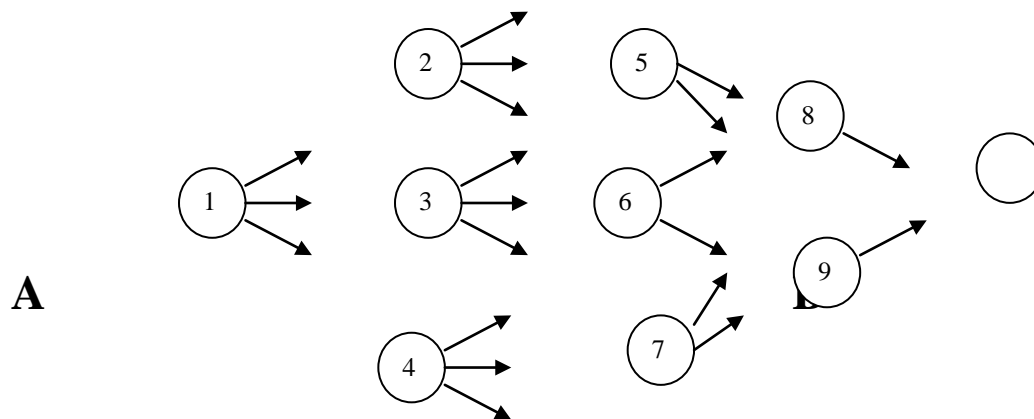

The distance to be traveled by the salesman from various states to other states, is given below.

	2	3	4	5	6	7	8	9	10
1	20	40	30						
2				70	40	60			
3				30	20	40			
4				40	10	50			
5							10	40	
6							60	30	
7							30	30	
8								30	
9								40	

Which route minimizes the total distance traveled from A to B.

Solution:

First point we note in this problem is that the decision, which is best for each successive stage, need not yield the over-all optimal decision.

If we follow the policy of minimum distance at each state, we land in a path $A \rightarrow 2 \rightarrow 6 \rightarrow 9 \rightarrow B$, with a total distance travelled as 130 km. However it should be evident that sacrificing a little on one is less distant than $A \rightarrow 2 \rightarrow 6 = (2 + 4)$.

We can solve the problem by trial and error. The number of possible routes is 18 in this example and having to calculate the total distance for all routes is a tiresome task. Instead of exhaustive enumeration of all the routes, it is better to start with a small problem and find the optimal solution for this smaller problem. Thus we extend this for the entire problem. This is what we try to do in dynamic programming.

The problem is divided into a number of stages and proceeds backwards from final destination. In this example if we were in 8 or 9 and the final destination is B we have to travel only one stage to complete the journey. This we call as one stage problem indicating that there is one more stage to go to complete the journey. If we were in 5 or 6 or 7 we have to travel 2 stages to reach the final destination. Like this we have 4 stages from A to B.

Let $x_n (n = 1, 2, 3, 4)$ be the immediate destination when there are n more stages to travel. Thus, the route selected would be $1 \rightarrow x_4 \rightarrow x_3 \rightarrow x_2 \rightarrow x_1$, where $x_1 = 10$. Let $f_n(x, x_n)$ be the total cost of the best over-all policy for the last n stages, given that the salesman is in the state s and selects x_n as the immediate destination called the state. Given s and n , let x_n^* denote the value of x_n which minimizes $f_n(s, x_n)$, and let $f_n^*(s)$ be the corresponding minimum value of $f_n(x, x_n)$. Thus, $f_n^*(s) = f_n(s, x_n^*)$. The objective is to find $f_4^*(1)$ and the corresponding policy. In dynamic programming we successively find $f_1^*(s)$, $f_2^*(s)$, $f_3^*(s)$ and $f_4^*(1)$.

The problem is divided into four stages. In one stage problem, we have one more stage to go, we can write the solution to one-stage problem as follows.

s	$f_1^*(s)$	x_1^*
8	30	10
9	40	10

When the salesman has two more stages to go, the solution requires a little analysis. When two stages are ahead to reach final destination he may occupy one of the states 5 or 6 or 7. If he is in state 5, he must go to either state 8 or 9 at a cost of 10 or 40 respectively. If he selects state 8, the minimum additional distance to travel after reaching there, is given in the above table as 30 so that the total distance for this decision would be $10 + 30 = 40$. If he selects state 9, the total distance is $40 + 40 = 80$. Comparing the two cases, it is better if he would choose 8, $x_2^* = 8$, since it gives the minimum total distance, $f_2^*(5) = 40$. In the same way for $s = 6$ and $s = 7$, we get the following results for the two stage problem shown below.

x_2	$f_2(s, x_2) = C_{s x_2} + f_1^*(x_2)$	$f_2^*(s)$	x_2^*
s	8	9	
5	$10 + 30 = 40$	$40 + 40 = 80$	40 8
6	$60 + 30 = 90$	$30 + 40 = 70$	70 9
7	$30 + 30 = 60$	$30 + 40 = 70$	60 8

The solution for the three-stage problem is obtained in a similar fashion. In the three-stage problem, we have $f_3(s, x_3) = C_{s x_3} + f_2^*(x_3)$. To illustrate, if the salesman is in state 2, and selects to go to state 5 next, the minimum total distance, $f_3(2, 5)$ would be the cost of the first stage $C_{25} = 70$ plus the minimum distance from state 5 onward $f_2^*(5) = 40$ so that $f_3^*(2, 5) = 70 + 40 = 110$, similarly $f_3^*(2, 6) = 40 + 70 = 110$ and $f_3^*(2, 7) = 60 + 60 = 120$, so that the minimum total distance from state 2 onward is $f_3^*(2) = 110$ and the immediate destination should be $x_3^* = 5$ or 6. The results are tabulated below.

x_3	$f_3(s, x_3) = C_{sx_3} + f_2^*(x_3)$			$f_3^*(s)$	x_3^*
s	5	6	7		
2	$70 + 40 = 110$	$40 + 70 = 110$	$60 + 60 = 120$	110	5 or 6
3	$30 + 40 = 70$	$20 + 70 = 90$	$40 + 60 = 120$	70	5
4	$40 + 40 = 80$	$10 + 70 = 80$	$50 + 60 = 110$	80	5 or 6

Continuing in this way, we move to the four-stage problem. The optimum distance travelled given the immediate destination, is again the sum of the distances of the first stage plus the minimum distance thereafter. The results are tabulated in table.

x_4	$f_4(s, x_4) = C_{sx_4} + f_3^*(x_4)$			$f_4^*(s)$	x_4^*
s	2	3	4		
1	$20 + 110 = 130$	$40 + 70 = 110$	$30 + 80 = 110$	110	3 or 4

We can summarize the optimal solution. From the four stage problem, we infer that the salesman should go initially to either state 3 or state 4. If he chooses $x_4^* = 3$, the three-stage problem result for $s = 3$ is $x_3^* = 5$. From this we go to the two stage problem which gives $x_2^* = 8$ for $s = 5$ and the single stage problem yields $x_1^* = 10$ for $s = 8$. Hence the optimal route is $1 \rightarrow 3 \rightarrow 5 \rightarrow 8 \rightarrow 10$. If the salesman selects $x_4^* = 4$, this leads to the other two optimal routes, $1 \rightarrow 4 \rightarrow 5 \rightarrow 8 \rightarrow 10$ and $1 \rightarrow 4 \rightarrow 6 \rightarrow 9 \rightarrow 10$. They all yield a total of $f_4^*(1) = 110$.

9.2 Features Characterizing the Dynamic Programming Problem

The physical interpretation to the abstract structure of dynamic programming problems can be provided by the example of stagecoach problem discussed in the previous section. Any problem in dynamic programming can be formulated with its basic structure similar to that of the stagecoach problem. The basic features, which characterize dynamic programming problems, are given in the following.

1. The problem can be divided up into stages, with a policy decision required at each stage.
2. Each stage has a number of states associated with it.
3. The effect of the policy decision at each stage is to change the current state into a state associated with the next stage.
4. Given the current state, an optimal policy for the remaining stage, is independent of the policy adopted in previous stages.
5. The procedure of solving the problem begins by finding the optimal policy for each state of the last stage.
6. A recursive formula can be framed to identify the optimal policy for each state with $(n - 1)$ stages remaining.
7. Using the recursive relationship the procedure is to move backward stage by stage, until it finds the optimal policy when starting at the initial stage.

Example Six units of capital is available to invest in four business ventures. The returns from each unit of investment in all the four ventures are given in the table below. Find how should the capital be allocated to business proposals in order to maximize profit.

Expected returns from Business proposals				
Unit	A	B	C	D
0	0	0	0	0
1	5	2	6	2
2	6	4	7	3
3	7	6	8	4
4	8	8	8	5
5	8	9	8	6
6	8	10	8	6

Solution:The problem has 4 stages, each business proposal representing a stage and we have six states with each stage.

One stage problem

Here we consider only one business proposal namely D (working backward) we can allot any unit of capital and the expected returns are as shown in table. For business D alone,

S	$f_1^*(s)$	x_1^*
0	0	0
1	2	1
2	3	2
3	4	3
4	5	4
5	6	5
6	6	5,6

Two-stage problem:

Here we consider two business proposals D and C. The capital is to be allocated to D and C in many possible ways. If a certain unit of capital is allotted to C (second new business) then the remaining capital only can be allocated to D and we have several combinations. The convenient way to understand about the returns is to analyse all possible combinations. Let x_1 , be the amount allotted to D and x_2 to C.

Then profit function;

$$f_2(s, x_2) = p(x_2) + f_1^*(s, x_2).$$

Capital, s,	Allotment for C	Allotment for D	Net Return from two ventures	x_2^*
$s = x_2 + x_1$	x_2	x_1	$f_2(s)$	
$s = 0$	0	0	0	
$s = 1$	0	1	$0 + 2 = 2$	
	1	0	$6 + 0 = 6^*$	1
$s = 2$	0	2	$0 + 3 = 3$	
	1	1	$6 + 2 = 8^*$	1
	2	0	$7 + 0 = 7$	
$s = 3$	0	3	$0 + 4 = 7$	
	1	2	$6 + 3 = 9^*$	1
	2	1	$7 + 2 = 9^*$	1, 2
	3	0	$8 + 0 = 8$	
$s = 4$	0	4	$0 + 5 = 5$	
	1	3	$6 + 4 = 10^*$	1
	2	2	$7 + 3 = 10^*$	1, 2
	3	1	$8 + 2 = 10^*$	1, 2, 3
	4	0	$8 + 0 = 8$	
$s = 5$	0	5	$0 + 6 = 6$	
	1	4	$6 + 5 = 11^*$	1
	2	3	$7 + 4 = 11^*$	1, 2
	3	2	$8 + 3 = 11^*$	1, 2, 3
	4	1	$8 + 2 = 10$	
	5	0	$8 + 0 = 8$	
$s = 6$	0	6	$0 + 6 = 6$	
	1	5	$6 + 6 = 12^*$	1
	2	4	$7 + 5 = 12^*$	1, 2
	3	3	$8 + 4 = 12^*$	1, 2, 3
	4	2	$8 + 3 = 11$	
	5	1	$8 + 2 = 10$	
	6	0	$8 + 0 = 8$	

Now we turn to a three-stage problem. Here we consider three business ventures. The capital can be allotted to business venture B ($= x_3$) and the remaining amount to C and D combined.

The profit function is given by

$$f_3(s, x_3) = p(x_3) + f_2^*(s-x_3)$$

Capital, s,	Allotment for B	Allotment for C and D	Net Return from three ventures	x_3^*
$s = x_3 + (s-x_3)$	(x_3)	$(s-x_3)$	$f_3(s)$	
s = 0	0	0	0	
s = 1	0	1	$0 + 6 = 6^*$	0
	1	0	$2 + 0 = 2$	
s = 2	0	2	$2 + 6 = 8^*$	0
	1	1	$4 + 0 = 4$	0, 1
s = 3	0	3	$0 + 9 = 9$	
	1	2	$2 + 8 = 10^*$	1
	2	1	$4 + 6 = 10^*$	1, 2
	3	0	$6 + 0 = 6$	
s = 4	0	4	$0 + 10 = 10$	
	1	3	$2 + 9 = 11$	
	2	2	$4 + 8 = 12^*$	2
	3	1	$6 + 6 = 12^*$	2, 3
s = 5	4	0	$8 + 0 = 8$	
	0	5	$0 + 11 = 11$	
	1	4	$2 + 10 = 12$	
	2	3	$4 + 9 = 13$	
	3	2	$6 + 8 = 14^*$	3
s = 6	4	1	$8 + 6 = 14^*$	3, 4
	5	0	$9 + 0 = 9$	
	0	6	$0 + 12 = 12$	
	1	5	$2 + 11 = 13$	
	2	4	$4 + 10 = 14^*$	
	3	3	$6 + 9 = 15$	
s = 6	4	2	$8 + 8 = 16^*$	4
	5	1	$9 + 6 = 15$	
	6	0	$10 + 0 = 10$	

Now finally, we come to the four-stage problem, in which we consider all the business proposals A, B, C and D. A certain capital is allotted to A and the remaining for B, C and D together for which the optimum result can be taken from the three-stage problem.

The profit function

$$f_4(s, x_4) = p(x_4) + f_3^*(s-x_3)$$

We analyse all possible combinations of investment with the available capital and we tabulate the net returns as shown below

Capital, s,	Allotment for A	Allotment for B,C & D	Net Return from all ventures	x_4^*
$s = x_2 + x_1$	x_4	$(s-x_4)$	$f_4(s)$	
$s = 0$	0	0	0	
$s = 1$	0	1	$0 + 6 = 6^*$	1
	1	0	$5 + 0 = 5$	
$s = 2$	0	2	$0 + 8 = 8$	
	1	1	$5 + 6 = 11^*$	0
	2	0	$6 + 0 = 6$	
$s = 3$	0	3	$0 + 10 = 10$	
	1	2	$5 + 8 = 13^*$	1
	2	1	$6 + 6 = 12$	
	3	0	$7 + 0 = 7$	
$s = 4$	0	4	$0 + 12 = 12$	
	1	3	$5 + 10 = 15^*$	1
	2	2	$6 + 8 = 14$	
	3	1	$7 + 6 = 13$	
	4	0	$8 + 0 = 8$	
$s = 5$	0	5	$0 + 14 = 14$	
	1	4	$5 + 12 = 17^*$	1
	2	3	$6 + 10 = 16$	
	3	2	$7 + 8 = 15$	
	4	1	$8 + 6 = 14$	
	5	0	$8 + 0 = 8$	
$s = 6$	0	6	$0 + 16 = 16$	
	1	5	$5 + 14 = 19^*$	1
	2	4	$6 + 12 = 18$	
	3	3	$7 + 10 = 17$	
	4	2	$8 + 8 = 16$	
	5	1	$8 + 6 = 14$	
	6	0	$8 + 0 = 8$	

Analysis of the Result

From the above table with a total capital of 6 units, we get the maximum returns as Rs. 19. This is achieved by allotting one unit to business A and the remaining 5 units to business ventures B, C and D combined. Then referring to the results of the three-stage solution we have to allot either 3 units to B or 4 units to B. Thus there are two cases to consider.

Case 1

If we allot 3 units of capital to B, then the remaining capital is only $6 - (1+3) = 2$ units, that can be allotted to business ventures C and D. Then from the results of the two-stage problem, we see the optimum allotment of one unit capital to C and the remaining one unit to D can be made. Therefore, for this case, the allotment of capital to A, B, C and D are 1, 3, 1 and 1 units respectively.

Case 2

If we allot 4 units of capital to B, then the remaining capital is only $6 - (1 + 4) = 1$ unit that can be allotted to business ventures C and D. Then from the results of the two-stage problem, we see that the optimum allotment of one unit of capital to C and nothing to D. Hence for this case, the allotments of capital to A, B, C and D are 1, 4, 1 and 0 respectively.

Both the policies yield the net return of Rs. 19.

Example A truck can carry a load of 10 tonnes of a product. There are three types of products to be transported by the truck. The weights and profits are as tabulated in the next page. With the condition that at least one of each type must be transported, determine the loading which will maximize the total profit.

Type	Profit (Rs.)	Weight (Tonnes)
A	20	1
B	50	2
C	60	2

Solution: In this problem, a decision is to be taken as to how many units of A, B and C should be transported. Thus let each stage represent transported. We divide the problem into three stages. The one stage problem is to divide the amount of product C to be transported.

One Stage Problem:

The profit per unit of C (weight = 2 tonnes) is Rs. 60. The restriction is that at least one unit of types A and B must be transported. Out of maximum 10 tonnes, (1 + 2) tonnes are allotted to A and B. Hence we can load the remaining 7 tonnes only. Let the total load be transported vary from 2 tonnes to 7 tonnes represented by s_i . Let x_i be the states representing one, two or three units ($i = 1, 2, 3$). Let f_1^* represent the optimum profit in one stage problem. The results are as in the table below.

s_i	x_i			f_1^*	x_1^*
	1	2	3		
2	1 x 60 = 60	Not feasible	Not feasible	60	1
3	1 x 60 = 60	Not feasible	Not feasible	60	1
4	1 x 60 = 60	2 x 60 = 120	Not feasible	120	2
5	1 x 60 = 60	2 x 60 = 120	Not feasible	120	2
6	1 x 60 = 60	2 x 60 = 120	3 x 60 = 180	180	3
7	1 x 60 = 60	2 x 60 = 120	3 x 60 = 180	180	3

Two Stage Problem:

Here the decision is taken as to how much of product B and C to be transported. We take the decision to allot same space to transport product B and the remaining space is available for C for which the optimum values are taken from the results of one stage problem. The optimum values are taken from the results of one stage problem. The space to be used for B and C together varies from 4 tonnes to 9 tonnes.

Let x_2 represent the amount of units if product of type B to be transported. Then the remaining ($s_2 - x_2$) tonnes of space are available for product C. The results are as shown in the table below.

s_2	x_2			f_2^*	x_2^*
	1	2	3		
2	50+60= 110	Not feasible	Not feasible	110	1
3	50+60= 110	Not feasible	Not feasible	110	1

4	50+120= 170	100+60 = 160	Not feasible	170	1
5	50+120= 170	100+60 = 160	Not feasible	170	1
6	50+180= 230	100+120 = 220	150 + 60 = 210	230	1
7	50+180= 230	100+120 = 220	150 + 60 = 210	230	1

Three Stage Problem:

Here we consider all the three types of products. Let s_3 be the space available for transporting items, x_3 be the amount of product of type A to be transported, so that $(s_3 - x_3)$ tonnes of space is available for sending products B and C together for which the optimum profit is taken from the two stage problem. The space available (s_3) varies from 5 tonnes to 10 tonnes and x_3 varies from one tonne to 6 tonnes. The results of the three stage problem are as shown in the table below.

s_3	x_3					f_3^*	x_3^*		
	1	2	3	4	5				
5	20+110=130	Not feasible	-	-	-	-	-	130	1
6	20+110=130	40+110=150	N.F	-	-	-	-	150	2
7	20+170=190	40+110=150	60+110 =170	-	-	-	-	190	1,3
8	20+170=190	40+170=210	60+110 =170	N.F	-	-	-	210	2
9	20+230=250	40+110=210	60+130 =190	80+110 =190	-	-	-	250	1
10	20+230=250	40+230=270	60+170 =230	80+170 =250	100+110=210	120+110=250	270	270	2

9.3 Exercise

1. A minimum distance pipe line is to be constructed between points A and E passing successively through one node of each B, C and D as shown in the figure on the next page. The distances from A to B and from D to E are shown in figure.

	To	1	2	3	4
From					
1	12	15	24	28	
2	15	16	17	24	
3	24	17	16	15	
4	28	21	15	12	

The distances between B and C and between C and D are given in the table. Find the solution through dynamic programming

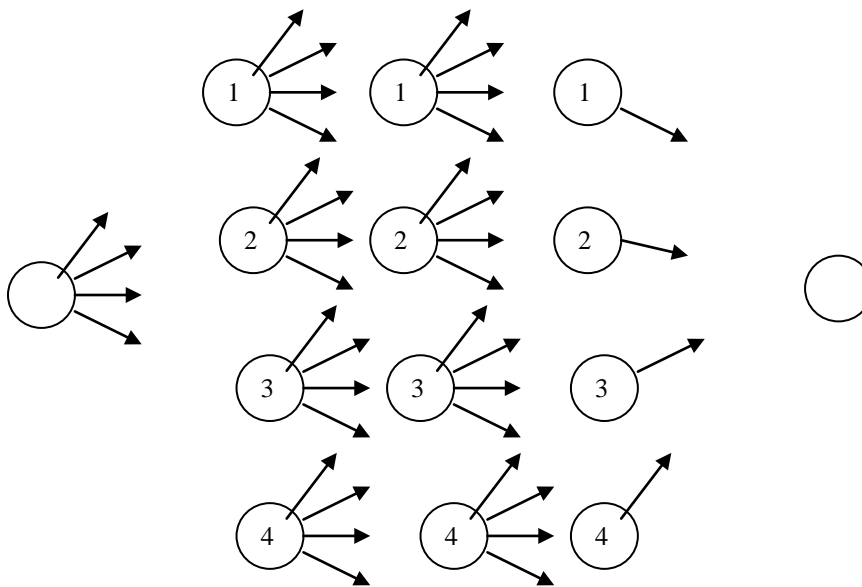

2. An investor has Rs. 50000 to invest. He has three alternatives to choose. The estimated returns for different amounts of capital invested in each alternative are tabulated. Zero allocation returns Rs. 0. What is the optimal investment policy?

Amount (Rs.)	Alternative		
	1	2	3
10000	10	20	10
20000	10	20	20
30000	30	20	20

40000	40	30	30
50000	40	30	40

10 Miscellaneous Topics in OR

10.1 Sequencing

A series, in which a few jobs or tasks are to be performed following an order, is called sequencing. In such a situation, the effectiveness measure (time, cost, distance etc.,) is a function of the order or sequence of performing a series of jobs. Problems of sequencing can be classified into two major groups.

In the first type of problem, we have n jobs to perform each of which requires processing on some or all m different machines. If we analyze the number of sequences, it runs to $(n!)^m$ possible sequences and only a few of them are technologically feasible, i.e., those which satisfy the constraints on the order in which each task has to be processed through m machines.

In the second type of problem, we have a situation with a number of machines and a series jobs to perform. Once a job is finished, we have to take a decision on the next job to be started.

Practically both types of problems seem to be intrinsically difficult and now we know solutions only for some special cases of the first type of problem. For the second type of problems, it appears that a few empirical rules have been obtained to arrive at the solution and mathematical theory has to be explored.

10.1.1 Processing n Jobs through Two Machines

The sequencing problem with n jobs through two machines can be solved easily. S.M. Johnson has developed solution procedure. The problem can be stated as follows.

1. Only two machines are involved, A and B .
2. Each job is processed in the order AB .
3. The exact or expected processing times $A_1, A_2, \dots, A_n, B_1, B_2, \dots, B_n$ are known.

A decision has to be arrived to find the minimum elapsed time from the start of the first job to the completion of the last job. It has been established that the sequence that minimizes the elapsed time are the same for both machines. The algorithm for solving the problem is as follows and due to S.M. Johnson.

1. Select the smallest processing time occurring in the list, $A_1, \dots, A_n, B_1, \dots, B_n$. If there is a tie, break the tie arbitrarily.
2. If the minimum processing time is A_i , do the i th job first. If it is B_j do the j -th job last. This decision is applicable to both machines A and B .
3. Having selected a job to be ordered, there are now $n-1$, jobs left to be ordered. Apply the steps 1 and 2 to the reduced set of processing times obtained by deleting the two machine processing times corresponding to the job that is already assigned.
4. Continue in this manner until all jobs have been ordered. The resulting ordering will minimize the elapsed time, T .

10.2 Traveling Salesman Problem

In this type of problem, we have to select a route by a salesman that will minimize the total distance traveled in visiting n cities and returning to the starting point. Another example is that if n products are to be made in some order on a continuing basis, and the set up cost for each depends on the preceding product made, we want to find cost for each depends on the preceding products that will minimize the total set up cost when the product A_i is followed by A_j . The set up costs are represented in square matrix, while the leading diagonal blank, indicating no set up cost when changing a product to itself. In traveling salesman problem, we cannot choose the element along the diagonal and this can be avoided by filling the diagonal with infinitely large elements. Another constraint we have to work with is that having started from a station A_i say, we do not want to go to the same station again until we have moved to all other stations.

10.3 Integer Programming

10.3.1 Introduction

In linear programming problem, the decision variables represent men, machines, vehicles, number of items to be produced etc. These variables make sense only if they have integer values in the final solution to the linear programming problem. This is the problem faced in real life practice. For example, if we get a solution to a problem when we decide on the number of chairs and tables produced per day in a furniture industry. As 2.53 chairs and 3.82 tables, it is meaningless because of non-integer solution. Hence a new procedure has been developed in this direction for the case of linear programming problems subjected to the additional restriction that the decision variables must have integer values.

For solving this type of integer linear programming problems, the usual technique is to apply the simplex method ignoring the integer restriction and then rounding off the non-integer values to integers in the resulting solution. There are some pitfalls in this approach. One is that it is difficult to see in which way the rounding off should be rounded off successfully, there is no guarantee that this rounded-off solution will be the optimal integer solution. In fact it may be far from optimal in terms of the value of the objective function.

This can be illustrated by the following problem.

$$\begin{array}{ll} \text{Maximize} & Z = 2x + 10y \\ \text{Subject to} & x + 10y \leq 20 \\ & x \leq 2 \end{array}$$

and x and y are non-negative integers.

Since this problem involves only two variables, a graphical solution can be easily obtained which is given below.

The graphical solution is used to find the optimal integer solution or optimal non-integer solution. The optimal non-integer solution should be $x = 2$ and $y = 9/5$ with $Z^* = 22$. If the simple procedure is adopted, then the variable with the non-integer value $y = 9/5$ is rounded off in the feasible direction to $y = 1$. Then the resulting integer solution is $x = 2$, $y = 1$ and $Z^* = 14$. But this is far from the optimal solution,

$$(x, y) = (0, 2) \text{ where } Z^* = 20$$

Therefore an efficient solution procedure for obtaining an optimal solution to integer programming problems is necessary. Some progress has been made in recent years in developing algorithms (solution procedures) for integer programming problems.

10.3.2 Methods of Integer Programming Solution

The two methods employed to solve the integer programming problems are:

- (i) Cutting Methods
- (ii) Search Methods

Cutting methods, which are developed, for integer linear problem, start with continuous optimum. Here the principle is systematically adding special constraints namely 'secondary constraints' which provide the necessary conditions for integrality.

The continuous solution space is gradually changed until its continuous optimum extreme point satisfies the integer conditions. The added secondary constraints effectively eliminate certain parts of the solution space that do

not contain feasible integer points. R.E. Gomory has developed the cutting methods. They include the "fractional algorithm" which applies to the pure integer problem and the "mixed algorithm" for mixed integer problem.

Search method is an enumeration technique in which all feasible integer points are enumerated. The most prominent search method is the "branch and bound" technique. It also starts with the continuous optimum, but systematically partitions the solution space into sub problems that eliminate parts that contain no feasible integer points. A.H. Land A.G. Doig originally developed the branch and bound algorithm. But R.J. Dakin's modification provides the computational case. The third algorithm is due to E.Balas, which is known, as 'additive algorithm', which is applied to pure zero-one problem.

10.4 Game Theory

Many conflicting situations are found in everyday life, in economic, social, political, military, battles, advertising and marketing campaign by competing business firms. In these situations two or more individuals have to take decisions that involve conflicting interests

A basic feature in many of these situations is that the final result depends primarily on the combination of strategies selected by the persons involved, called adversaries. Game theory handles such situations. Von Neumann, originally developed the Game Theory.

The following properties hold good for a competitive game.

There are finite number of competitors

Each of the competitors has a finite list of possible courses of actions known as strategy. The number of strategies need not be the same for each competitor.

A play of the game results when each of the competitors chooses a single course of action from the list of strategies available to him. The choices are assumed to be made simultaneously so that no competitor knows his opponent's choices until he is already committed to his own.

The outcome of a play depends on the strategies undertaken by the competitors. Each outcome determines the set of payments to be made to each competitor.

An objective of the game theory is to develop a rational criterion for selecting a strategy. This is done under the assumption that both players are rational and each will uncompromisingly attempt to do as well as possible, relative to his opponent. Game theory assumes that both players are actively trying to improve their own welfare in opposition to that of opponent.

There are different types of games and they may be classified indifferent ways. Some of them are,

- Two-Person Zero-sum game
- Games with mixed strategies
- Games with Dominance, and so on.

10.5 Simulation

Simulation deals with the study of (dynamic) systems over time. There are three types of simulations;

- Analogue
- Continuous
- Discrete

In analogue models, the physical (original) system is replaced by a model using analogy, which is easier for manipulation.

Continuous models represent the system undergoing smooth changes in the characteristic over a certain time period.

If the system is simulated with a model and observed it only at selected points in time, we have discrete model. These time points coincide with the occurrence of certain events, which play an important role to effect the changes in the performance of a system

Monte Carlo Simulation is the code name given by Von Neumann to the technique of solving problems too expensive for experimental solutions and too complicated for analytical treatment. If the model involves random sampling from a known probability distribution, the procedure is called Monte Carlo Simulation.

10.6 Markov Chains

A Markov process is mathematical model that describes, in probabilistic terms, the dynamic behavior of certain type of systems over time. A Markov chain is a type of Markov process.

A stochastic process is said to have the Markovian property that the conditional probability of any future event, given any past event and the present state, is independent of the past event and depends only on the present state of the process. This is called first-order Markov chain. If the outcome depends on other than the prior results it is called a higher order chain. For example a second order chain describes a process in which an outcome depends on the two previous outcomes.

10.7 Decision Analysis

In recent years, statisticians, engineers, economists and students of management have placed increasing emphasis on decision-making under conditions of uncertainty. Much of life, of course, involves making choices under uncertainty, which is, choosing from some set of alternative courses of action in situations where we are uncertain about the actual consequences that will occur for each course of action being considered.

In today's fast-moving technological world, the need for sound, rational decision making by business, industry and government is vividly apparent. Consider, for example, the area of design and development of new improved products and equipment. Typically, development from invention to commercialization is expensive and filled with uncertainty regarding both technical and commercial success. In R&D, for example, decision makers might be faced with the problem of choosing whether to pursue a parallel versus a sequential strategy (i.e. pursuing two or more designs simultaneously versus developing the most promising design, and if it fails, going to next most promising design, etc). In production, they may have to decide on a production method or process of manufacture; or choose whether to lease, subcontract, or manufacture; or select a quality-control plan. In finance, they may have to decide whether to invest in a new plant, equipment, research programs, marketing facilities, and even risky orders. In marketing, they may have to determine the pricing scheme, whether to do market research and what type and what type of it, the type of advertising campaign, and so on.

Each of these decision problems is characteristically complex and can have a significant impact on the health of a firm. It is almost impossible for any decision maker to intuitively take full account of all the factors impinging on a decision simultaneously. It thus becomes useful to find some method of separating such decision problems into parts in a way that would allow a decision maker to think through the implications of each set of factors one at a time in a rational, consistent manner. Decision analysis provides a rich set of concepts and techniques to aid the decision maker in dealing with complex decision problems under uncertainty.

Decision-making can be broadly classified into three broad categories;

- Decision making under certainty
- Decision making under risk
- Decision making under uncertainty

Most of the decisions are made on the basis of some criterion. When there is certainty or the outcome is sure, decision-making is simpler. When the outcome is not sure, then different criteria are used. They are

For decision making under risk

- Expected value criterion

- Combined expected value and variance criterion
- Known aspiration level criterion
- Most likely occurrence criterion

For decision making under uncertainty

- Laplace criterion
- Minimax (Maximin) criterion
- Savage criterion
- Hurwicz criterion

All the Operation Research Techniques discussed in this course are basically intended to help decision makers to take the most optimal decision.

**Best wishes for the decision makers.
Good luck for the students of this OR course: MTH 601!!**