

www.vaCTn.com

BIO204 Complete MERGED
PPT Slides 1 TO 91

Regards : Zarva Chaudhary

Merged File date 2021

Admin:

* Zarva Chaudhary *

Chaudhary Moazzam

* Laiba Maki *

Advances in Fermentation Technology

Lesson No.1

**Microbial
Growth
Kinetics:
Introduction**

Microbial Growth Kinetics

□ What is Microbial Growth Kinetics?

Growth → Change in state/number/size/volume or in other sense it is the ratio between birth (B) and death (D).

Microbial Growth Kinetics

□ What is Microbial Growth Kinetics?

Growth kinetics refers to the change in number or size of organisms with respect to time.

END

Lesson No.2

Microbial Growth Kinetics: Methods to Calculate/Measure Growth

Microbial Growth Kinetics

□ Methods that can be used to measure the microbial growth:

1. Turbidity of the culture
2. Total count
3. Viable count
4. Biochemical analysis
5. Graduated capillary tube
6. Dry/wet cell mass

Microbial Growth Kinetics

☐ Turbidimetric Method

- A **spectrophotometer** is used to determine **turbidity** ("cloudiness") by measuring the amount of light that passed through a suspension of cells.
- More cells → more turbidity;
- more turbidity → less light passing through the suspension
- **%T** is **percent transmission** - fewer cells present (less turbidity) will allow more light to pass through, the %T is higher when the cell number is lower.
- *Absorbance is the opposite of %T.*

$$A = -\log_{10}(T)$$

$$A = abc \quad \text{or} \quad A = \epsilon lc \quad (\text{Lambert-Beer Law})$$

Microbial Growth Kinetics

Measure of Turbidity by using Spectrophotometer

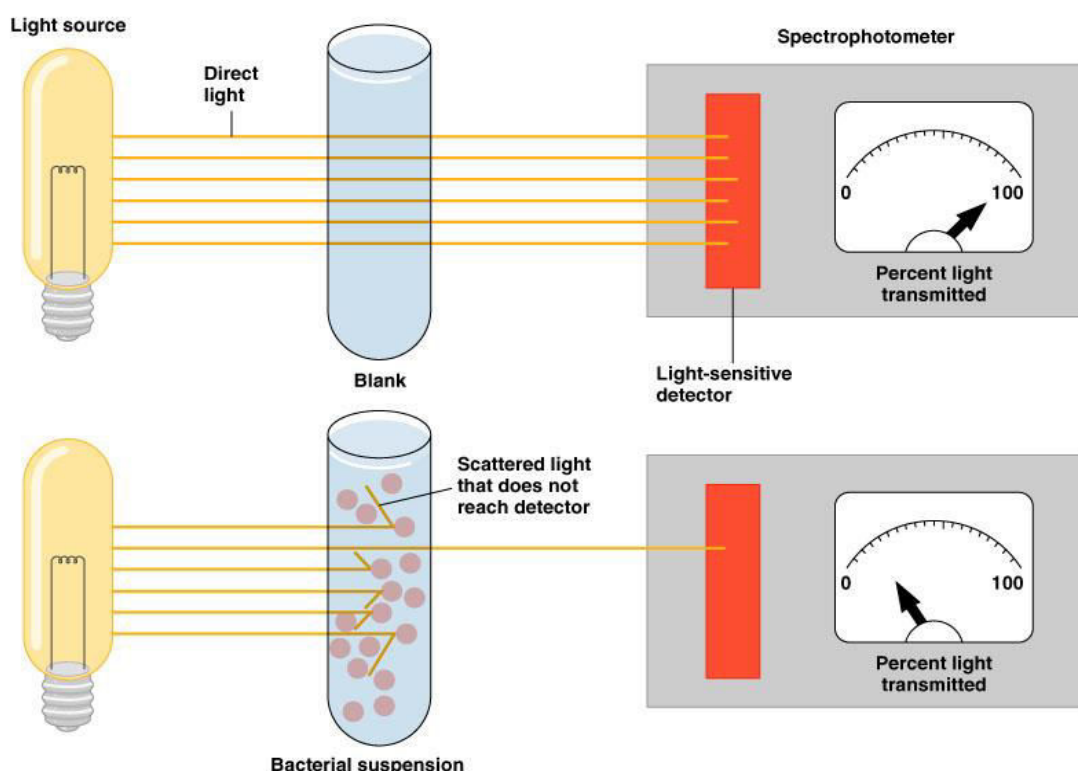

Microbial Growth Kinetics

□ Total Count

- Cell growth is also measured by counting total cell number of the microbes present in that sample. Total cells (both live and dead) of liquid sample are counted by using a **Haemocytometer/Neubauer Chamber**.
- If there is dilute culture, direct cell counting can be done. However, the cell culture of high density can be diluted. Otherwise clumps of cells would be formed which would create problem in exact counting of bacterial cells.

Microbial Growth Kinetics

Haemocytometer/Neubauer Chamber

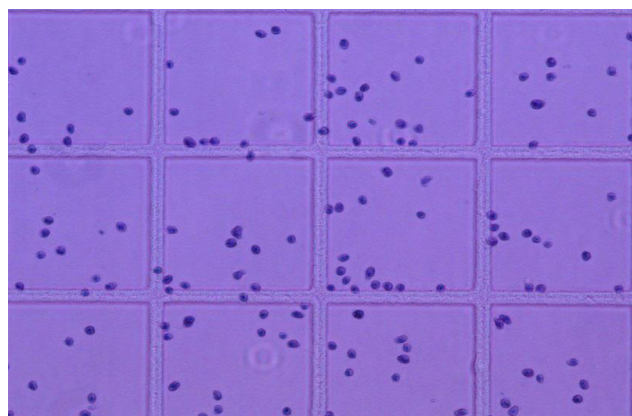
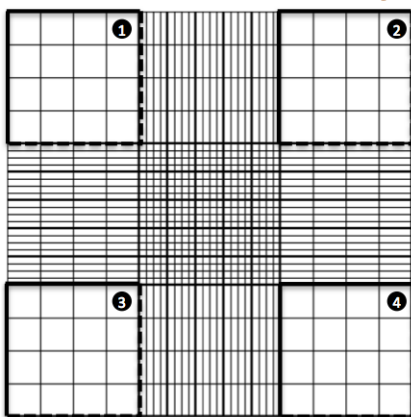

Microbial Growth Kinetics

☐ Viable Count:

A **viable cell** is defined as a cell which is **able to divide and increase cell numbers**.

Microbial Growth Kinetics

☐ Viable Count:

The normal way to perform a viable count is to determine the number of cells in the sample which is capable of forming colonies on a suitable medium.

Microbial Growth Kinetics

☐ Viable Count:

Here it is assumed that each viable cell will form one colony. Therefore, viable count is often called **plate count** or **colony count**.

Microbial Growth Kinetics

☐ Viable Count:

A **colony-forming unit (CFU)** is a unit used to estimate the number of viable bacteria or fungal cells in a sample.

Microbial Growth Kinetics

Viable Cell Counting by CFU/ml Method

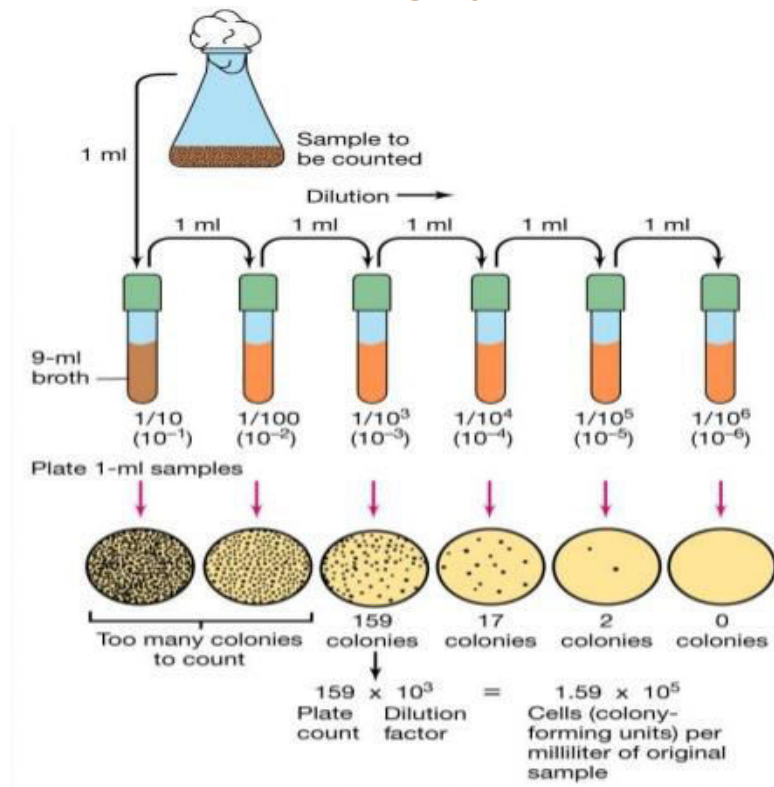

Microbial Growth Kinetics

□ Biochemical Analysis:

Direct bio-chemical measurement of some cellular component such as Nitrogen content, total protein, or total DNA content or any special compound which is not the part of media constituent.

Microbial Growth Kinetics

□ Biochemical Analysis:

Indirect **measurement of chemical activity** such as rate of O₂ consumption or production CO₂ production or vice versa, in short: rate of respiration.

END

Advances in Fermentation Technology

Lesson No.3

Microbial Growth Kinetics: Batch Culture-1

Microbial Growth Kinetics

□ Batch Culture:

In batch processing, a batch of culture medium in a fermenter is inoculated with a microorganism (the 'starter culture').

Microbial Growth Kinetics

□ Batch Culture:

Fermentation proceeds for a certain duration (the 'fermentation time' or '**batch time**'), and the **product is harvested at the end.**

Microbial Growth Kinetics

□ Batch Culture:

- It is a closed system which contains an **initial limited amount of nutrient**.
- We put all the things at one time here and '**s**' (concentration of substrate) **will remain same**.
- Minor change in volume.

Microbial Growth Kinetics

Microbial Growth Curve in Closed System

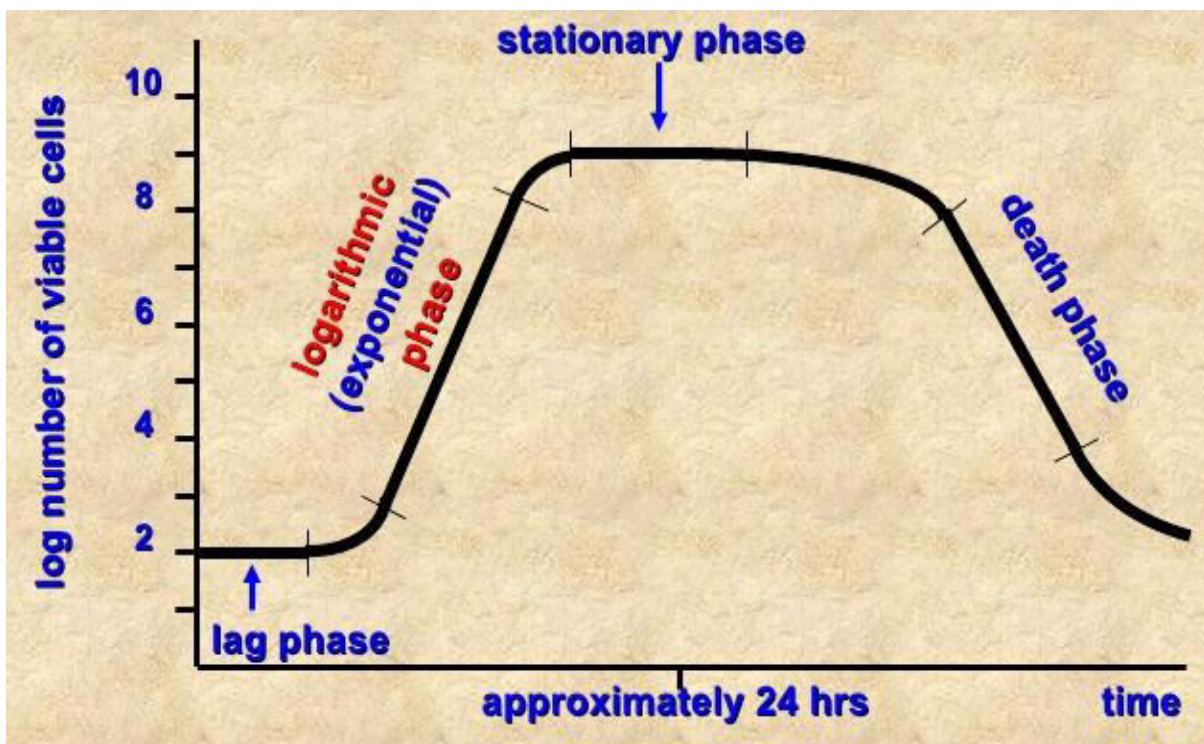

Microbial Growth Kinetics

□ Growth Kinetics in Batch Culture:

Biomass/Mass Culture → 'x'

- Substrate → 's'
- Product → 'p' (concentration of product)
- x, s, p changes with respect to time 't'.

Microbial Growth Kinetics

□ Growth Kinetics in Batch Culture:

In case of Product: Sometimes 'x' is itself product (e.g. Baker's Yeast) and sometimes product is directly linked/associated with biomass (e.g. DNA \propto Biomass, Primary metabolites).

END

Lesson No.4

Microbial Growth Kinetics: Batch Culture-2

Microbial Growth Kinetics

□ Relationship between 'x' & 't':

Following a period during which the growth rate of the cells gradually increases, the cells grow at a constant, maximum, rate and this period is known as **log** or **exponential, phase**.

Microbial Growth Kinetics

The exponential phase may be described as:

Microbial growth follows the pattern;

$$\begin{aligned} &2^0X_0 \rightarrow 2^1X_0 \rightarrow 2^2X_0 \\ &\rightarrow 2^3X_0 \rightarrow 2^4X_0 \dots \\ &\dots 2^tX_0 \end{aligned}$$

Microbial Growth Kinetics

Doubling time (t_d) is defined as the time required for cell mass to double. Hence number of generation 'n' after time t are given by:

$$N = t/t_d$$

END

Lesson No.5

Microbial Growth Kinetics: Batch Culture-3

Microbial Growth Kinetics

Cell density (X_t)
after time 't' will
be:

$$X_t = X_o 2^n = X_o 2^{t/d}$$

$$x \propto t$$

$$dX \propto dt$$

change in biomass
 \propto change in time

Microbial Growth Kinetics

$$dX = \mu \cdot X \cdot dt$$

$$dX/dt = \mu \cdot X$$

Where,

X = concentration of microbial biomass

t = time, (mostly in hrs)

μ = is the Specific Growth Rate per unit cell mass

Microbial Growth Kinetics

On applying integration equation this equation ($dX/dt = \mu \cdot X$) becomes:

$$X_t = x_o e^{\mu t}$$

X_o = original biomass concentration

X_t = biomass concentration after the time interval *t* hours

e = base of the natural logarithm

Microbial Growth Kinetics

To convert equation $x_t = x_o e^{\mu t}$ into linear equation, take natural logarithm by which this equation becomes:

$$\ln X_t = \ln X_o + \mu t \quad (\ln e)$$
$$\ln X_t = \ln X_o + \mu t, \text{ because } \ln e = 1$$

This equation fit to linear regression equation:

$$Y = a + bX$$

Where:

Y= Vertical axis (dependent variable)

X=Horizontal axis (independent variable)

a= intersect point on plot

b= slope of line (specific growth rate)

Microbial Growth Kinetics

If, $\ln X$ is taken along Y-axis & **T** is taken on X-axis, a plot of the natural logarithm of biomass concentration against time should yield a straight line, the slope of which would equal μ .

Microbial Growth Kinetics

By using this relationship:

$\ln X_t = \ln X_o + \mu t$, we can calculate **doubling time** by putting $X_t = 2X_o$

$$\ln 2X_o = \ln X_o + \mu t_d$$

$$\ln 2X_o - \ln X_o = \mu t_d$$

$$\ln (2X_o/X_o) = \mu t_d$$

$$\ln (2) = \mu t_d$$

$$\ln 2/\mu = t_d$$

END

Advances in Fermentation Technology

Lesson No.6

Microbial Growth Kinetics: Batch Culture-4

Microbial Growth Kinetics

There are two types of organisms:

- i. Unicellular
- ii. Multicellular

μ (specific growth) is applied only when cell is unicellular, (bacteria & yeast) e.g. independent of other cells.

Microbial Growth Kinetics

In case of multicellular organisms, some cells are growing at one time while other are rest at the same time. So, at one time different cells are at different phases of their growth e.g. some are at log phase while others are at stationary phase etc.). That's why we cannot calculate μ properly in this case.

$$Dx/dt = \mu x$$

$$dH/dt = \mu H$$

$$dA/dt = \mu A$$

Where,

H=total length, and A=number of growing tips or change in area of the colony

Microbial Growth Kinetics

In Submerged fermentation/culture a mycelial organism may grow as dispersed hyphal fragments or as pellets. The growth of pellets will be exponential until the density of the results in diffusion limitation. Under such limitation the central biomass of the pellet will not receive a supply of nutrients, nor will potentially toxic secretions/products diffuse out. Thus effect the growth of the pellet, only growth proceed from the outer shell of biomass which is the actively growing zone and was described by Pirt as:

$$M^{1/3} = kt + M_0^{1/3}$$

where M_0 and M are the mycelial mass at time 0 and t , respectively

Microbial Growth Kinetics

Effect of Substrate Concentration 'S':

The **Growth Yield** (Y) is the increase in cell mass (dX) which results due to consumption of a small amount of substrate (dS)

END

$$Y = dX/dS$$

Lesson No.7

Microbial Growth Kinetics: Batch Culture-5 (Effect of Substrate Concentration)

Microbial Growth Kinetics

Monod proposed growth yield to constant reproducible quantity under identical conditions

$$X_t - X_o = Y(S_o - S_t)$$

Where, X and S are cell mass and substrate concentration respectively, at time t and X_o and S_o are initial cell mass and substrate concentration respectively. If the substrate in equation is growth limiting substrate and the X_{max} is the maximum cell mass level reached after total consumption of substrate, when there is zero residual substrate (s) then

$$X_{max} - X_o = YS_o$$

Microbial Growth Kinetics

Above than some extent if concentration of 's' is increased its become toxic.

$$X = Y (S_0 - s)$$

Where,

Y= Yield (concentration of biomass produced in fermentation)

S₀ = Initial substrate concentration

s= Residual substrate (which remains at end)

As, s=0 (residual substrate 's' remained at end is usually zero)

$$X = Y S_0$$

Microbial Growth Kinetics

The specific growth rate is generally found to be function of three parameters:

1. The concentration of growth limiting substrate, S
2. The maximum specific growth rate, μ_{\max}
3. A substrate-specific constant, K_s

$$\mu = \mu_{\max} / K_s + S \quad (\text{MONOD EQUATION})$$

Specific growth rate is independent of substrate concentration as long as excess substrate is present.

Microbial Growth Kinetics

$$\mu = \mu_{\max} / K_s + S$$

Taking the reciprocal values in the Monod equation and rearranging it:

$$1/\mu = K_s + S/\mu_{\max} S$$

or

$$1/\mu = K_s/\mu_{\max} S + S/\mu_{\max} S$$

$$1/\mu = K_s/\mu_{\max} S + 1/\mu_{\max}$$

Microbial Growth Kinetics

To convert Monod equation into Linear equation we can write it as:

$$1/\mu = 1/\mu_{\max} + K_s/\mu_{\max} S$$

$$Y = a + bx$$

The plot of $1/\mu$ against $1/S$ produces a straight line with intercept on the y axis $1/\mu_{\max}$ and slope equals to:

$$K_s/\mu_{\max}$$

END

Lesson No.8

Microbial Growth Kinetics: Batch Culture-6 Process Kinetics

Microbial Growth Kinetics

□ Process Kinetics:

Material balance for a process can be written as:

$$\text{Accumulation} = \text{Growth} - \text{Death}$$

Substrate accumulation = substrate feed – substrate used for growth – substrate used for product formation – substrate used for maintenance energy

$$-dS/dt = \mu \cdot X/Y_{x/s} - q_p \cdot X/Y_{p/s} - m \cdot X$$

Similarly product formation: **Product \propto Time**

$$p \propto t$$

$$dp \propto dt$$

$$dp/dt = q_p$$

$$dp/dt = q_p X$$

$$dp/dt = q_p X - kP$$

(kP = kinetic parameters)

Microbial Growth Kinetics

In fermentation some products are directly proportional to biomass concentration, while some are partially proportional with biomass. **When product is partially proportional with biomass:**

$$dp/dt = q_p \cdot X$$

When product is directly proportional with biomass:

$$dp/dx = Y_{P/X}$$

Yield effected with substrate

$$dp/ds = Y_{P/S}$$

Microbial Growth Kinetics

As we have:

$$dp/dx = Y_{P/X}$$

$$dx/dt \cdot dp/dx = Y_{P/X} \cdot dx/dt$$

$$(As: dx/dt = \mu x)$$

$$dp/dt = Y_{P/X} \cdot \mu x$$

$$q_p x = Y_{P/X} \cdot \mu x$$

$$q_p = Y_{P/X} \cdot \mu$$

For Substrate:

$$q_s = Y_{P/S} \cdot \mu$$

END

Lesson No.9

Microbial Growth Kinetics: Batch Culture-7

Microbial Growth Kinetics

Borrow *et al.*, (1961)

divided the growth of organism into several phases:

- **The balanced phase:** equivalent to the early to middle exponential phase.
- **The storage phase:** equivalent to the late exponential phase where the increase in mass is due to the accumulation of lipid and carbohydrate.
- **The maintenance phase:** equivalent to the stationary phase.

Microbial Growth Kinetics

□ Growth Phases with respect to metabolites:

Following terms were coined by Bu'Lock *et al.*, (1965):

- i. Trophase
(Refers to exponential phase- stage where primary metabolites are produced).

Microbial Growth Kinetics

□ Growth Phases with respect to metabolites:

- ii. Idiophase
(Usually refers to stationary or death phase- where secondary, tertiary or other metabolites are produced).

END

Lesson No.10

Microbial Growth Kinetics: Fed- Batch Culture-1

Microbial Growth Kinetics

□ Fed-Batch Culture:

Yoshida *et al.*, (1973) introduced the term fed-batch culture to describe batch cultures which are fed continuously, or sequentially, **with medium, without the removal of culture fluid.**

Microbial Growth Kinetics

A fed-batch culture is established initially in batch mode and is then fed according to one of the following feed strategies:

- i. The same medium used to establish the batch culture is added, resulting in an increase in volume.
- ii. A solution of the limiting substrate at the same concentration as that in the initial medium is added, resulting in an increase in volume.
- iii. A concentrated solution of the limiting substrate is added at a rate less than in (i) and (ii), resulting in an increase in volume.
- iv. A very concentrated solution of the limiting substrate is added at a rate less than in (i), (ii) and (iii), resulting in an insignificant increase in volume.

Microbial Growth Kinetics

Fed-batch systems employing strategies

(i) and (ii) are described as variable volume, whereas a system employing strategy (iv) is described as fixed volume.

Microbial Growth Kinetics

The use of strategy (iii) gives a culture intermediate between the two extremes of variable and fixed volume.

END

Advances in Fermentation Technology

Lesson No.11

**Microbial
Growth
Kinetics:
Fed- Batch
Culture-2**

Microbial Growth Kinetics

Variable volume:

(The kinetics of variable volume in fed-batch culture have been developed by **Dunn and Mor** (1975) and **Pirt** (1974, 1975, 1979).

Microbial Growth Kinetics

Consider a batch culture in which growth is limited by the concentration of one substrate; the biomass at any point in time will be described by the equation:

$$x_t = x_o + Y (S_R - s)$$

where x_t is the biomass concentration after time, t hours,

and x_o is the inoculum concentration.

The final biomass concentration produced when $s = 0$ may be described as x_{max} and, provided that x_o is small compared with x_{max} :

$$x_{max} \approx Y \cdot S_R$$

Microbial Growth Kinetics

If, at the time when $x = x_{max}$ a medium feed is started such that the dilution rate is less than μ_{max} , virtually all the substrate will be consumed as fast as it enters the culture, thus:

$$FS_R \approx \mu (X/Y)$$

where F is the flow rate of the medium feed, and X is the total biomass in the culture, described by $X = xV$, where V is the volume of the culture medium in the vessel at time t .

From this equation it may be concluded that input of substrate is equaled by consumption of substrate by the cells.

Microbial Growth Kinetics

Thus, $(ds/dt) \approx 0$. Although the total biomass in the culture (X) increases with time, cell concentration (x) remains virtually constant, that is $(dx/dt) \approx 0$ and therefore $\mu \approx D$. This situation is termed a **quasi-steady state**.

END

Lesson No.12

Microbial Growth Kinetics: Fed- Batch Culture-3

Microbial Growth Kinetics

As time progresses the dilution rate will decrease as the volume increases and D will be given the expression:

$$D = F / (V_o + F_t)$$

where V_o is the original volume.

Microbial Growth Kinetics

Thus, according to Monod kinetics, residual substrate should decrease as D decreases resulting in an increase in the cell concentration.

However, over most of the range of μ which will operate in fed-batch culture, S_R will be much larger than K_S so that, for all practical purposes, the change in residual substrate concentration would be extremely small and may be considered as zero. Thus, provided that D is less than μ_{\max} and K_S is much smaller than S_R , a quasi-steady state may be achieved..

Microbial Growth Kinetics

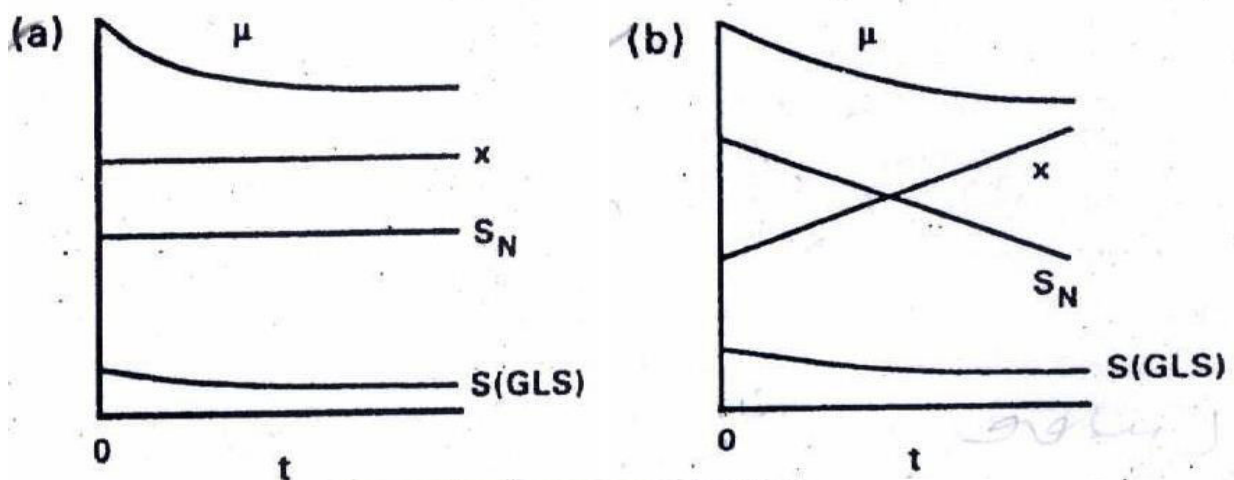

μ = specific growth rate
 x = biomass concentration
 $S(\text{GLS})$ = growth limiting substrate
 S_N = any other substrate than $S(\text{GLS})$
(a) Variable volume fed-batch culture.
(b) Fixed volume fed-batch culture.
(Pirt, 1979).

Microbial Growth Kinetics

The major difference between the **steady state of a chemostat** and the **quasi steady state** of a fed-batch culture is that μ is constant in the chemostat but decreases in the fed-batch

END

Advances in Fermentation Technology

Lesson No.13

**Microbial
Growth
Kinetics:
Fed- Batch
Culture-4**

Microbial Growth Kinetics

Pirt (1979) has expressed the change in product concentration in variable volume fed-batch culture

$$dp/dt = q_p x - Dp$$

Microbial Growth Kinetics

Thus, product concentration changes according to the balance between production rate and dilution by the feed.

Fed-batch quasi steady state change over the time of the fermentation.

Product concentration in a fed-batch system over the time of the fermentation will be dependent on the relationship between q_p and μ (hence D).

If q_p is strictly growth related then it will change as μ with D and, thus, the product concentration remain constant.

However, if q_p is constant and independent of μ , then product concentration will the start of the cycle when Dp is greater than $q_p x$, but will rise with time as D decreases and $q_p x$ become greater than Dp .

Microbial Growth Kinetics

If q_p is related to μ in a complex manner then product concentration will vary according relationship. Thus, the feed strategy of a system would be optimized according to the ship between q_p and μ .

END

Advances in Fermentation Technology

Lesson No.14

**Microbial
Growth
Kinetics:
Fed- Batch
Culture-5**

Microbial Growth Kinetics

Fixed volume fed-batch Culture:

Pirt (1979) described the kinetics of fixed volume fed-batch culture as follows. Consider a batch culture in which the growth of the process organism depleted the limiting substrate to a limiting level.

Microbial Growth Kinetics

If the limiting substrate is then added in a concentrated feed such that the broth volume remains almost constant then:

$$dx/dt = GY$$

where G is the substrate feed rate ($\text{g dm}^{-3} \text{h}^{-1}$)
and Y is the yield factor.

But $dx/dt = \mu x$, thus substituting for dx/dt in equation (2.34) gives:

$$\mu x = GY, \text{ and thus:}$$
$$\mu = GY/x$$

Microbial Growth Kinetics

Provided that GY/x does not exceed μ_{max} then the limiting substrate will be consumed as soon as it enters the fermenter and $ds/dt \simeq 0$. However, dx/dt may not be equated to zero, as in the case of variable volume fed- batch, because the biomass concentration, as well as the total amount of biomass in the fermenter, will increase with time. Biomass concentration is given by the equation:

$$x_t = x_a + GY_t$$

where x_t is the biomass after operating in fed- batch for t hours

and x_a is the biomass concentration at the onset of fed-batch culture

Microbial Growth Kinetics

As biomass increases then the specific growth rate will decline according to the equation.

END

Lesson No.15

Microbial Growth Kinetics: Fed- Batch Culture-6

Microbial Growth Kinetics

Pirt (1979) described the product balance in a fixed volume fed-batch system as:

$$dp / dt = q_p x$$

but substituting for x from equation gives:

$$dp/dt = q_p(x_a + GYt)$$

Microbial Growth Kinetics

If q_p is strictly growth-rate related then product concentration will rise linearly as for biomass.

However, if q_p is constant then the rate of increase in product concentration will rise as growth rate declines, i.e. as time progresses and x increases.

If q_p is related to μ in a complex manner then the product concentration will vary according to that relationship.

Microbial Growth Kinetics

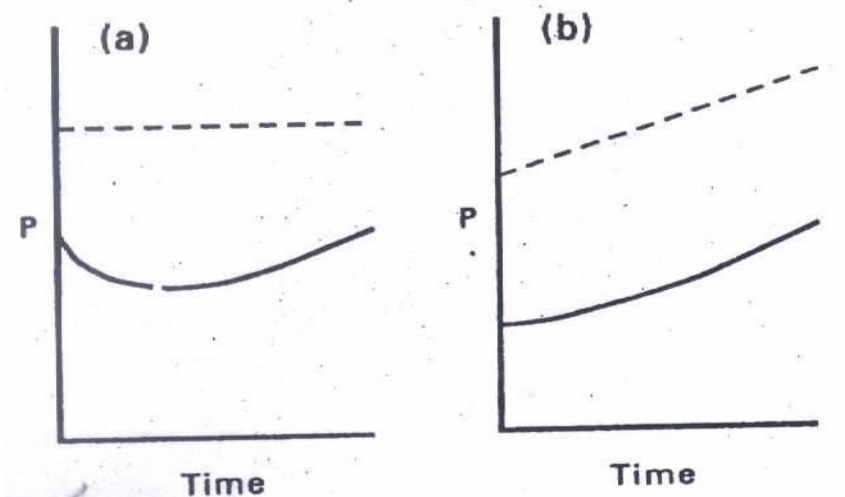

Product concentration (p) in fed-batch culture when q_p is growth related (-----) or non-growth related, i.e. q_p constant (———)

(a) Variable volume fed-batch culture.

(b) Fixed volume fed-batch culture.

(Modified from Pirt, 1979.)

Microbial Growth Kinetics

As in the case of variable volume fed-batch the feed profile would be optimized according to the relationship between q_p and μ .

END

Advances in Fermentation Technology

Lesson No.16

**Microbial
Growth
Kinetics:
Continuous
Culture-1**

Microbial Growth Kinetics

- Exponential growth in batch culture may be prolonged by the addition of fresh medium to the vessel. Provided that the medium has been designed such that growth is substrate limited (i.e. by some component of the medium), and not toxin limited, exponential growth will proceed until the additional substrate is exhausted. This exercise may be repeated until the vessel is full.
- However, if an overflow device were fitted to the fermenter such that the added medium displaced an equal volume of culture from the vessel then continuous production of cells could be achieved.

Microbial Growth Kinetics

If medium is fed continuously to such a culture at a suitable rate, steady state is achieved eventually, that is, formation new biomass by the culture is balanced by the loss cells from the vessel.

Microbial Growth Kinetics

The flow of medium into the vessel is related to the volume of the vessel by the term dilution rate, D , defined as:

$$D = F/V$$

Where, F is the flow rate ($\text{dm}^3 \text{h}^{-1}$)
and V is the volume (dm^3)

Thus, D is expressed in the units h^{-1} . The net change in cell concentration over a time period may be expressed as:

$$dx/dt = \text{growth} - \text{output}$$

$$dx/dt = \mu x - Dx$$

Microbial Growth Kinetics

OR

Under steady state conditions the cell concentration remains constant, thus $dx/dt = 0$ and:

$$\mu x = Dx$$

$$\mu = D$$

Microbial Growth Kinetics

Thus, under steady-state conditions the specific growth rate is controlled by the dilution rate, which is an experimental variable. It will be recalled that under batch culture conditions an organism will grow at its maximum specific growth rate and, therefore, it is obvious that a continuous culture may be operated only at dilution rates below the maximum specific growth rate. Thus, within certain limits, the dilution rate may be used to control the growth rate of the culture.

Microbial Growth Kinetics

The growth of the cells in a continuous culture of this type is controlled by the availability of the growth limiting chemical component of the medium and, thus, the system is described as a chemostat.

END

Lesson No.17

Microbial Growth Kinetics: Continuous Culture-2

Microbial Growth Kinetics

The mechanism underlying the controlling effect of the dilution rate is essentially the relationship expressed in following equation as demonstrated by Monod in 1942:

$$\mu = \mu_{max} s / (K_s + s)$$

At steady state, $\mu = D$, and, therefore,

$$D = \mu_{max} \bar{s} / (K_s + \bar{s})$$

Where \bar{s} is the steady state concentration of substrate in the chemostat, and

$$\bar{s} = K_s D / (\mu_{max} - D) \dots\dots\dots (\text{Eq. 1})$$

Microbial Growth Kinetics

Equation: $\bar{s} = K_s D / (\mu_{max} - D)$ predicts that the substrate concentration is determined by the dilution rate.

In effect, this occurs by growth of the cells depleting the substrate to a concentration that supports the growth rate equal to the dilution rate. If substrate is depleted below the level that supports the growth rate dictated by the dilution rate, the following sequence of events takes place:

(mentioned in next slide)

Microbial Growth Kinetics

- i. The growth rate of the cells will be less than the dilution rate and they will be washed out of the vessel at a rate greater than they are being produced, resulting in a decrease in biomass concentration.
- ii. The substrate concentration in the vessel will rise because fewer cells are left in the vessel to consume it.
- iii. The increased substrate concentration in the vessel will result in the cells growing at a rate greater than the dilution rate and biomass concentration will increase.
- iv. The steady state will be re-established.

Microbial Growth Kinetics

Thus, a chemostat is a nutrient-limited self-balancing culture system which may be maintained in a steady state over a wide range of sub-maximum specific growth rates. The concentration of cells in the chemostat at steady state is described by the equation:

$$\bar{x} = Y (S_R - \bar{s}) \dots \dots \text{Eq. 2}$$

Microbial Growth Kinetics

Where, \bar{x} in **Eq. 2** is the steady-state cell concentration in the chemostat. By combining equations (1) and (2), then:

$$\bar{x} = Y [S_R - \{K_s D / (\mu_{max} - D)\}]$$

Thus, the biomass concentration at steady state is determined by the operational variables, S_R and D . If S_R is increased, \bar{x} will increase but \bar{s} , the residual substrate concentration in the chemostat, will remain the same.

Microbial Growth Kinetics

If D is increased, μ will increase ($\mu = D$) and the residual substrate at the new steady state would have increased to support the elevated growth rate; thus, less substrate will be available to be converted into biomass, resulting in a lower steady state value.

END

Advances in Fermentation Technology

Lesson No.18

**Microbial
Growth
Kinetics:
Continuous
Culture-3**

Microbial Growth Kinetics

An alternative type of continuous culture to the **chemostat** is the **turbidostat**, where the concentration of cells in the culture is kept constant by controlling the flow of medium such that the turbidity of the culture is kept within certain, narrow limits. This may be achieved by monitoring the biomass with a photoelectric cell and feeding the signal to a pump supplying medium to the culture such that the pump is switched on if the biomass exceeds the set point and is switched off if the biomass falls below the set point. **Systems other than turbidity may be used to monitor the biomass concentration, such as CO₂ concentration or pH in which case it would be more correct to term the culture a biostat.**

Microbial Growth Kinetics

The chemostat is the more commonly used system because it has the advantage over the biostat of not requiring complex control systems to maintain a steady state. However, the biostat may be advantageous in continuous enrichment culture in avoiding the total washout of the culture in its early stages.

Microbial Growth Kinetics

The effect of dilution rate on the steady-state biomass and residual substrate concentrations in a chemostat of a microorganism with a low K_s value for the limiting substrate, compared with the initial substrate concentration

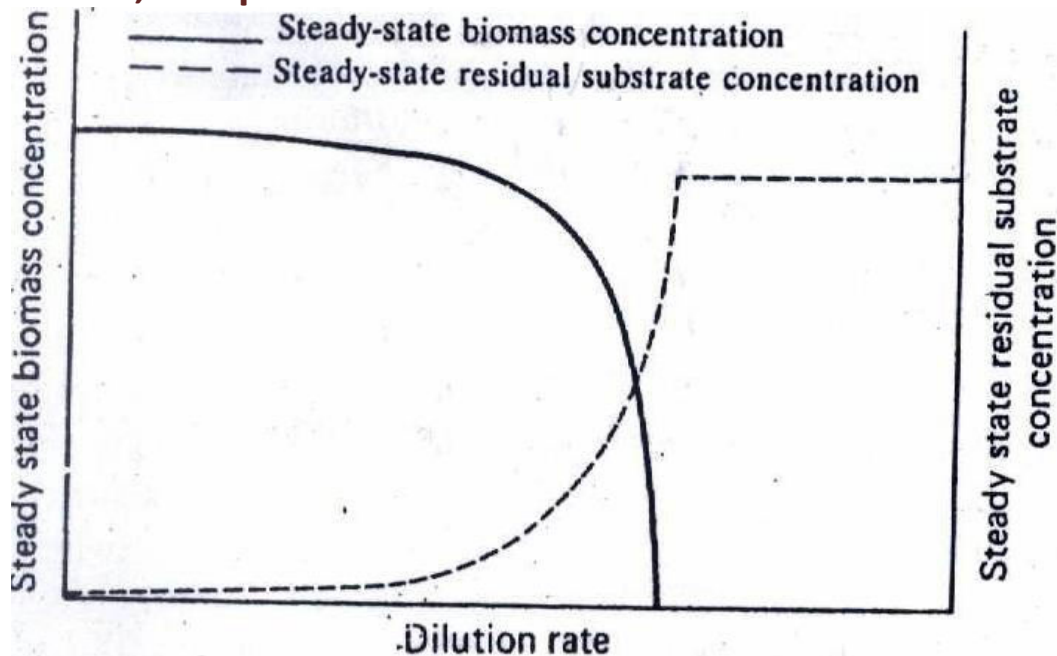

Microbial Growth Kinetics

Figure in previous slide illustrates the continuous culture behavior of a hypothetical bacterium with a low K_s value for the limiting substrate, compared with the initial limiting substrate concentration. With increasing dilution rate, the residual substrate concentration increases only slightly until D approaches μ_{max} when s increases significantly. The dilution rate at which x equals zero (that is, the cells have been washed out of the system) is termed the critical dilution rate (D_{crit}) and is given by the equation:

$$D_{crit} = \mu_{max} S_R / (K_s + S_R)$$

Microbial Growth Kinetics

The kinetic characteristics of an organism (and, therefore, its behavior in a chemostat) are described by the numerical values of the constants Y , μ_{max} and K_s . The value of Y affects the steady-state biomass concentration; the value of μ_{max} affects the maximum dilution rate that may be employed and the value of K_s affects the residual substrate concentration (and, hence, the biomass concentration) and also the maximum dilution rate that may be used.

Microbial Growth Kinetics

The effect of dilution rate on the steady-state biomass and residual substrate concentrations in a chemostat of a microorganism with a high K_s value for the limiting substrate, compared with the initial substrate concentration

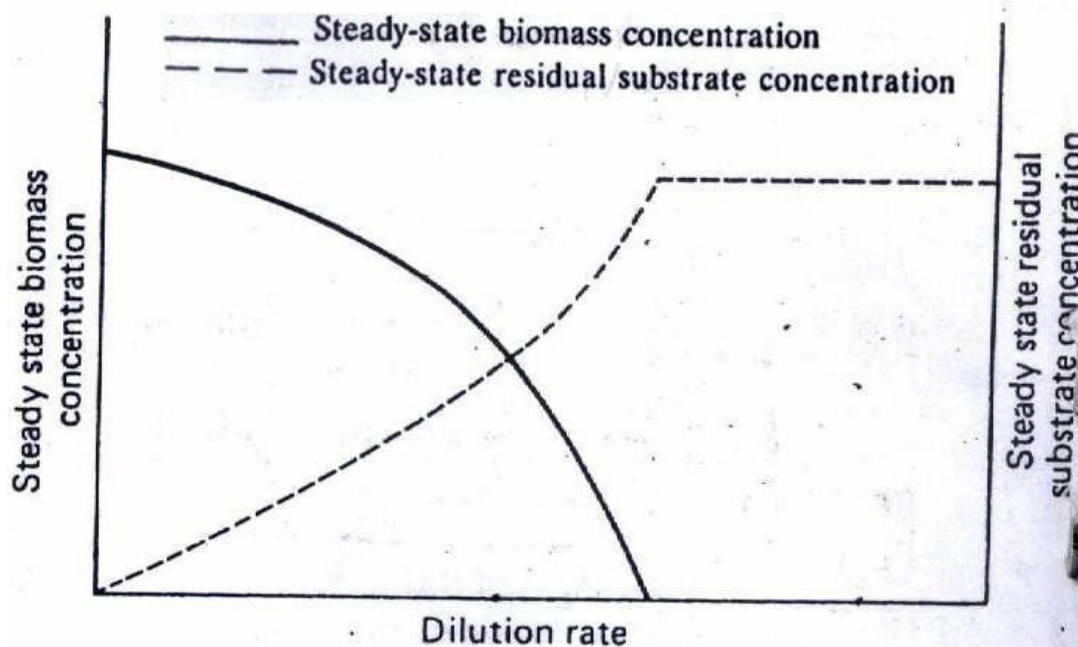

Microbial Growth Kinetics

Figure in previous slide illustrates the continuous culture behavior of a hypothetical bacterium with high K_s for the limiting substrate compared with the initial limiting substrate concentration. With increasing dilution rate, the residual substrate concentration increases significantly to support the increased growth rate. Thus, there is a gradual increase in s and a decrease in x as D approaches D_{crit} .

Microbial Growth Kinetics

Thus, D_{crit} is affected by the constants, μ_{max} and K_s , and the variable, S_R ; the larger S_R the closer is D_{crit} to μ_{max} . However, μ_{max} cannot be achieved in a simple steady state chemostat because substrate limited conditions must always prevail.

END

Lesson No.19

Microbial Growth Kinetics: Continuous Culture-4

Microbial Growth Kinetics

The effect of increased initial substrate concentration on the steady-state biomass and residual substrate concentrations in a chemostat

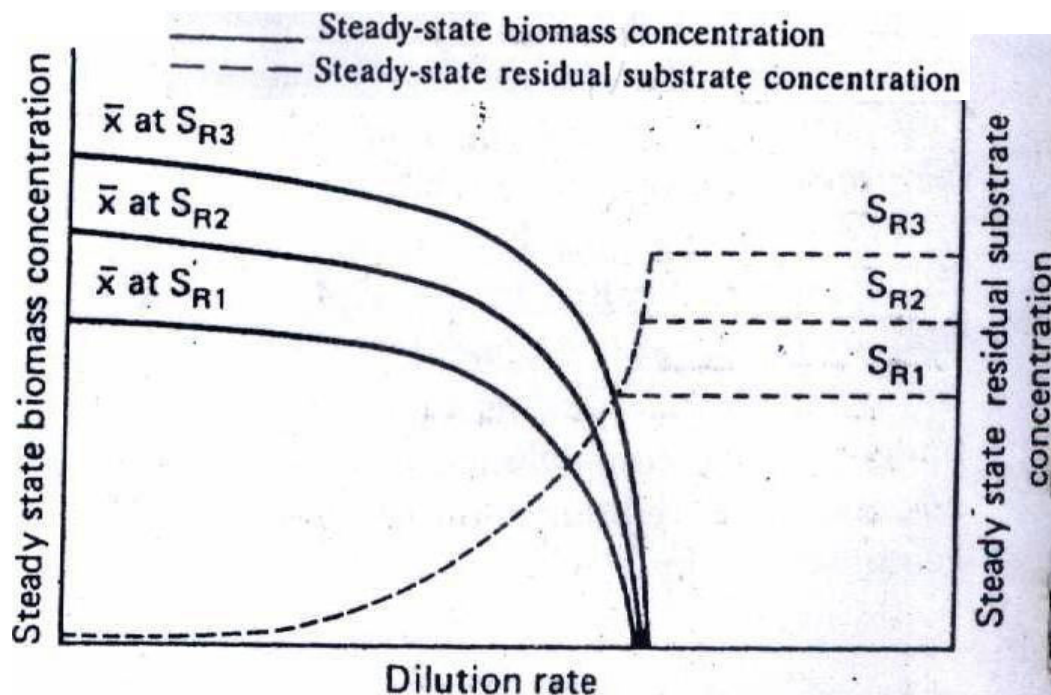

Microbial Growth Kinetics

Figure in previous slide illustrates the effect of increasing the initial limiting substrate concentration on \bar{x} and \bar{s} . As S_R is increased, \bar{x} so increases, but the residual substrate concentration is unaffected. Also D_{crit} increases slightly with an increase in S_R .

Whereas, S_{R1} , S_{R2} and S_{R3} in the figure represent increasing concentrations of the limiting substrate in the feed medium.

Microbial Growth Kinetics

The results of chemostat experiments may differ from those predicted by the foregoing theory. The reasons for these deviations may be anomalies associated with the equipment or the theory not predicting the behavior of the organism under certain circumstances. Practical anomalies include imperfect mixing and wall growth. Imperfect mixing would cause an increase in the degree of heterogeneity in the fermenter when some organisms being subject to nutrient excess whilst others are under severe limitation. This phenomenon is particularly relevant to very low dilution rate system when the flow of medium is likely to be very intermittent. This problem may be overcome by the use of feedback system. Wall growth is another commonly encountered practical difficulty in which the organism adheres to the inner surface of the reactor resulting, again, in an increase in heterogeneity.

Microbial Growth Kinetics

The immobilized cells are not subject to removal from the vessel but will consume substrate resulting in the suspended biomass concentration being lower than predicted. Wall growth may be limited by coating the inner surface of the vessel with Teflon.

Microbial Growth Kinetics

➤ A frequent observation in carbon and energy limited chemostats is that the biomass concentration at lower dilution rates is lower than predicted. This is attributed to the phenomenon of microorganisms utilizing a greater proportion of substrate for maintenance at lower dilution rates. Effectively the yield factor decreases at lower dilution rates.

➤ Bull (1974) has reviewed the major cause of deviation from basic chemostat theory.

Microbial Growth Kinetics

END

The basic chemostat may be modified in a number of ways, but the most common modifications are the addition of extra stages (vessels) and the feedback of biomass into the vessel.

Advances in Fermentation Technology

Lesson No.20

**Microbial
Growth
Kinetics:
Principles of
Growth
in
Continuous Systems**

Microbial Growth Kinetics

Continuous cultivation at steady rate is possible only when all factors contributing to the accumulation of biomass are exactly balanced by all factors contributing to the loss of biomass from the system:

$$\left(\begin{array}{l} \text{Cells added} \\ \text{to the system} \end{array} \right) - \left(\begin{array}{l} \text{Cells removed} \\ \text{from the system} \end{array} \right) + \left(\begin{array}{l} \text{Cells produced} \\ \text{through growth} \end{array} \right) - \left(\begin{array}{l} \text{Cells consumed} \\ \text{through death} \end{array} \right)$$

or

$$(FX_0/V) - (FX/V) + \mu X - aX = dX/dt \dots\dots (Eq.3)$$

F=Flow rate (liter/hour) in and outflow from fermenter;

V = Liquid volume (liters) in fermenter;

X₀ and X = cell masses (gl⁻¹) in the feed and fermenter;

μ=specific growth rate;

a=specific death rate (reciprocal hours);

dX/dt = rate of change in cell mass (gl⁻¹h⁻¹)

Microbial Growth Kinetics

At steady state

$$dX/dt = 0,$$

V and F are fixed,

a << μ, so aX is ignored,

And X₀ = 0, (because
Feed is sterile)

Hence at steady state
Eq. 3 is simplified as:

$$\mu = F/V = D \dots\dots (Eq.4)$$

Microbial Growth Kinetics

Specific growth rate of the population within the continuous fermenter is determined by the dilution rate, D .

Microbial Growth Kinetics

Chemostat is operated with sterile feed and not recycled hence $X_0=0$ and specific growth rate is equal to dilution rate ($\mu=D$). This is maintained by controlling the availability of a limiting nutrient through the addition of fresh medium.

Microbial Growth Kinetics

□ Limiting Nutrient Balance for a Chemostat

{Input-output-consumed} = Accumulation

or

$$DS_0 - DS - \mu X / Y_{x/s} = ds/dt \dots\dots (Eq.5)$$

$D = F/V$; S_0 and S are substrate concentration in the feed and fermenter, respectively;

X = dry cell mass in fermenter, $Y_{x/s}$ = yield coefficient;

dS/dt = rate of change of substrate concentration in the fermenter

If product formation other than cells occurs in chemostat at steady state equation 5 will be:

$$D(S_0 - S) = \mu X / Y_{x/s} \dots\dots (Eq.6)$$

substitution of equation 4 into this equation give:

$$X = Y_{x/s}(S_0 - S) \dots\dots (Eq.7)$$

Microbial Growth Kinetics

The overall growth yield is assumed to be dependent on the limiting nutrient concentration and independent of specific growth rate. Substituting and rearranging the previous equations:

$$D = d_c S / K_s + S \dots\dots (Eq.8)$$

d_c = critical dilution rate corresponding to the maximum specific growth rate (μ_{max})

Operation of the chemostat at dilution rates above D_c results in complete washout of the culture.

Microbial Growth Kinetics

Eq. 8 can be rearranged to

$$S = DK_s / (D_c - D) \dots \text{(Eq.8)}$$

Substitution into eq. 7 gives:

$$X = Y_{x/s} \{ S_0 - (DK_s / (D_c - D)) \}$$

END

Advances in Fermentation Technology

Lesson No.21

**Microbial
Growth
Kinetics:
Calculation
of
Growth Yield
in Chemostat**

Microbial Growth Kinetics

The yield substrate by $Y_{x/s}$, a ratio of the respective concentrations. Yields can be easily calculated by determining the production of dry cell mass over a given period of the cultivation and dividing by mass of carbon substrate consumed.

$Y_{x/s}$ = g dry cells produced / g substrate consumed

$Y_{x/ATP}$ = g dry cells produced / moles of ATP formed

Y_{x/O_2} = g dry cells produced / moles of O_2 consumed

Yield with respect to ATP synthesis or oxygen consumption is relatively constant for many organisms, e.g. the yield of cells per mole of ATP synthesized under conditions of energy substrate limitation and high growth rate = approximately $10 + 2$ g cells. Yields of cells per mole of ATP is not constant for all bacteria and is variable if the energy substrate is not growth limiting or the growth rate is lower than the maximum rate.

Microbial Growth Kinetics

□ Establishment of Steady-State Condition in a Chemostat

In terms of cell and substrate concentrations, steady-state condition can be ensured by allowing at least 4 changes of fermenter liquid volume.

Example: In a 2-litre chemostat with flow rate of (inlet and outlet) $F = 0.5$ L/h, and with dilution rate of $F/V = D = 0.25$ h⁻¹

The time necessary for 4 changes of medium volume = $4/D$ or $4/0.25$ h⁻¹ = 16h

Microbial Growth Kinetics

Steady-state will be established after 16 h of changing the growth conditions of a chemostat. Only then the overall growth yield can be determined as below:

$$Y_{x/s} = (X - X_0) / (S_0 - S)$$

X=g cells dry weight per liter of effluent medium.

X₀=g cells dry weight per liter of influent medium i.e. zero in sterile medium,

S=g substrate per liter of effluent medium,

S₀=g substrate per liter of influent medium

Microbial Growth Kinetics

Overall growth Yield is related maintenance and growth requirement for limiting substrates that act as energy sources:

$$1/Y_{x/s} = (m/m) + (1/Y_G)$$

m=specific rate of substrate uptake for cellular maintenance,

Y_{x/s}=overall yield,

Y_G=growth specific yield,

Microbial Growth Kinetics

m and Y_G can be estimated by plotting $(1/Y_{x/s})$ vs. $(1/\mu)$ on rectangular paper. If this gives a straight-line relationship, The intercept = $1/Y_G$; Slope of the line = m ($\mu = D$, in simple chemostat without cell recycle).

END

Advances in Fermentation Technology

Lesson No.22

Fermenter Design-1

Fermenter Design

□ Key points for Industrial Production of Bio-products

- As soon as possible (**initial start**)
- As fast as possible (**rate**)
- As much as possible (**concentration, yield**)
- As long as possible (**duration**)
- As cheap as possible (**cost**)
- As simple as possible (**ease of work**)
- As desirable as possible (**regulatory issues**)

Fermenter Design

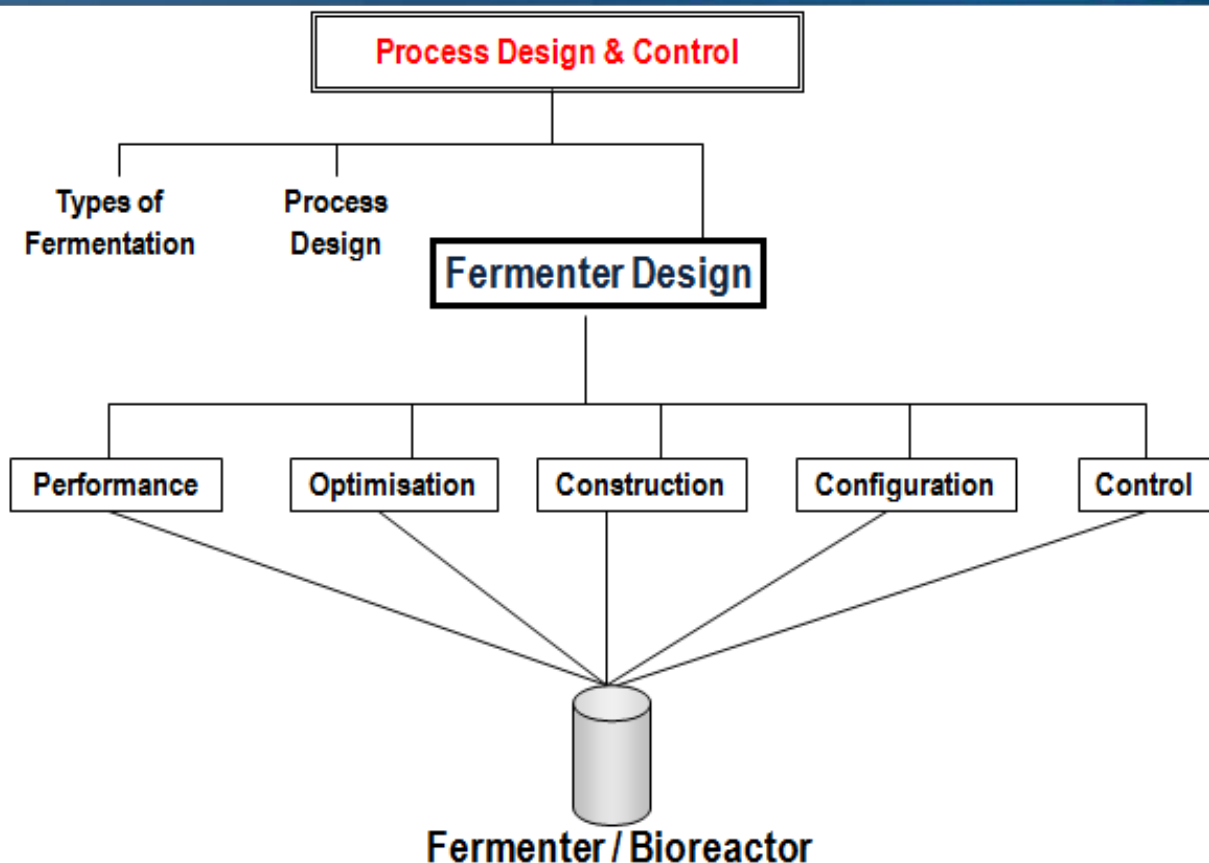

Fermenter Design

**Better productivity
of Biological
products depends
on:**

- ✓ **Strain
improvement**
- ✓ **Media
development**
- ✓ **Process Design &
Control**

END

Advances in Fermentation Technology

Lesson No.23

Fermenter Design-2

Fermenter Design

The **heart** of the Industrial fermentation process is the fermenter/bioreactor. The function of the fermenter or bioreactor is to provide a suitable environment in which an organism can efficiently produce a target product-the target product might be:

- **Cell biomass**
- **Metabolite**
- **Bioconversion Product**

Fermenter Design

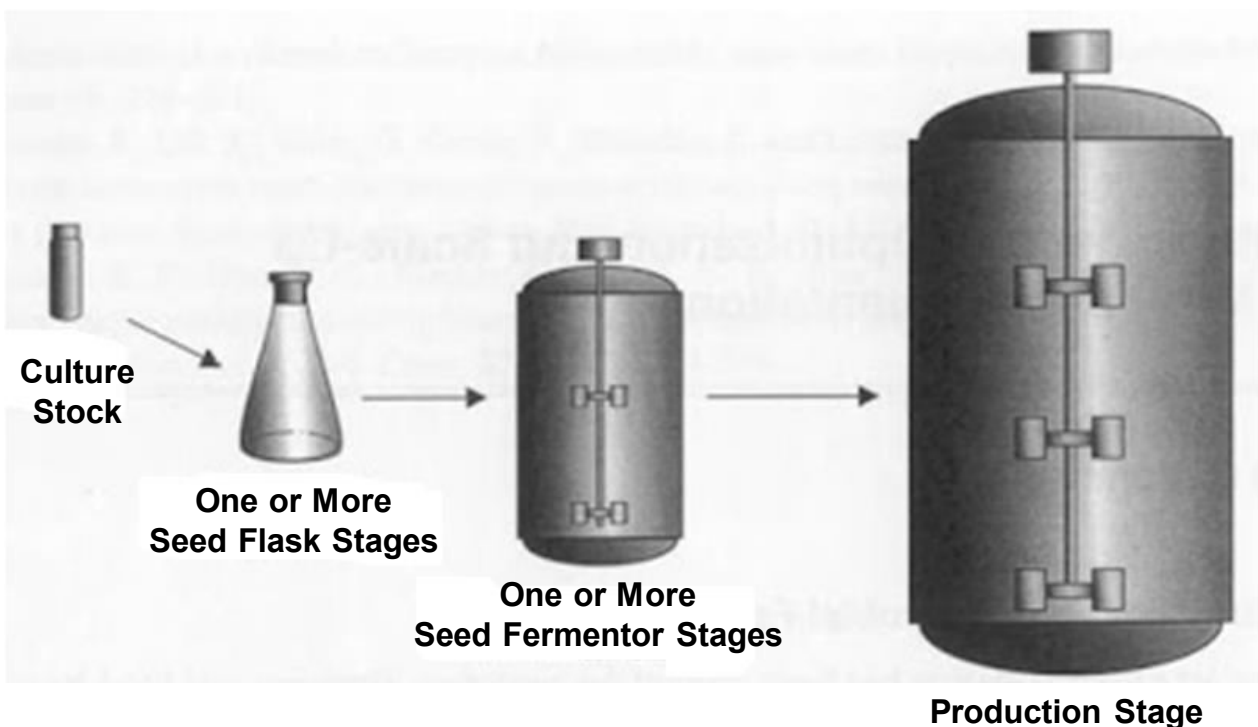

Fermenter Design

□ Range/Scale of Fermenter/Bioreactor

• Lab-scale Fermenters

Ex-situ sterilization but seed fermenter is not required for inoculums development, slants or flask cultures can be utilized.

• Pilot-scale Fermenters

In-situ sterilization but seed fermenter is not required for inoculums development, slants or flask cultures can be utilized.

• Industrial-scale Fermenters

In-situ sterilization and seed fermenter is required for inoculums development.

Fermenter Design



Fermenter Design

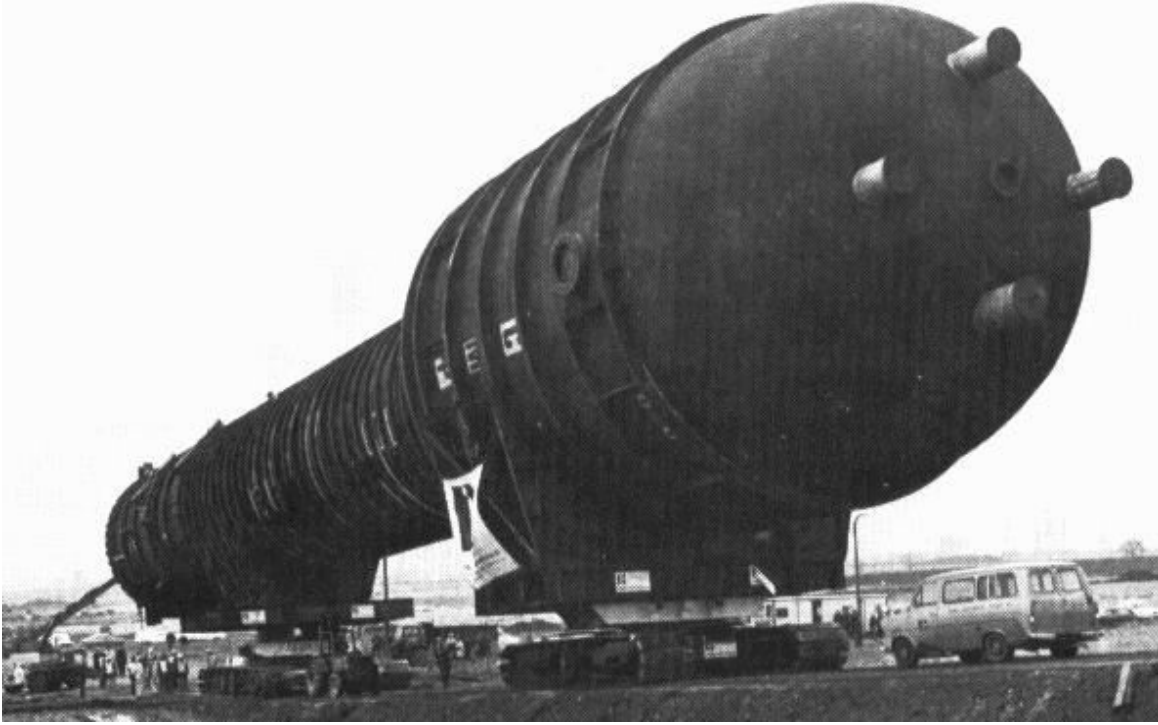

Industrial Fermenter:

The fermenter is 200' high and 25 ft dia

Fermenter Design

□ Commonly used Types of Fermenter

- Stirred tank reactor (STR)
- Air lift fermenter
- Fermenter with Venturi eductor
- Waldhof type fermenter
- Self priming fermenter
- Tower fermenter
- Koji fermenter

Fermenter Design

Some other types of Fermenter include:

- Packed bed
- Acetators and Cavitators
- Cyclone Column
- Cylindero-Conical Vessel
- Deep Jet Fermenter
- Rotating Disk Fermenters
- Paddle wheel reactor
- Basket reactor
- Spinfilter perfusion reactor
- Tray reactor
- Membrane Reactors
- Photo bioreactor

END

Advances in Fermentation Technology

Lesson No.24

Fermenter Design-3

Fermenter Design

☐ Accessories for a Fermenter:

- Baffle
- Sterile compressed air (at 1.5 to 3.0 atmospheres)
- Chilled water (12 to 15°C)
- Cold water (4°C)
- Hot water
- Steam (high pressure)

Fermenter Design

- Steam condensate
- Electricity
- Stand-by generator
- Drainage of effluents
- Motors
- Storage facilities for media components

END

Lesson No.25

Fermenter Design: General Requirements of Fermenters/ Bioreactors

Fermenter Design

There is no universal bioreactor. The general requirements of the bioreactor are as follows:

1. The vessel should be capable of being operated aseptically for a number of days and should be reliable in long-term operation and meet the requirements of containment regulations.
2. Adequate aeration and agitation should be provided to meet the metabolic requirements of the micro-organism. However, the mixing should not cause damage to the organism.
3. Power consumption should be as low as possible.
4. A system of temperature control should be provided.
5. A system of pH control should be provided.
6. Sampling facilities should be provided.

Fermenter Design

7. Evaporation losses from the fermenter should not be excessive.
8. The vessel should be designed to require the minimal use of labour in operation, harvesting, cleaning and maintenance.
9. Ideally the vessel should be suitable for a range of processes, but this may be restricted because of containment regulations.
10. The vessel should be constructed to ensure smooth internal surfaces, using welds instead of flange joints whenever possible.
11. The vessel should be of similar geometry to both smaller and larger vessels in the pilot plant or plant to facilitate scale-up.

Fermenter Design

12. The cheapest materials which enable satisfactory results to be achieved should be used.

13. There should be adequate service provisions for individual plants.

END

Lesson No.26

Fermenter Design: Aseptic Operation & Containment

Fermenter Design

- Aseptic operation involves protection against contamination and containment involves prevention of escape of viable cells from a fermenter or downstream equipments
- Containment guidelines were initiated during the 1970s. To establish the appropriate degree of containment which will be necessary to grow a micro-organism, it, and in fact the entire process, must be carefully assessed for potential hazards that could occur should there be accidental release. Different assessment procedures are used depending on whether or not the organism contains foreign DNA (genetically engineered). Once the hazards are assessed, an organism can be classified into a hazard group for which there is an appropriate level of containment.

Fermenter Design

Categorization of a process micro-organism and designation of its appropriate level of containment at research or industrial sites within the European Federation of Biotechnology

GILSP = Good Industrial Large Scale Practice

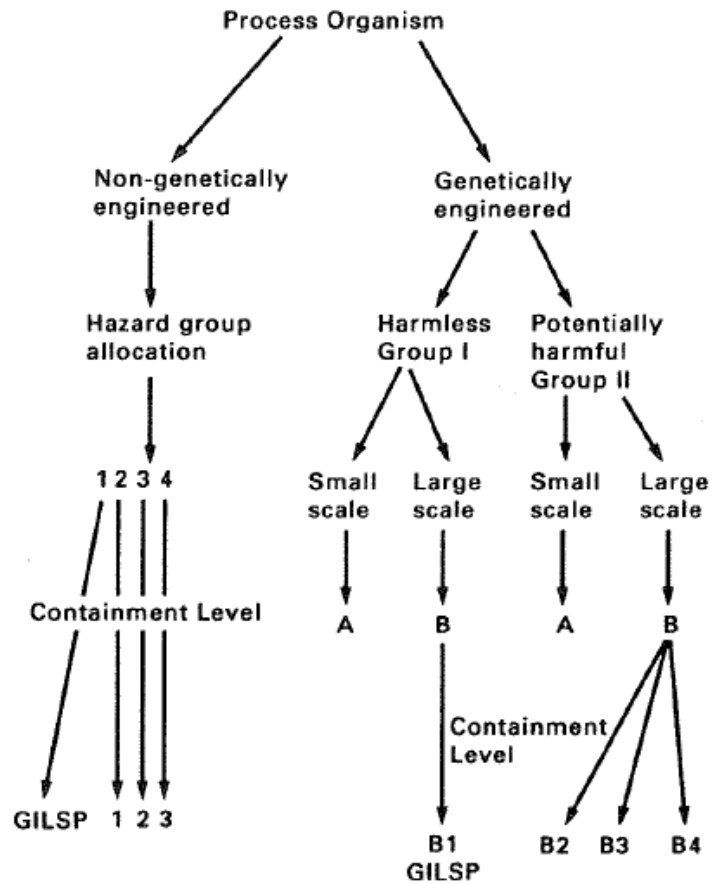

Fermenter Design

Risk such as those given by Collins (1992):

- 1. The known pathogenicity of the micro-organism.**
- 2. The virulence or level of pathogenicity of the microorganism are the diseases it causes mild or serious?**
- 3. The number of organisms required to initiate an infection.**

Fermenter Design

- 4. The routes of infection.**
- 5. The known incidence of infection in the community and the existence locally of vectors and potential reserves.**
- 6. The amounts or volumes of organisms used in the fermentation process.**

Fermenter Design

- 7. The techniques or processes used.**
- 8. Ease of prophylaxis and treatment.**

END

Lesson No.27

Fermenter Design: Aseptic Operation & Containment-2

Fermenter Design

Categorization of a process micro-organism and designation of its appropriate level of containment at research or industrial sites within the European Federation of Biotechnology

GILSP = Good Industrial Large Scale Practice

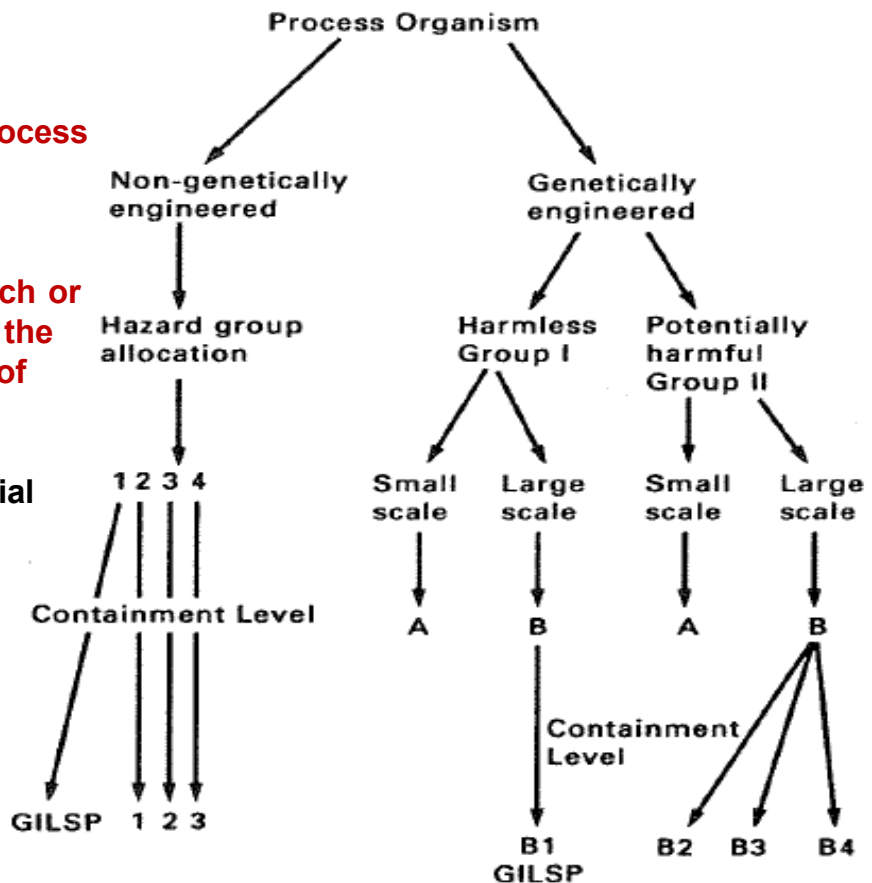

Fermenter Design

□ *Summary of safety precautions for biotechnological operations in the European Federation for Biotechnology (EFB) (Frommer et al., 1989)*

Procedures	GILSP*	Containment Category		
		1	2	3
Written instructions and code of practice	+	+	+	+
Biosafety manual	–	+	+	+
Good occupational hygiene	+	+	+	+
Good Microbiological Techniques (GMT)	–	+	+	+
Biohazard sign	–	+	+	+
Restricted access	–	+	+	+
Accident reporting	+	+	+	+
Medical surveillance	–	+	+	+

* Unless required for product quality, – , not required; +, required.

Fermenter Design

Procedures	GILSP*	Containment Category		
		1	2	3
<i>Primary containment: Operation and equipment</i>				
Work with viable micro-organisms should take place in closed systems (CS) , which minimize (m) or prevent (p) the release of cultivated micro-organisms	–	m	p	p
Treatment of exhaust air or gas from CS	–	m	p	p
Sampling from CS	–	m	p	p
Addition of materials to CS, transfer of cultivated cells	–	m	p	p
Removal of material, products and effluents from CS	–	m	p	p
Penetration of CS by agitator shaft and measuring devices	–	m	p	p
Foam-out control	–	m	p	p

m, minimize release. The level of contamination of air, working surface and personnel shall not exceed the level found during microbiological work applying Good Microbiological Techniques.
p, prevent release. No detectable contamination during work should be found in the air, working surfaces and personnel.

Fermenter Design

Procedures	GILSP*	Containment Category		
		1	2	3
<i>Secondary containment: Facilities</i>				
Protective clothing appropriate to the risk category	+	+	+	+
Changing/washing facility	+	+	+	+
Disinfection facility	-	+	+	+
Emergency shower facility	-	-	+	+
Airlock and compulsory shower facilities	-	-	-	+
Effluents decontaminated	-	-	+	+
Controlled negative pressure	-	-	-	+
HEPA filters in air ducts	-	-	+	+
Tank for spilled fluids	-	-	+	+
Area hermetically sealable	-	-	-	+

* Unless required for product quality, -, not required; +, required.

Fermenter Design

Once the organism has been allocated to a hazard group, the appropriate containment requirements can be applied (*as mentioned in the Table in previous slides*).

END

Lesson No.28

Fermenter Design: General Introduction of a Fermenter

Fermenter Design



• Detachable stirrer motor

Fermenter Design

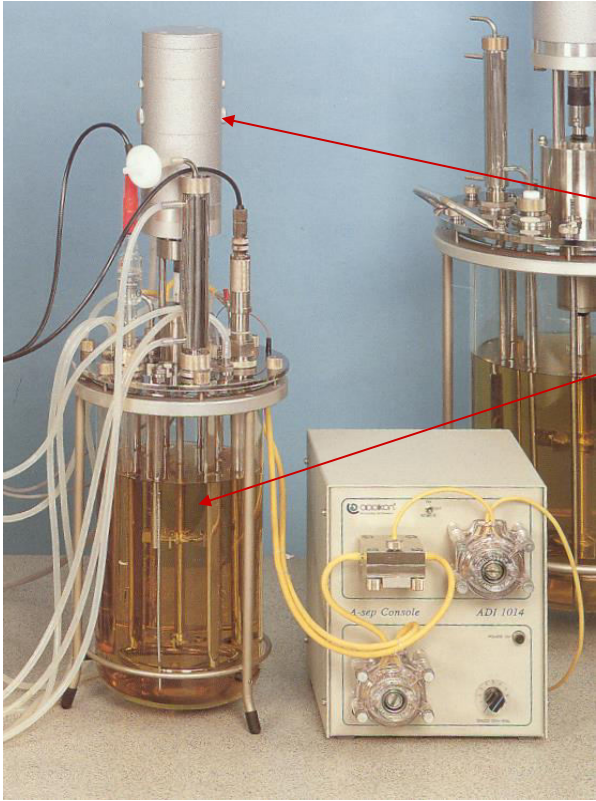

• Detachable stirrer motor

• Vessel

Fermenter Design



• Detachable stirrer motor

• Vessel

• pH/O₂ Electrodes

Fermenter Design

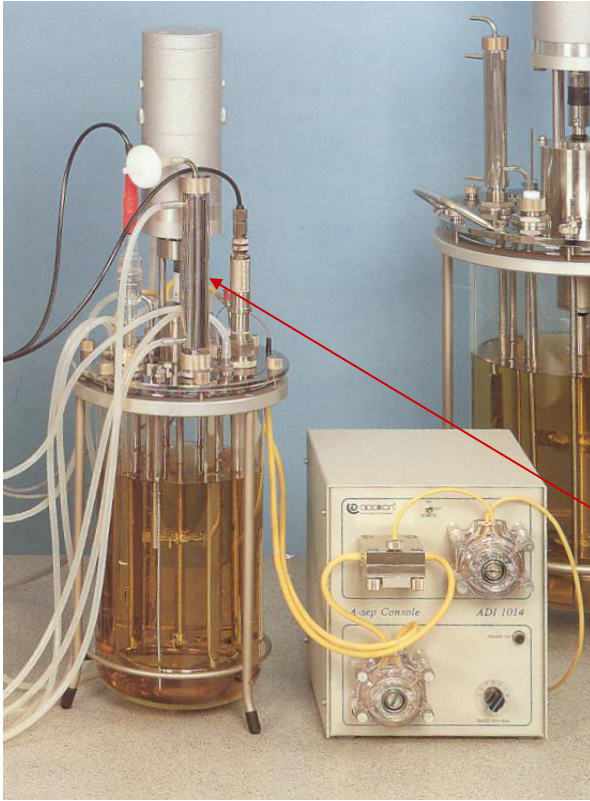

- Detachable stirrer motor
- Vessel
- pH/O₂ Electrodes
- Exhaust Gas Condenser

Fermenter Design

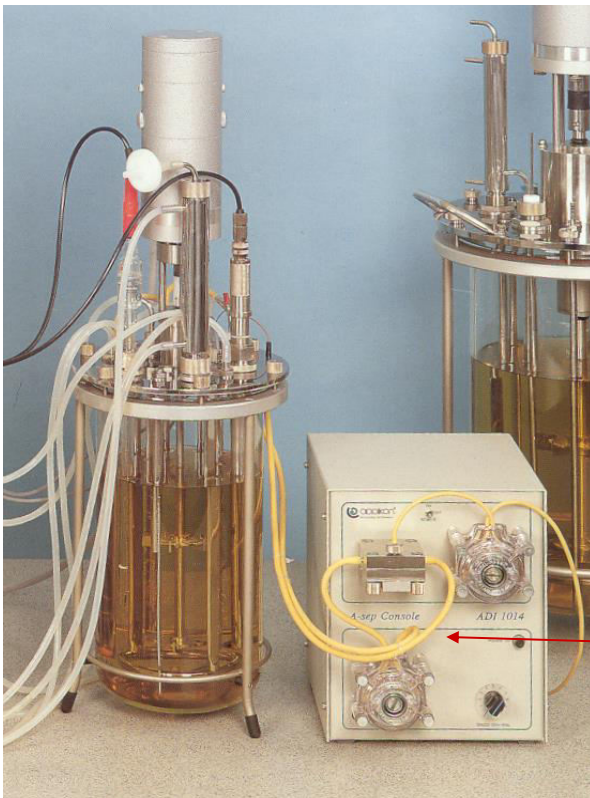

- Detachable stirrer motor
- Vessel
- pH/O₂ Electrodes
- Exhaust Gas Condenser
- Dialysis Unit (Not Usual)

Fermenter Design

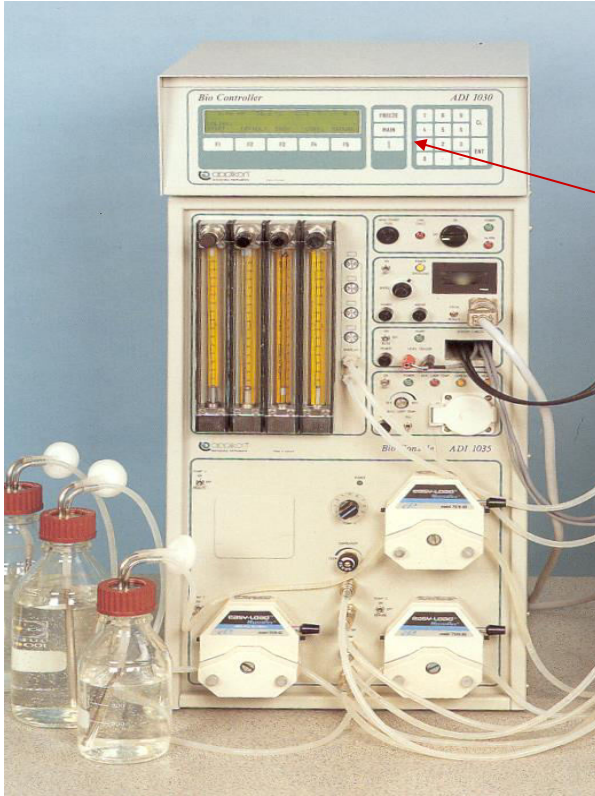

- ❖ Control Console Note:
 - Microprocessor logging & Control

Fermenter Design

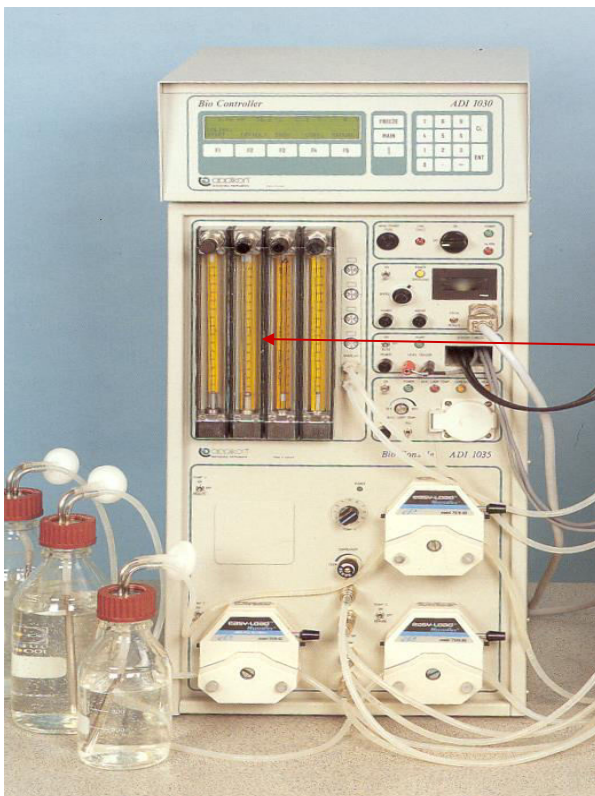

- ❖ Control Console Note:
 - Microprocessor logging & Control
 - Gas supply rotameters

Fermenter Design

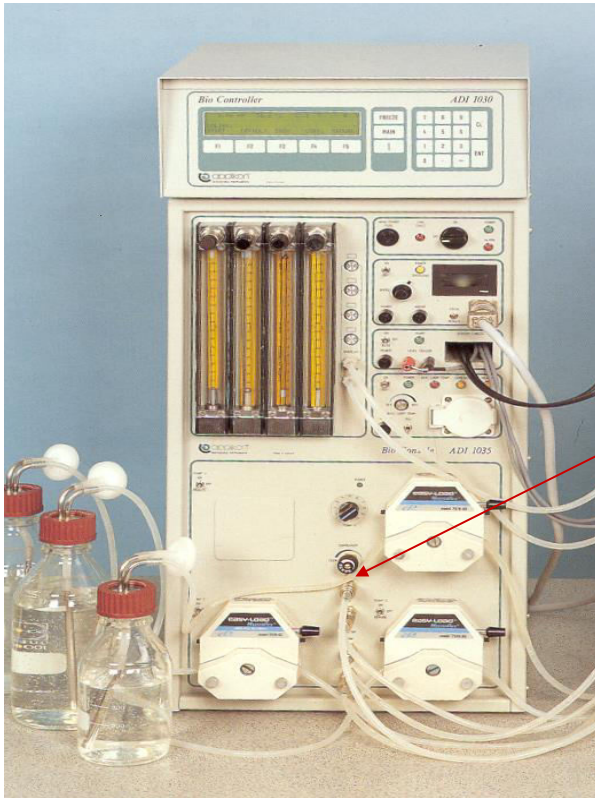

❖ Control Console Note:

- Microprocessor logging & Control
- Gas supply rotameters
- Pumps for pH control, antifoam, nutrient feed, etc.

Fermenter Design

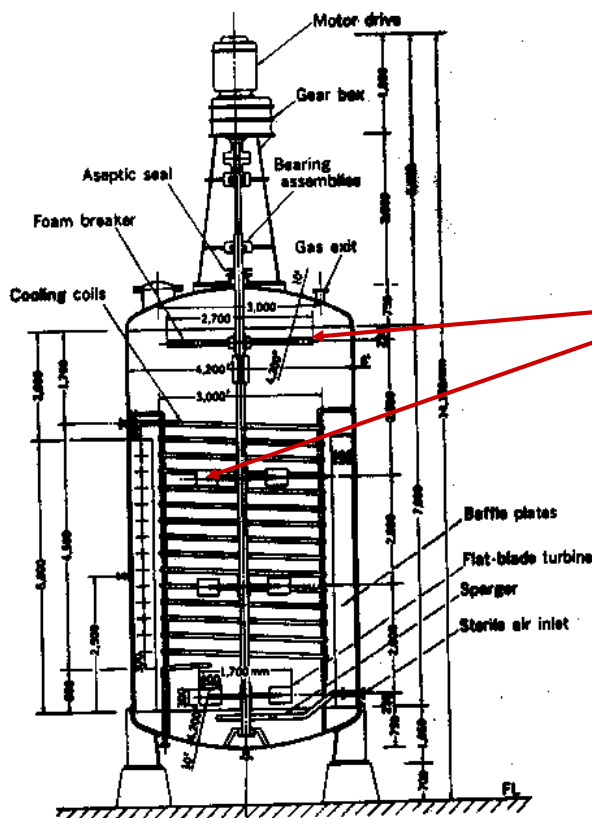

❖ Schematic representation of 100,000 L Production Factor with:

- Top drive agitators foam breakers

Fermenter Design

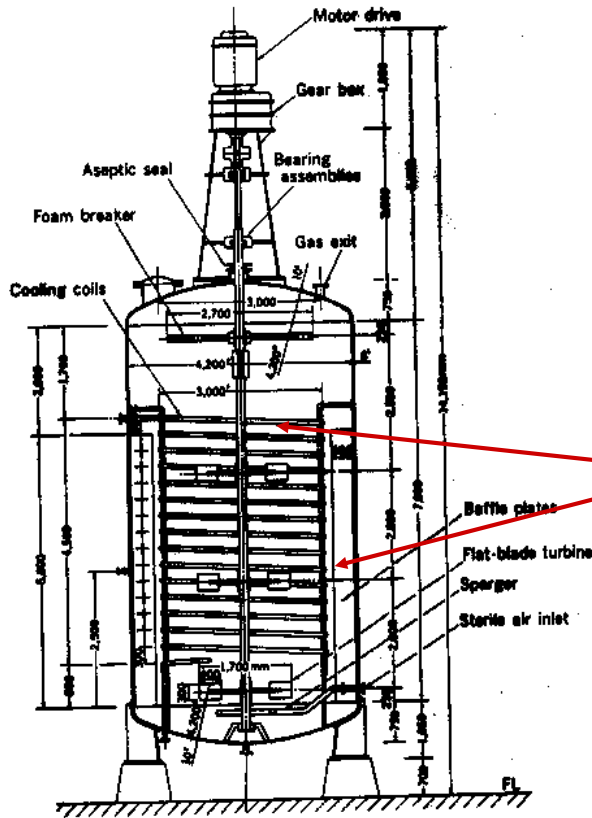

❖ Schematic representation of 100,000 L Production Factor with:

- Top drive agitators foam breakers

- Internal cooling coils and baffles

Fermenter Design

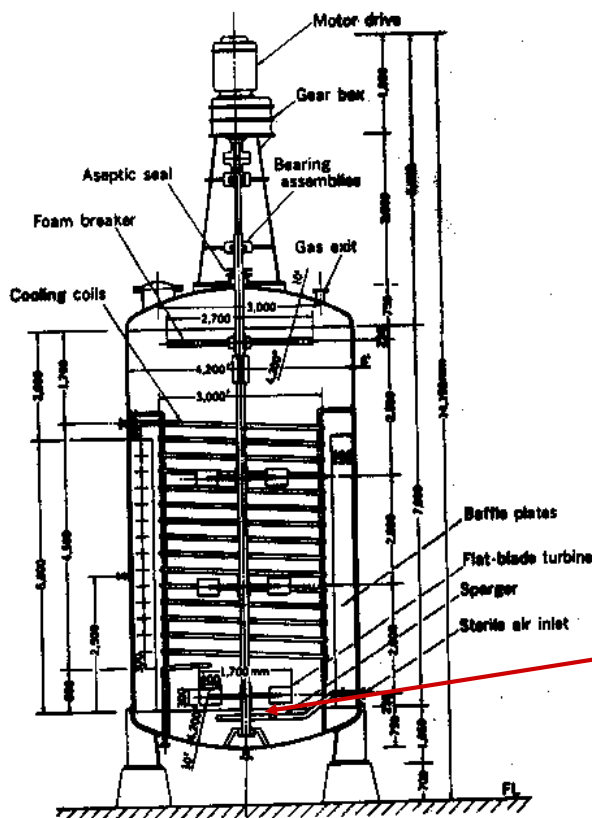

❖ Schematic representation of 100,000 L Production Factor with:

- Top drive agitators foam breakers

- Internal cooling coils and baffles

- Sparger (air input)

Fermenter Design

Therefore, basic features/accessories of a bioreactor associated for monitoring, control & record:

- An agitator system
- An oxygen delivery system
- A foam control system
- A temperature control system
- A pH control system
- A cleaning and sterilization system
- A sump and dump line system (only on pilot and Industrial Scale)

END

Advances in Fermentation Technology

Lesson No.29

Fermenter Design: Basic Parts of a Stirred Fermenter

Fermenter Design

1. *Body vessel*

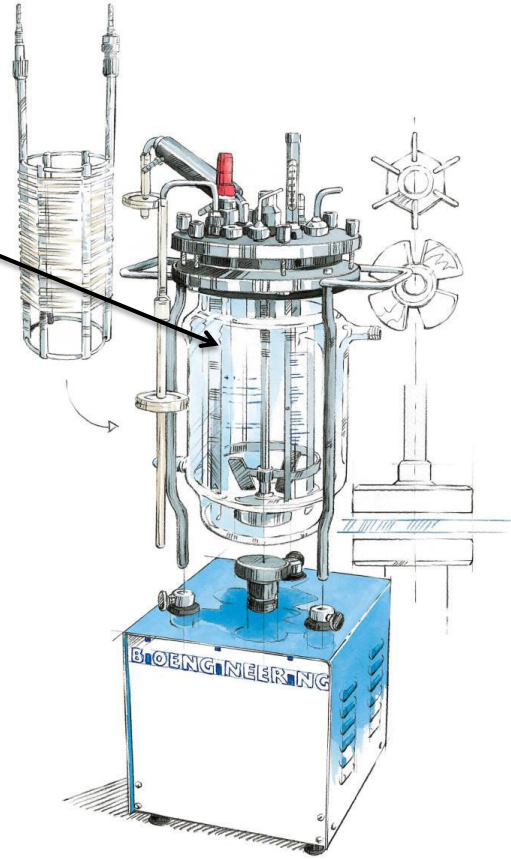

Fermenter Design

1. *Body vessel*

2. *Agitator*

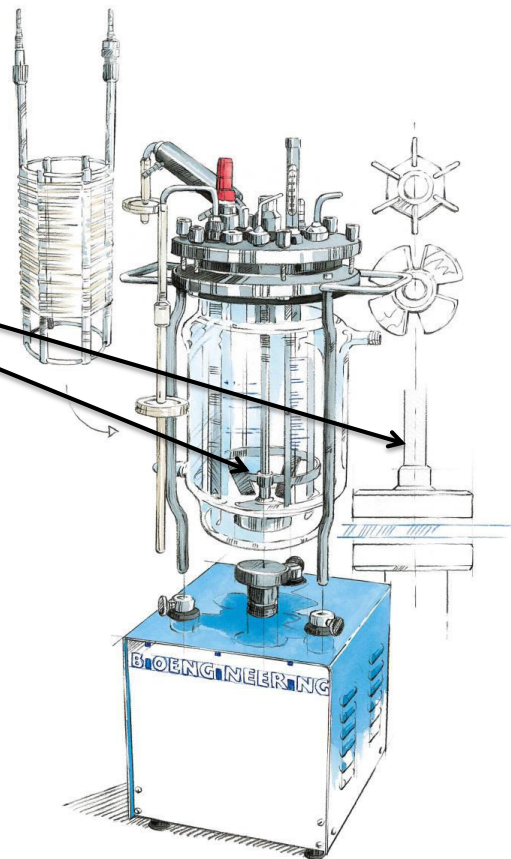

Fermenter Design

1. Body vessel
2. Agitator
3. Sparger

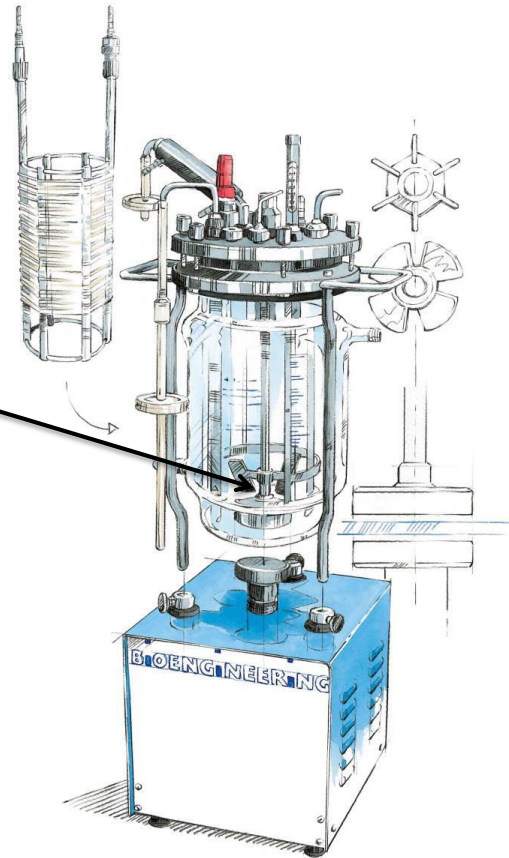

Fermenter Design

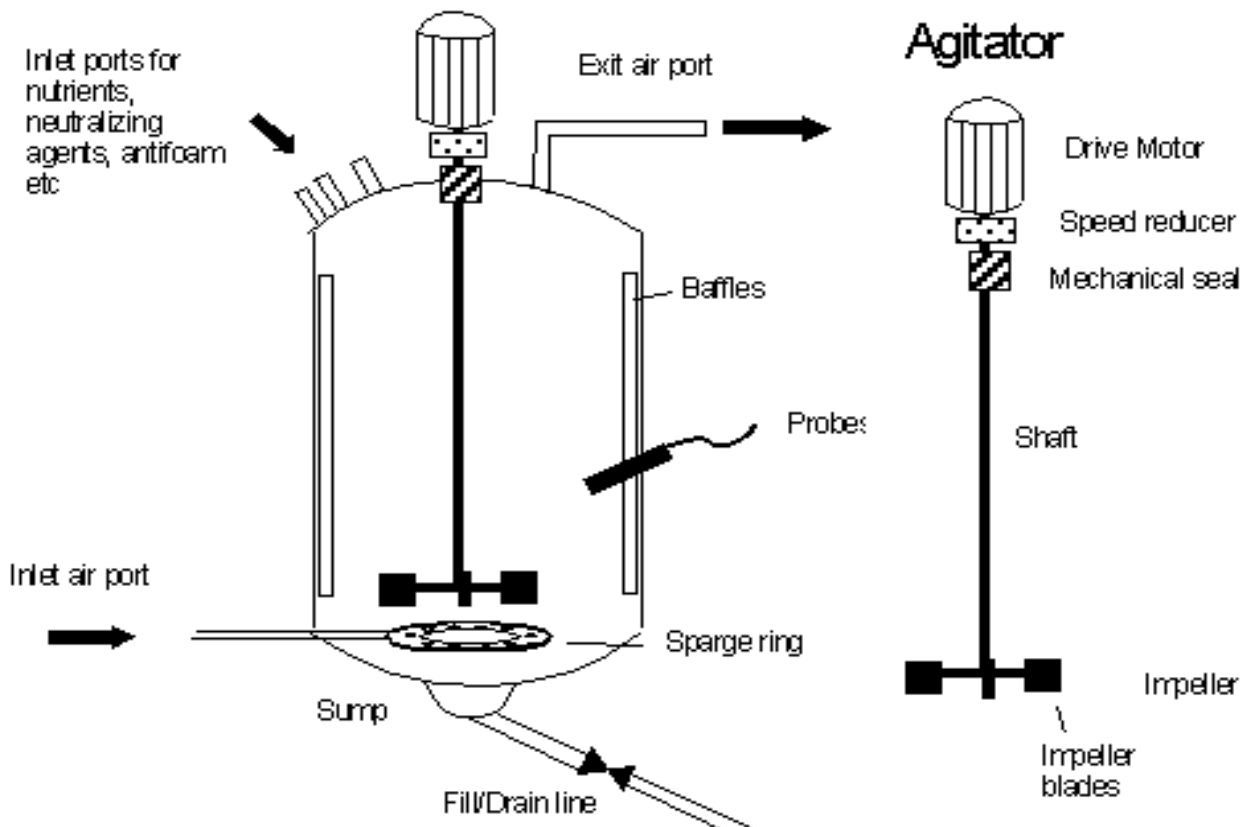

Fermenter Design

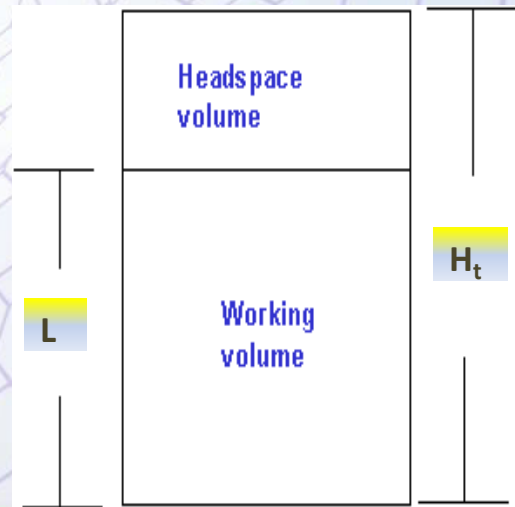

END

Advances in Fermentation Technology

Lesson No.30

**Fermenter
Design:
Body
Construction**

Fermenter Design

□ Schematic representation of a fermenter with one multi-blade impeller

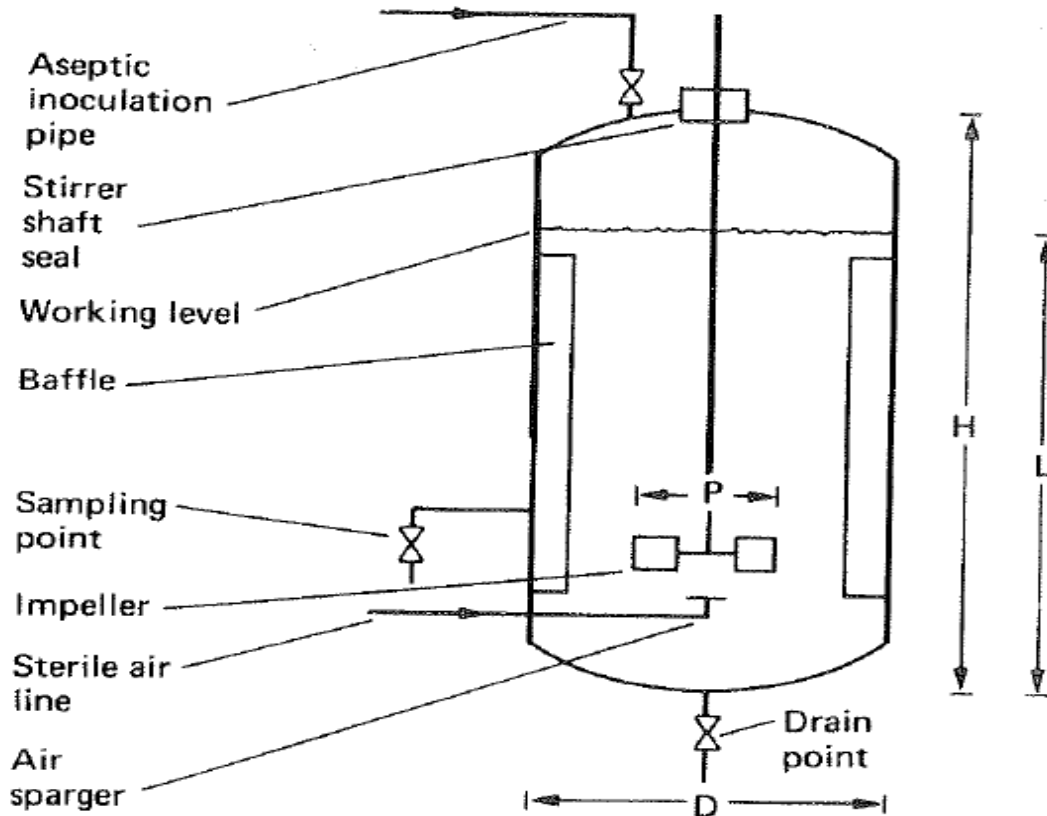

Fermenter Design

□ Details of geometrical ratios of Fermenters with single multi-blade impellers

Dimension	Steel and Maxon (1961)	Wegrich and Shurter (1963)	Blakeborough (1967)
Operating volume	250L	12L	--
Liquid height (L)	55cm	27cm	--
L/D (tank diameter)	0.72	1.1	1.0 – 1.5
Impeller diameter (P/D)	0.4	0.5	0.33
Baffle width/D	0.10	0.08	0.08 – 0.10
Impeller height/D	--	--	0.33

Fermenter Design

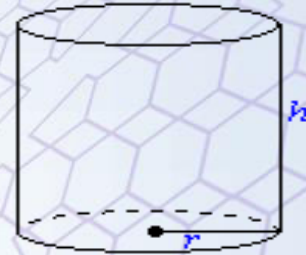

Volume of a cylinder: $V = \pi r^2 h$

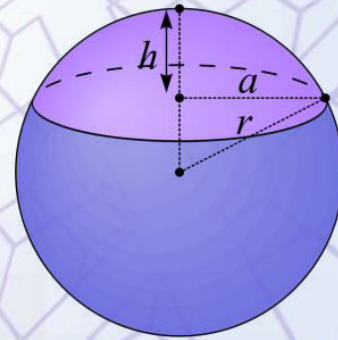

$$V = \frac{\pi h}{6} (3a^2 + h^2)$$

END

Advances in Fermentation Technology

Lesson No.31

**Fermenter
Design:
with
Multi-impeller**

Fermenter Design

Details of geometrical ratios of Fermenters with multi-blade impellers

Dimension	Jackson (1958)	Aiba <i>et al.</i> , (1973)	Paca <i>et al.</i> , (1976)
Operating volume	--	100,000 L	170 L
Liquid height (L)	--	--	150cm
L/D (tank diameter)	--	--	1.7
Impeller diameter (P/D)	0.34-0.5	0.4	0.33
Baffle width/D	0.08-0.1	0.095	0.098
Impeller height/D	0.5	0.25	0.37
P/V	0.5-1.0	--	0.74
P/W	0.5-1.0	0.85	0.77
P/Y	0.5-1.0	0.85	0.77
P/Z	--	2.1	0.91
H/D	1.0 -1.6	2.2	2.95

Fermenter Design

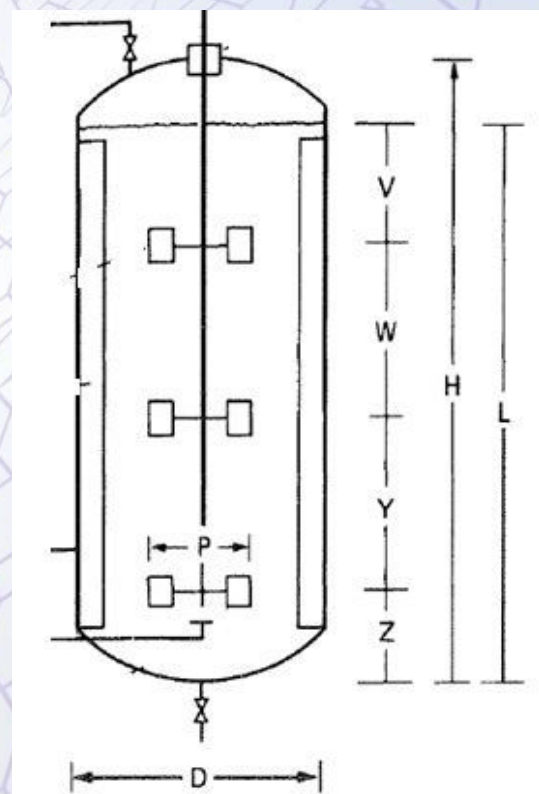

END

Lesson No.32

Fermenter Design: Construction Materials

Fermenter Design

□ Construction Materials

In fermentations with strict aseptic requirements it is important to select materials that can **withstand repeated steam sterilization cycles**. On a small scale (1 to 30 L) it is possible to use **glass and/or stainless steel**. Glass is useful because it gives smooth surfaces, is non-toxic, corrosion proof and it is usually easy to examine the interior of the vessel. Two basic types of fermenter are used at **lab scale**:

1. A glass vessel with a round or flat bottom and a top flanged carrying plate. The large glass containers originally used were borosilicate battery jars (Brown and Peterson, 1950). All vessels of this type have to be sterilized by autoclaving. Cowan and Thomas (1988) state that the **largest practical diameter** for glass fermenters is **60 cm**.

Fermenter Design

2. A glass cylinder with stainless-steel top and bottom plates . These fermenters may be sterilized *in situ*, but **30 cm** diameter is the upper size limit to safely withstand working pressures (**Solomons, 1969**). Vessels with two stainless steel plates cost approximately 50% more than those with just a top plate.

END

Advances in Fermentation Technology

Lesson No.33

Fermenter Design: Pilot Scale & Industrial Scale Fermenters

Fermenter Design

- Pilot-scale and industrial scale vessels are normally constructed of stainless steel or at least have a stainless-steel cladding to limit corrosion.
- The American Iron and Steel Institute (AISI) states that steels containing less than 4% chromium are classified as **steel alloys** and those containing more than 4% are classified as **stainless steels**. Mild steel coated with glass or phenolic epoxy materials has occasionally been used (Gordon *et al.*, 1947; Fortune *et al.*, 1950; Buelow and Johnson, 1952; Irving, 1968).
- Wood, Plastic and concrete have been used when contamination was not a problem in a process (Steel and Miller, 1970).

Fermenter Design



Fermenter Design

❖ The corrosion resistance of stainless steel is thought to depend on the existence of a thin **hydrous oxide film** on the surface of the metal. The composition of this film varies with different steel alloys and different manufacturing process treatments such as **rolling, pickling or heat treatment**. The film is stabilized by chromium and is considered to be continuous, non-porous, insoluble and self healing. If damaged, the film will repair itself when exposed to air or an oxidizing agent (Cubberly *et al.*, 1980).

❖ The minimum amount of chromium needed to resist corrosion will depend on the corroding agent in a particular environment, such as acids, alkalis, gases, soil, salt or fresh water. Increasing the chromium content enhances resistance to corrosion, but only grades of steel containing at least **10 to 13% chromium** develop an effective film.

Fermenter Design

The inclusion of **nickel in high percent chromium steels** enhances their resistance and improves their engineering properties. The presence of **molybdenum improves the resistance of stainless steels to solutions of halogen salts** and pitting by chloride ions in brine or sea water. Corrosion resistance can also be improved by **tungsten, silicone** and other elements.

END

Lesson No.34

Fermenter Design: Grading quality of Construction Material

Fermenter Design

AISI Grade 316 steels which contain 18% chromium, 10% nickel and 2-2.5% molybdenum are now commonly used in fermenter construction.

In a citric acid fermentation where the pH may be 1 to 2 it will be necessary to use a stainless steel with 3-4% molybdenum (AISI grade 317) to prevent leaching of heavy metals from the steel which would interfere with the fermentation.

AISI Grade 304, which contains 18.5% chromium and 10% nickel, is now used extensively for brewing equipment.

Fermenter Design

AISI	UNS	C	S	Si	Cr	Ni	Cu	Mo	Nb
302B	S30215	0.03 Max.	0.03 Max.	2.0 3.0	17.0 19.0	8.0 10.0	.50 Max.	.50 Max.	-----
303L	S30300	0.03 Max.	.150 .300	1.0 Max.	17.0 19.0	8.0 10.0	.50 Max.	.50 Max.	-----
304L	S30403	0.03 Max.	.030 Max.	1.0 Max.	17.0 19.0	8.0 10.0	.50 Max.	.50 Max.	-----
304Cu	S30430	0.12 Max.	.030 Max.	1.0 Max.	17.0 19.0	8.0 10.0	3.0 4.0	.50 Max.	-----
316L	S31603	0.03 Max.	.030 Max.	1.0 Max.	16.0 18.0	10.0 14.0	.50 Max.	2.00 3.00	-----
316Cb	S31640	0.03 Max.	0.03 Max.	1.0 Max.	16.0 18.0	10.0 14.0	.50 Max.	2.00 3.00	.40 .60
317L	S31703	0.03 Max.	.030 Max.	1.0 Max.	18.0 20.0	11.0 15.0	.50 Max.	3.00 4.00	-----
321L	S32100	0.03 Max.	.030 Max.	1.0 Max.	17.0 19.0	9.0 12.0	.50 Max.	.50 Max.	.40 .60

Fermenter Design

- The thickness of the construction material will increase with scale.
- At **300,000-400,000 L** capacity, **7-mm** plate may be used for the side of a vessel and **10 mm plate** for the top and bottom, which should be hemispherical to withstand pressures.

END

Lesson No.35

Fermenter Design: Seals & O Rings

Fermenter Design

- ✓ Reliable aseptic seal is made between glass and glass, glass and metal or metal and metal joints such as between a fermenter vessel and a detachable top or base plate.
- ✓ With glass and metal, a seal can be made with a compressible gasket, a lip seal or an 'O' ring. With metal to metal joints only an 'O' ring is suitable. This is placed in a groove, machined in either the end plate, the fermenter body or both.
- ✓ This seal ensures that a good liquid-and/or gas-tight joint is maintained in spite of the glass or metal expanding or contracting at different rates with changes in temperature during a sterilization cycle or an incubation cycle.
- ✓ **Nitryl or butyl rubbers** are normally used for these seals as they will withstand fermentation process conditions. These rubber seals have a finite life and should be checked regularly for damage or perishing.

Fermenter Design

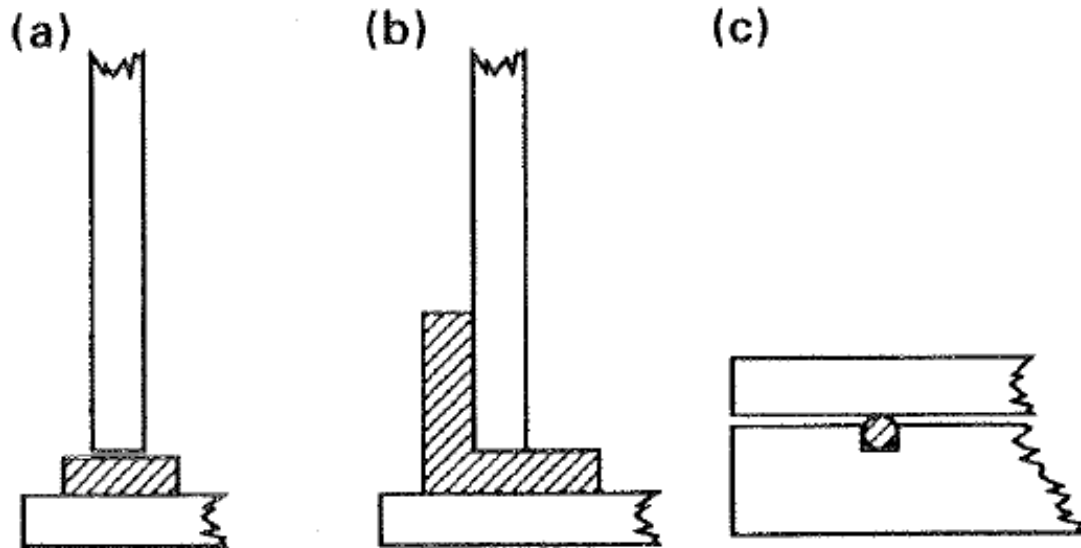

Joint seals for glass-glass, glass-metal and metal-metal; (a) **gasket**; (b) **lip seal**; (c) **'O' ring in groove**.

Fermenter Design

Main Seals

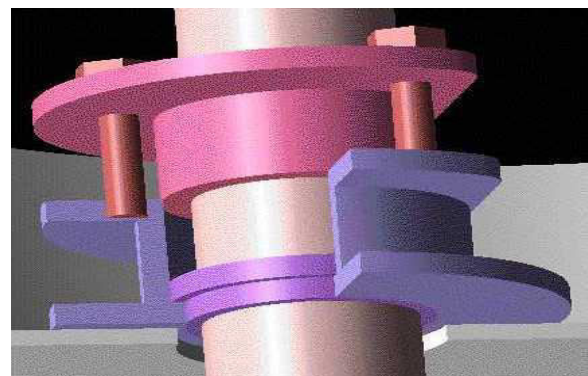
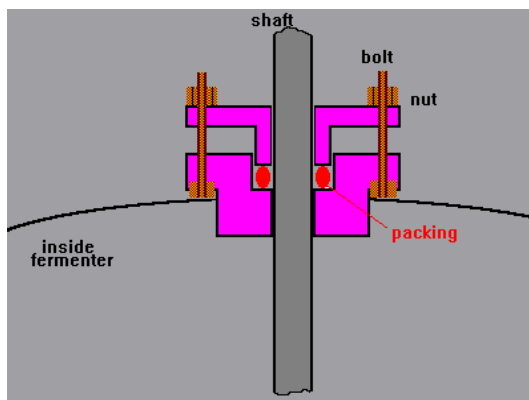

Fermenter Design

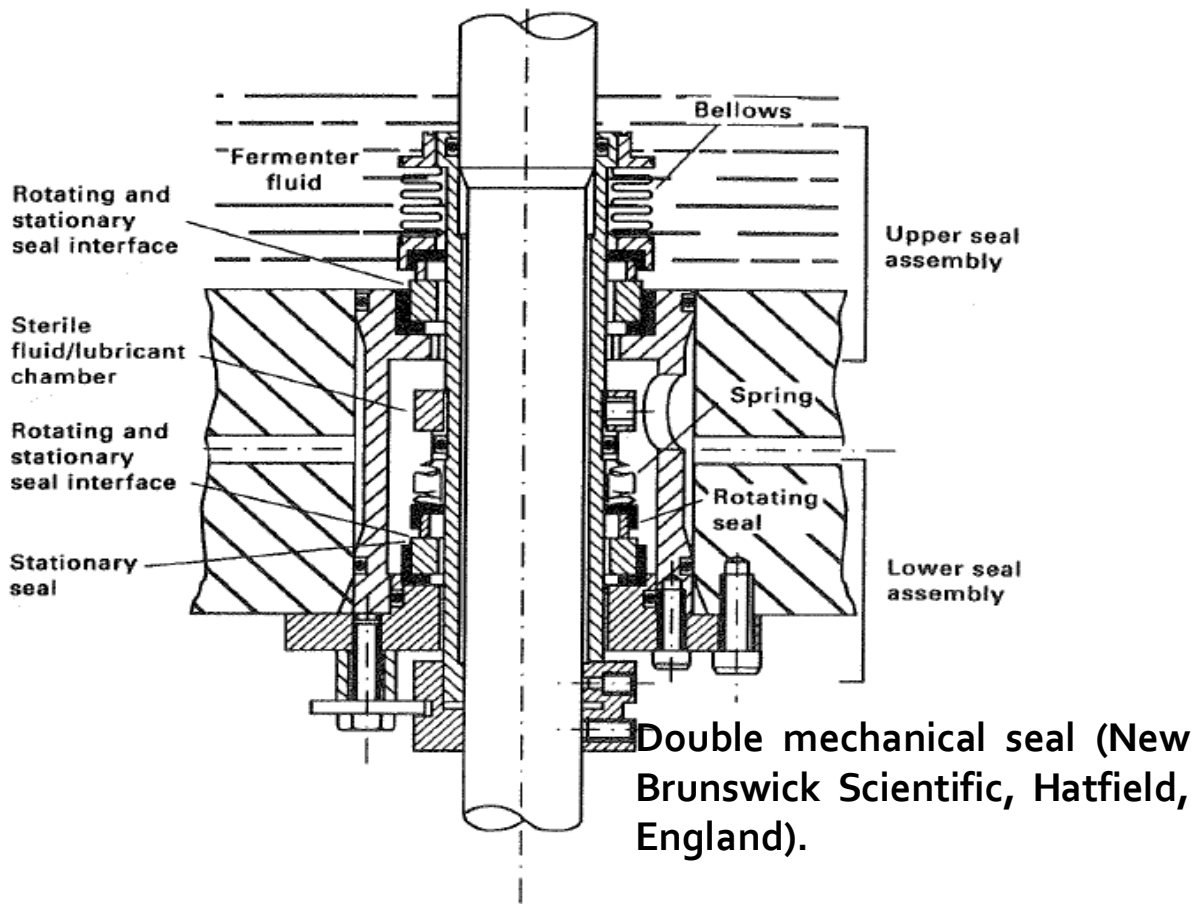

Fermenter Design

Without Main Seal



END

Lesson No.36

Fermenter Design: Basic Features of a Stirred Tank Bioreactor: Agitation System-1

Fermenter Design

The function of the agitation system is to

- provide good mixing and thus increase mass transfer rates through the bulk liquid and bubble boundary layers.
- provide the appropriate shear conditions required for the breaking up of bubbles.

The agitation system consists of the agitator and the baffles.

The baffles are used to break the liquid flow to increase turbulence and mixing efficiency.

Fermenter Design

Agitator

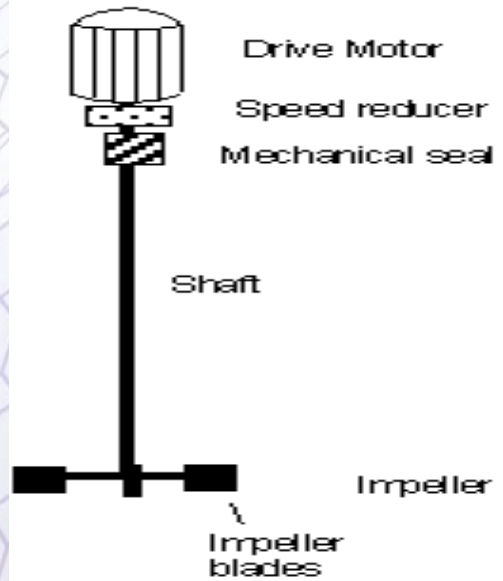

END

Advances in Fermentation Technology

Lesson No.37

Fermenter Design:

**Basic Features of a
Stirred Tank Bioreactor:
Agitation System-2**

Fermenter Design

Number of impellers will depend on the height of the liquid in the reactor. Each impeller will have between 2 and 6 blades. Most microbial fermentations use a Rushton turbine impeller.

A single phase agitator drive motor can be used with small reactors. However for large reactors, a 3 phase motor should be used. The latter will tend to require less current and therefore generate less heat.

Speed control or speed reduction devices are used to control the agitation speed.

Fermenter Design



Fermenter Design

The impeller shaft can enter from the **bottom** of the tank or from the **top**. A top entry impeller ("overhung shaft") is more expensive to install as the motor and the shaft will need to be structurally supported:

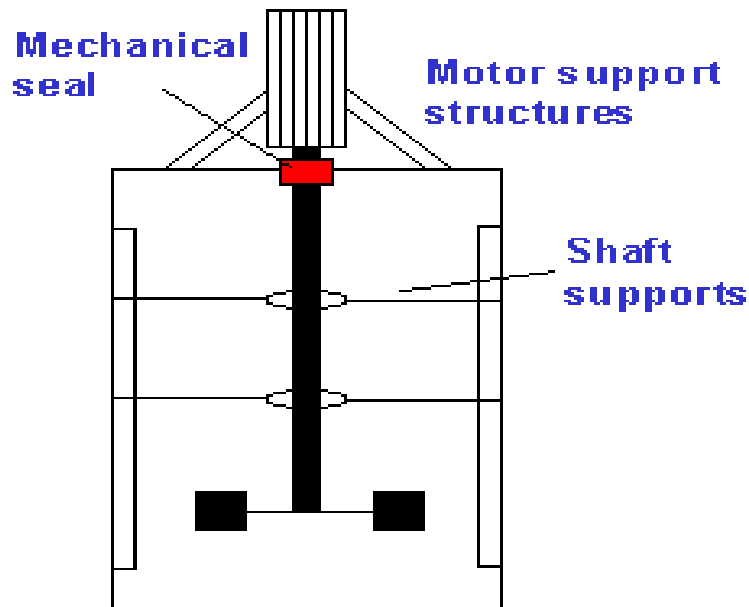

Fermenter Design

A reactor with bottom entry impeller however will need higher maintenance due to damage of the seal by particulates in the medium and by medium components that crystallize in the seal when reactor is not in use.

Fermenter Design

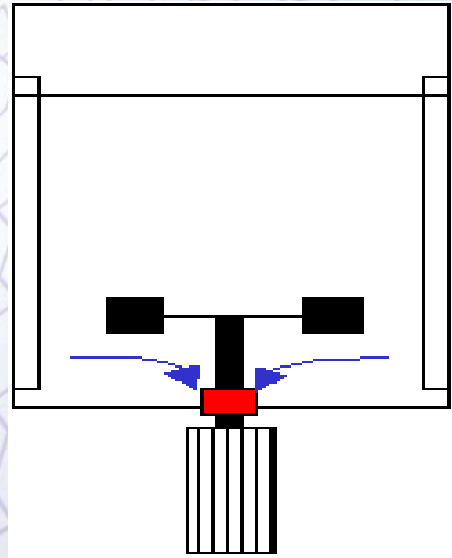

Fermenter Design

Bottom entry agitators tend to require more maintenance than top entry impellers due to the formation of crystals and other solids in the seals.

END

Lesson No.38

Fermenter Design: Agitator design and Operation-1

Fermenter Design

Baffles

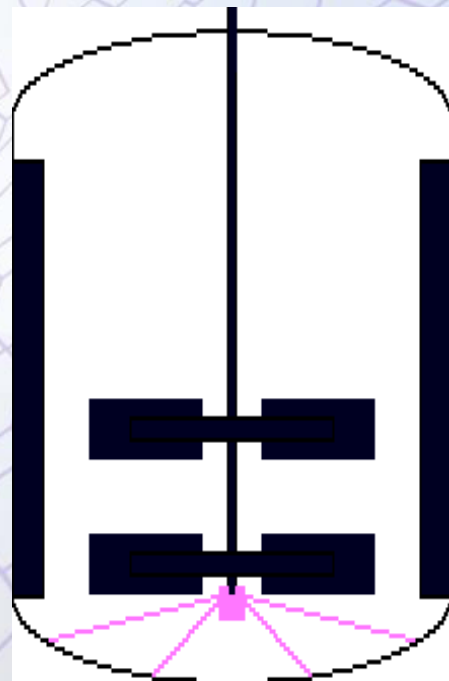

Fermenter Design

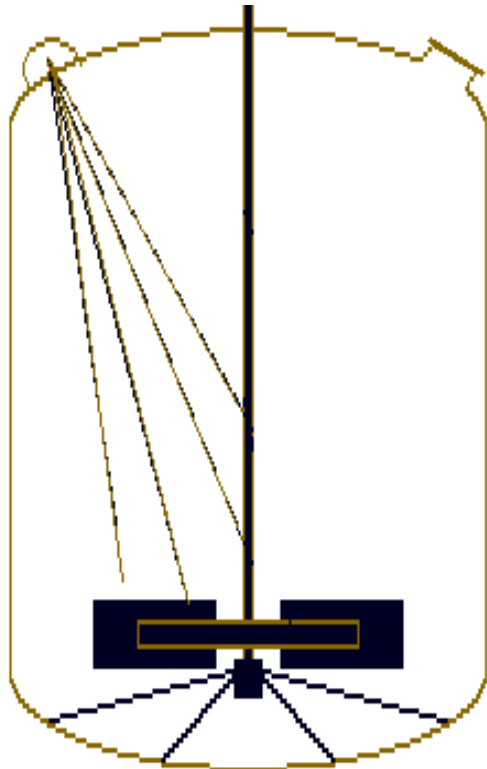

Only top bolt slot is shown

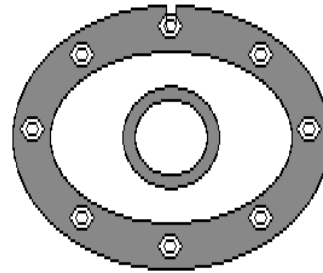

Fermenter Design

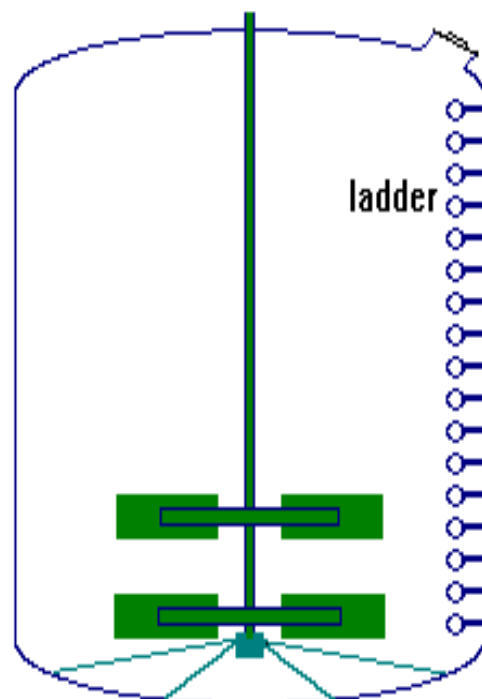

END

Lesson No.39

Fermenter Design: Agitator design and Operation-2

Fermenter Design

- ❑ Agitators are classified as having radial flow or axial flow characteristics.
- ❑ With radial flow mixing, the liquid flow from the impeller is initially directed towards the wall of the reactor; i.e. along the radius of the tank.
- ❑ With axial flow mixing, the liquid flow from the impeller is directed downwards towards the base of the reactor, i.e. in the direction of the axis of the tank.
- ❑ Radial flow impellers are primarily used for gas-liquid contacting (such as in the mixing of sparged bioreactors) and blending processes.
- ❑ Axial flow impellers provide more gentle but efficient mixing and are used for reactions involving shear sensitive cells and particles.

Fermenter Design

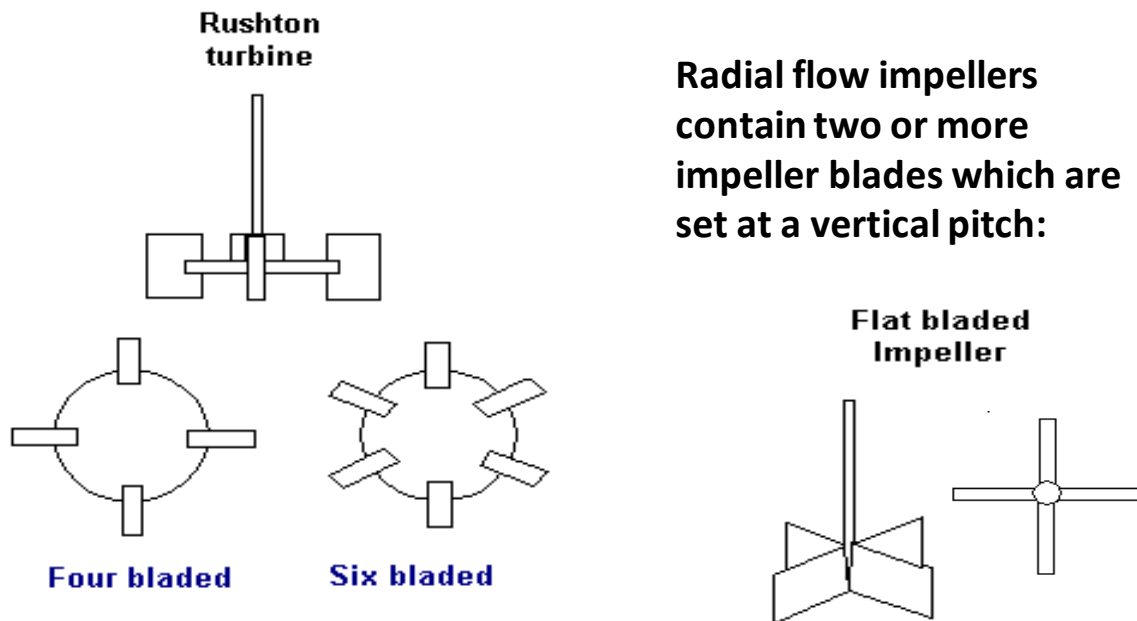

Fermenter Design

The liquid flow from the blades is directed towards the walls of the reactor; i.e. along the radius of the tank.

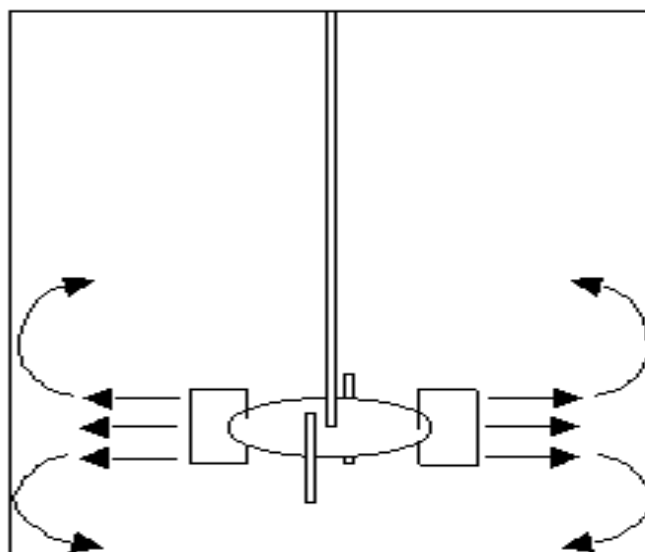

With radial flow impellers, the liquid is pushed towards the wall of the tank; that is, along the radius of the reactor

Fermenter Design

Radial flow mixing is not as efficient as axial flow mixing.

For radial flow impellers, a much higher input of energy is required to generate a given level of flow.

Radial flow impellers do and are designed to, generate high shear conditions. This is achieved by the formation of vortices in the wake of the impeller.

Fermenter Design

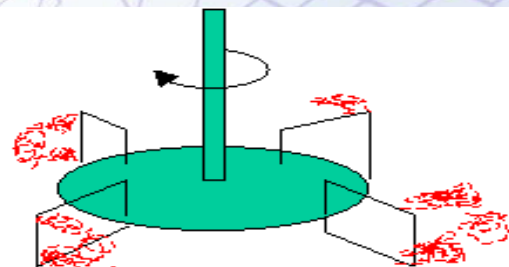

Eddies form in the wake of the impeller blades and generate a high shear environment

END

Lesson No.40

Fermenter Design: Agitator design and Operation-3

Fermenter Design

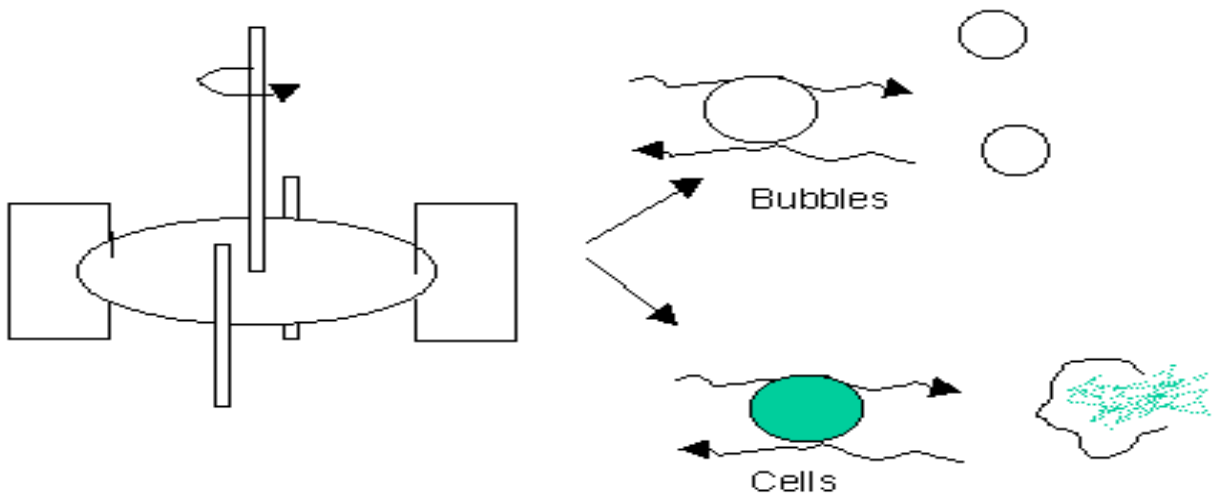

Fermenter Design

The high shear is effective at breaking up bubbles. For this reason, radial flow impellers are used for the culture of aerobic bacteria.

High shear can also damage shear sensitive materials such as crystals and precipitates and shear sensitive cells such as filamentous fungi and animal cells.

FND

www.vuCTn.com

BIO204 Complete MERGED

PPT Slides 1 TO 91

Regards : Zarva Chaudhary

Merged File date 2021

Admin:

*** Zarva Chaudhary ***

Chandhary Moazzam

*** Laiba Maki ***

Lesson No.41

Fermenter Design: Agitator design and Operation-4

Fermenter Design

The most commonly used agitator in microbial fermentations is the **Rushton turbine**.

Like all radial flow impellers, the Rushton turbine is designed to provide the high shear conditions required for breaking bubbles and thus increasing the oxygen transfer rate.

The Rushton turbine has 4 or 6 blades which are fixed onto a disk.

The diameter of the Rushton turbine should be $\frac{1}{3}$ of the tank diameter.

Fermenter Design

A Rushton turbine is often referred to as a disk turbine.

The disk design ensures that most of the motor power is consumed at the tips of the agitator and thus maximizing the energy used for bubble shearing.

Fermenter Design

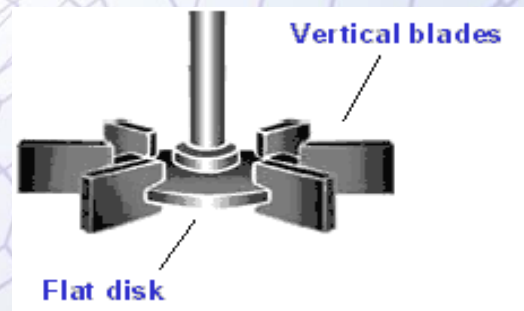

END

Lesson No.42

Fermenter Design: Agitator design and Operation: Axial Flow Impellers-1

Fermenter Design

Axial flow mixing is considerably more energy efficient than radial flow mixing.

They are also more effective at lifting solids from the base of the tank.

Axial flow impellers have low shear properties. The angled pitch of the agitators coupled with the thin trailing edges of the impeller blades reduces formation of eddies in the wake of the moving blades.

Fermenter Design

Axial flow impeller blades are pitched at an angle and thus direct the liquid flow towards the base of the tank. Examples of axial flow impellers are marine impellers and hydrofoil impellers.

Fermenter Design

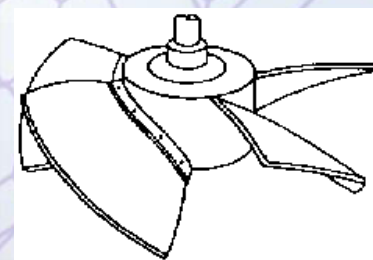
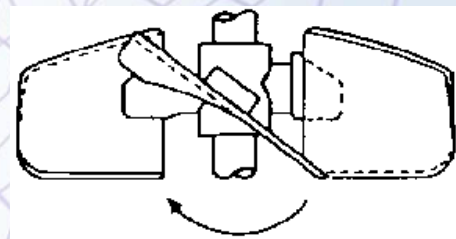

Lesson No.43

Fermenter Design: Agitator design and Operation: Axial Flow Impellers-2

Fermenter Design

Axial flow impellers are used for mixing shear sensitive processes such as crystallization and precipitation reactions.

They are also used widely in the culture of animal cells.

Their low shear characteristics generally makes them ineffective at breaking up bubbles and thus unsuitable for use in aeration of bacterial fermentations.

Fermenter Design

With the use of Axial Flow Impellers, the radial resultant flow pattern is thus predominantly vertical; i.e. along the tank axis.

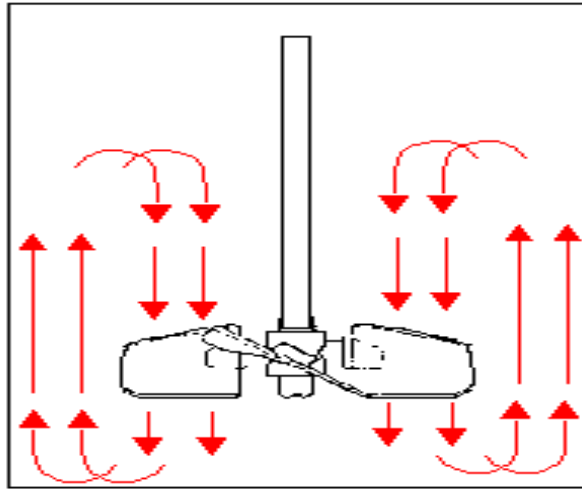

With axial impellers, the liquid is pushed in a downward direction; that is, along the axis of the reactor.

Fermenter Design

Low shear conditions are achieved by pitching the impeller blades at an angle and by making the edges of the impeller blades thin and smooth.



Fermenter Design

Intermig impeller is a axial flow impeller which is used for microbial fermentations. Following is the figure of axial flow impeller:

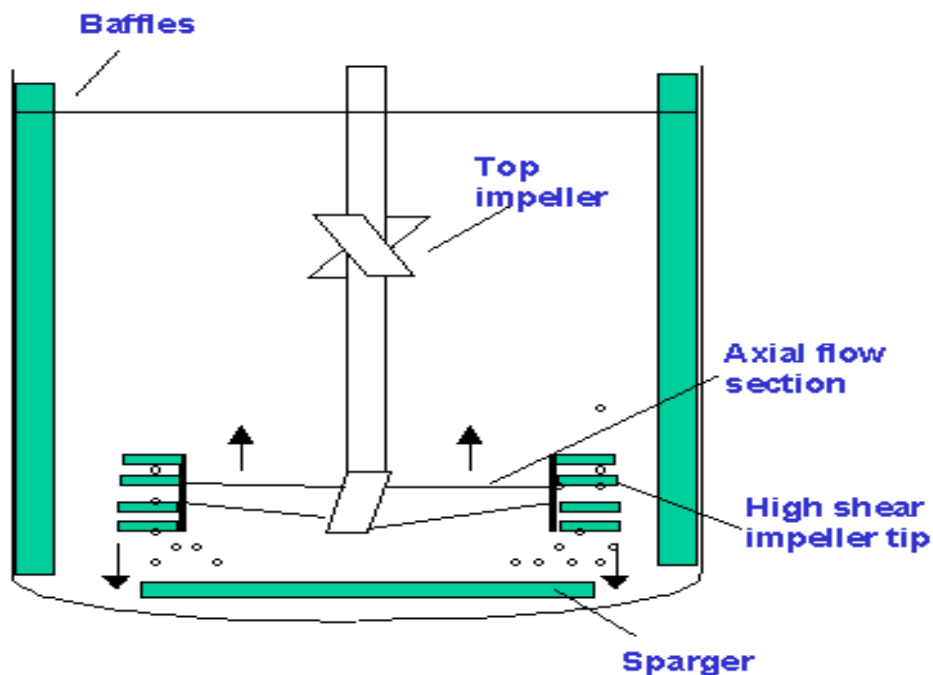

Fermenter Design

The agitation system has two impellers. The bottom impeller has a large axial flow section. The tips of the impeller contain finger like extensions which create a turbulent wake for breaking bubbles.

As the high shear region exists only at the tip, the overall shear conditions in the reactor are lower than would be generated by a radial flow impeller such as a Rushton Turbine.

Intermig impellers are used widely for agitation and aeration in fungal fermentations.

Fermenter Design

Disc Turbine

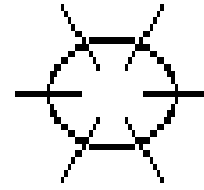
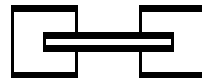

Vaned Disc

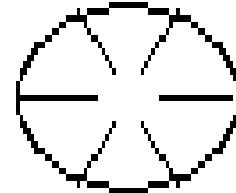

Open Turbine
(Variable Pitch)

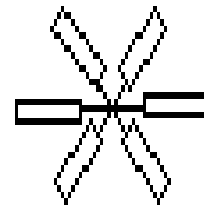
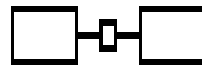

Fermenter Design



6 blade disk turbine



6 curved blade turbine

Fermenter Design



Screw Propeller



High efficiency hydrofoil propeller

END

Advances in Fermentation Technology

Lesson No.44

Fermenter Design: Temperature Control System-1

Fermenter Design

The temperature control system consists of

- i. **Temperature probes**
- ii. **Heat transfer system**

Fermenter Design

Typically the heat transfer system will use a "**jacket**" to transfer heat in or out of the reactor. The jacket is a shell which surrounds part of the reactor. The liquid in the jacket does not come in direct contact with the fermentation fluid.

Fermenter Design

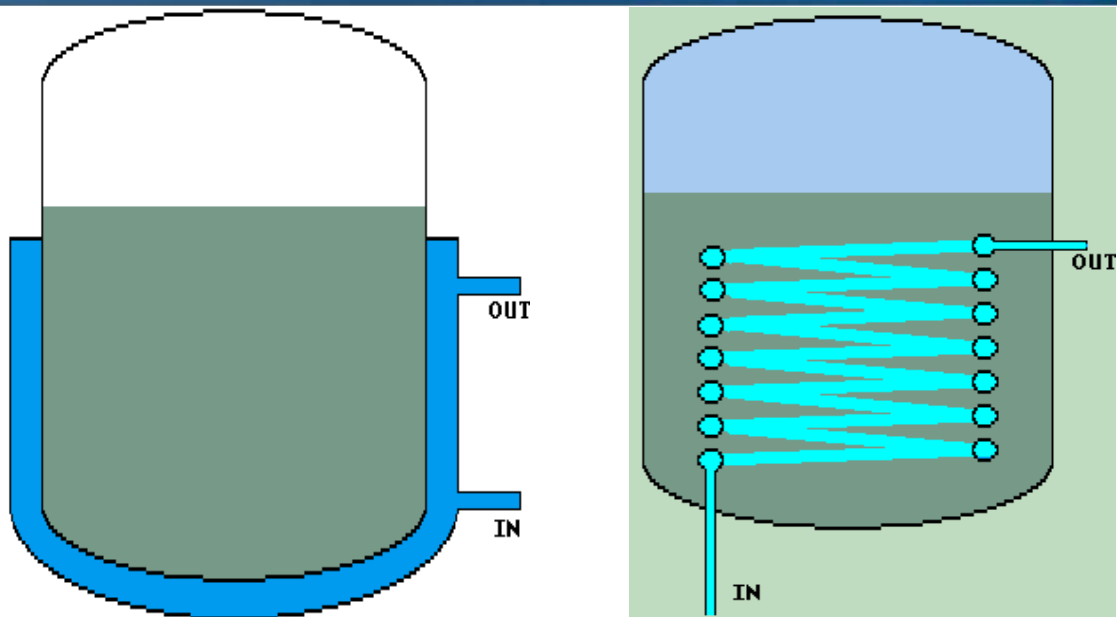

The jacket will typically be "dimpled" to encourage turbulence in the jacket and thus increase the heat transfer efficiency.

Fermenter Design

An alternative to using jackets are coils. Coils have a much higher heat transfer efficiency than jackets. However coils take up valuable reactor volume and can be difficult to clean and sterilize.

As probe; that is mostly pt100

END

Lesson No.45

Fermenter Design: Temperature Control System-2

Fermenter Design

The heating/cooling requirements are provided by the following methods:

	Laboratory-scale Reactors	Pilot and Production scale reactors
Heating Requirements	Electric Heaters	Steam generated in boilers
Cooling Requirements	Tap waters or refrigerated water baths	Cooling water produced by cooling towers or refrigerants such as ammonia

Fermenter Design

To make an accurate estimate of heating/cooling requirements for a specific process it is important to consider the **contributing factors**. An overall energy balance for a fermenter during normal operation can be written as:

$$Q_{\text{met}} + Q_{\text{ag}} + Q_{\text{gas}} = Q_{\text{acc}} + Q_{\text{exch}} + Q_{\text{evap}} + Q_{\text{sen}}$$

where Q_{met} = heat generation rate due to microbial metabolism,

Q_{ag} = heat generation rate due to mechanical agitation,

Q_{gas} = heat generation rate due to aeration power input,

Q_{acc} = heat accumulation rate by the system,

Q_{exch} = heat transfer rate to the surroundings and/or heat exchanger,

Q_{evap} = heat loss rate by evaporation,

Q_{sen} = rate of sensible enthalpy gain by the flow streams (exit – inlet).

Fermenter Design

Equation in the previous slide can be re-arranged as:

$$Q_{\text{exch}} = Q_{\text{met}} + Q_{\text{ag}} + Q_{\text{gas}} - Q_{\text{acc}} - Q_{\text{sen}} - Q_{\text{evap}}$$

Q_{exch} is the heat which will have to be removed by a cooling system.

The cooling requirements (jacket and/or pipes) to remove the excess heat from a fermenter may be determined by the following formula:

$$Q_{\text{exch}} = U \cdot A \cdot \Delta T$$

where A = the heat transfer surface available, m^2 ,

Q = the heat transferred, W,

U = the overall heat transfer coefficient, $\text{W}/\text{m}^2\text{K}$,

ΔT = the temperature difference between the heating or cooling agent and the mass itself, K.

Fermenter Design

It is impossible to specify accurately the necessary cooling surface of a fermenter since the temperature of the cooling water, the sterilization process, the cultivation temperature, the type of microorganism and the energy supplied by stirring can vary considerably in different process.

Fermenter Design

A cooling area of 50 to 70m² may be taken as average for 55,000L fermenter and with a coolant temperature of 14°C the fermenter may be cooled from 120 to 30°C in 2.5 to 4.0 hrs without stirring. The consumption of cooling water in this size of vessel during bacterial fermentation ranges from 500 to 2000 L/hr while fungi needs 2000 to 10,000 L/hr.

END

Lesson No.46

Fermenter Design: Oxygen Delivery System

Fermenter Design

The oxygen delivery system consists of: a **compressor**, an inlet air sterilization system, an **air sparger** exit air sterilization system.

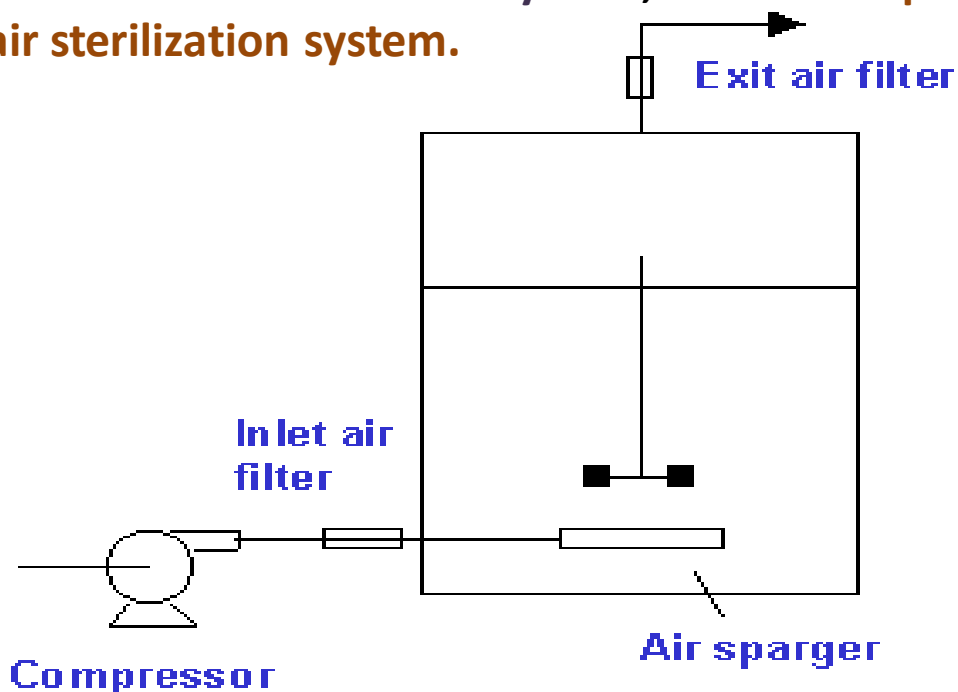

Fermenter Design

A compressor forces the air into the reactor. The compressor will need to generate sufficient pressure to force the air through the filter, sparger holes and into the liquid.

Air compressors used for large scale bioreactors typically produce air at **250 kPa**. The air should be dry and oil free so as to not block the inlet air filter or contaminate the medium.

Fermenter Design

It is very important that an "**instrument air**" compressor is not used. Instrument air is typically generated at higher pressures but is aspirated with oil. Instrument air compressors are used for pneumatic control.

END

Lesson No.47

Fermenter Design: Oxygen Delivery System- Air Sterilization System-1

Fermenter Design

Sterilization of the inlet air is undertaken to prevent contaminating organisms from entering the reactor.

The exit air on the other hand is sterilized not only to keep contaminants from entering but also to prevent organisms in the reactor from contaminating the air.

A common method of sterilizing the inlet and exit air is filtration. For small reactors (with volumes less than 5 litres), disk shaped hydrophobic Teflon membranes housed in a polypropylene housing are used. Teflon is tough, reusable and does not readily block.

Fermenter Design

For larger laboratory scale fermenters (up to 1000 litres), pleated membrane filters housed in polypropylene cartridges are used.

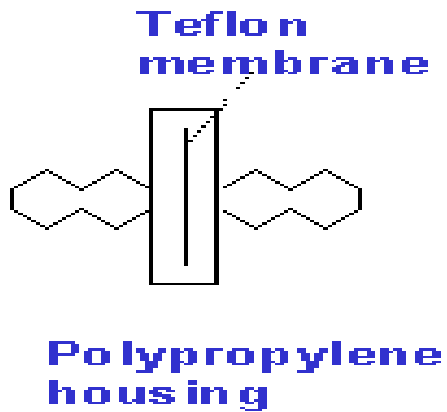

Fermenter Design

By pleating the membrane, it is possible to create a compact filter with a very large surface area for air filtration. Increasing the filtration area decreases the pressure required to pass a given volume of air through the filter.

END

Lesson No.48

Fermenter Design: Oxygen Delivery System- Air Sterilization System-2

Fermenter Design

- Sterilization of the inlet and exit air in large bioreactors (>10,000 liters) can present a major design problem. Large scale membrane filtration is a very expensive process. The filters are expensive as they are difficult to make and the energy required to pass air through a filter can be quite considerable.
- Heat sterilization is alternative option. Steam can be used to sterilize the air. With older style compressors, it was possible to use the heat generated by the air compression process to sterilize the air. However, compressors are now multi-stage devices which are cooled at each stage and disinfecting temperatures are never reached.

Fermenter Design

In small reactors, the exit air system will typically include a condenser.

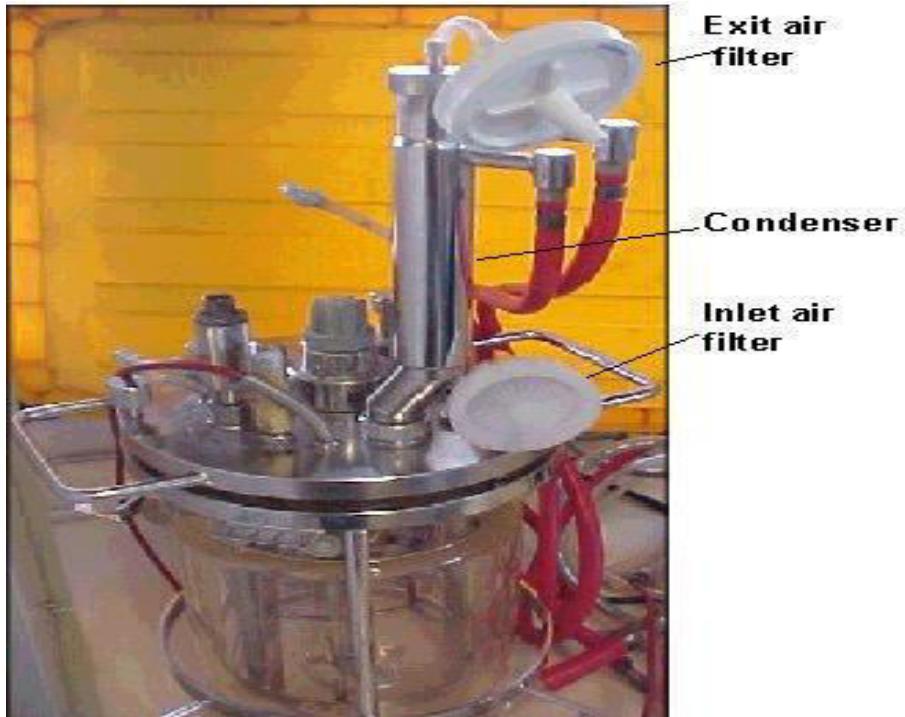

Fermenter Design

High-efficiency particulate arrestance (HEPA) Filter

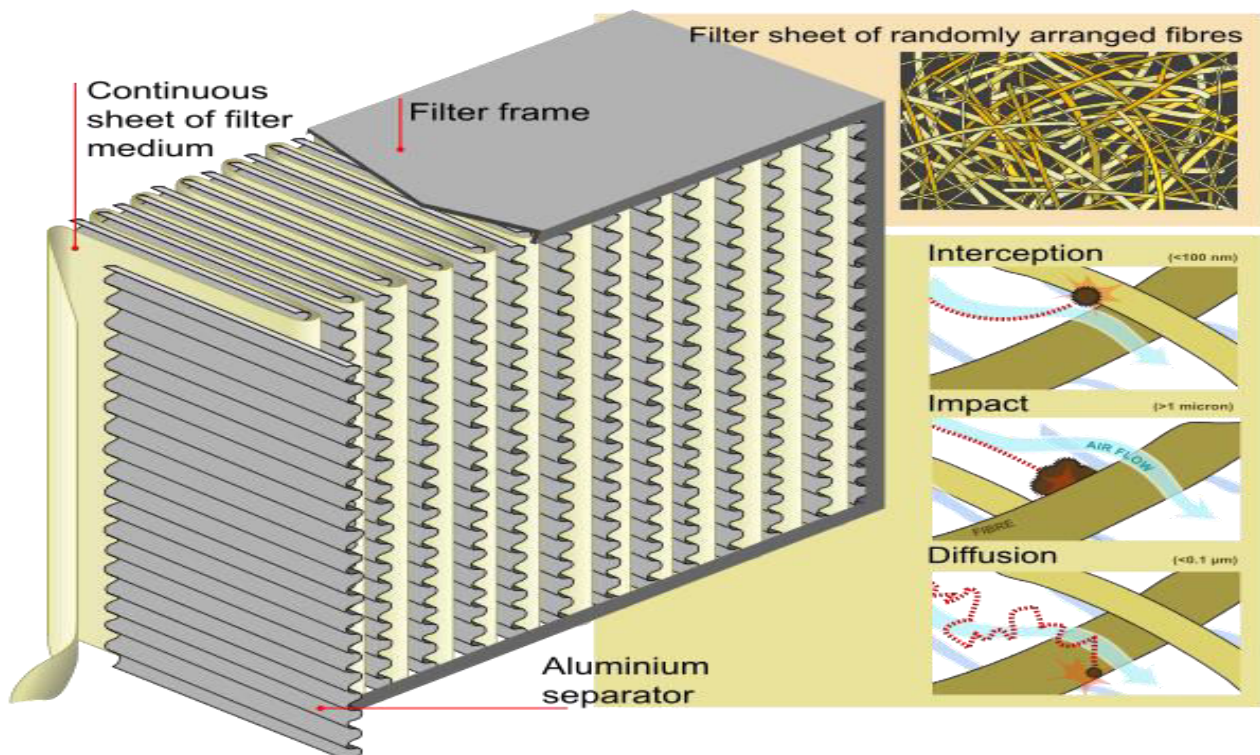

Fermenter Design



Fermenter Design

- **The condenser is a simple heat exchanger through which cool water is passed.**
- **Volatile materials and water vapour condense on the inner condenser surface.**
- **This minimizes water evaporation and the loss of volatiles.**
- **Drying the air also prevents blocking of the exit air filter with water.**

END

Lesson No.49

Fermenter Design: Oxygen Delivery System- Air Sterilization System-3

Fermenter Design

- ✓ During sterilization the concept of "maintaining positive pressure" is often used.
- ✓ Maintaining positive pressure means that during sterilization, cooling and filling and if appropriate, the fermentation process, air must be pumped into the reactor.
- ✓ In this way the reactor is always pressurized and thus aerial contaminants will not be "sucked" into the reactor.
- ✓ It is very important that positive pressure is maintained when the bioreactor is cooled following sterilization. Without air being continuously pumped into the reactor, a vacuum will form and contaminants will tend to be drawn into the reactor.

Fermenter Design

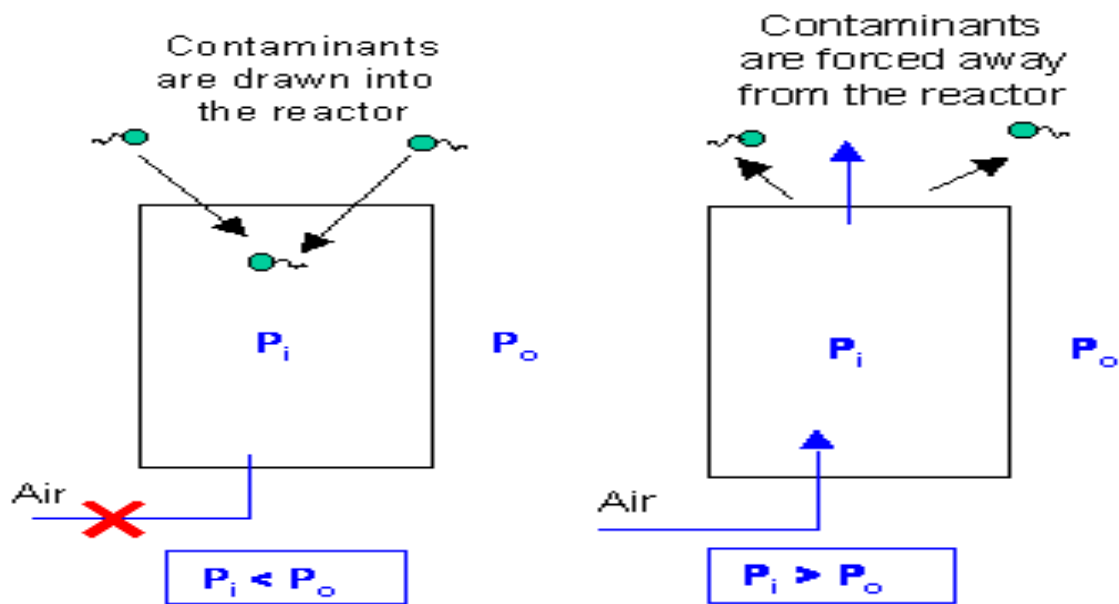

Without aeration, a vacuum forms as the reactor cools.

With aeration, positive pressure is always maintained and contaminants are pushed away from the reactor

Fermenter Design

Maintaining positive pressure at all stages of the fermentation setup and operation is an important aspect of reducing the risk of contamination.

END

Lesson No.50

Fermenter Design: Oxygen Delivery System - Sparger

Fermenter Design

The air sparger is used to break the incoming air into small bubbles.

Although various designs can be used such as porous materials made of glass or metal, the most common type of filter used in modern bioreactors is the sparge ring:

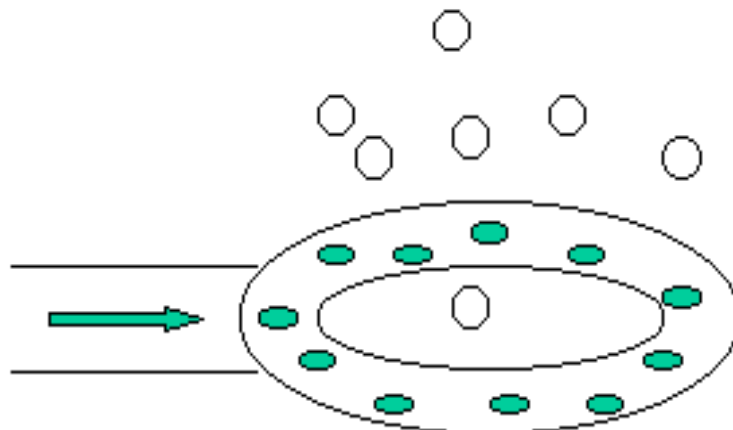

Fermenter Design

A sparger ring consists of a hollow tube in which small holes have been drilled. A sparger ring is easier to clean than porous materials and is less likely to block during a fermentation.

During the emptying of a fermenter, it is important that the air feed valve is closed. This will minimize the contamination of the inlet air line

Bubbles rise directly beneath the impeller. Shear forces are highest around the impeller. This maximizes efficiency of bubble break-up.

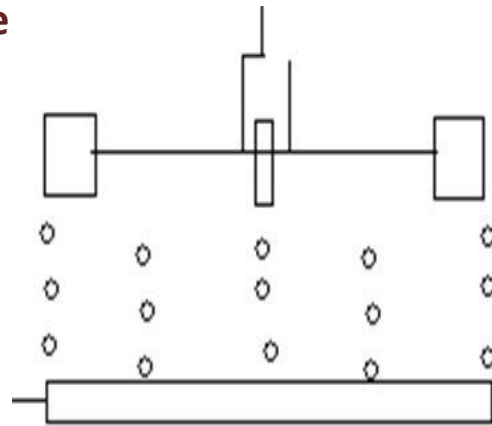

Fermenter Design

➤ The sparger ring must be located below the agitator and will have approximately the same diameter as the impeller.

➤ Thus, the bubbles rise directly into the impeller blades, facilitating bubble break up.

Fermenter Design

The shear forces that an impeller generates play a major role in determining bubble size. If the impeller speed is too slow then the bubbles will not be broken down. In addition, if the impeller speed is too slow, then the bubbles will tend to rise directly to the surface due to their buoyancy

Fermenter Design

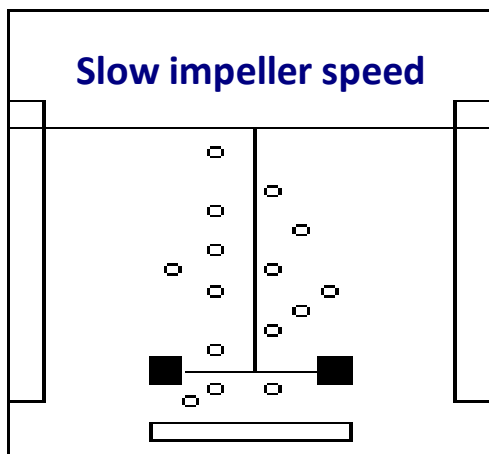

The bubbles will not be sheared into smaller bubbles and will tend to rise directly towards the surface

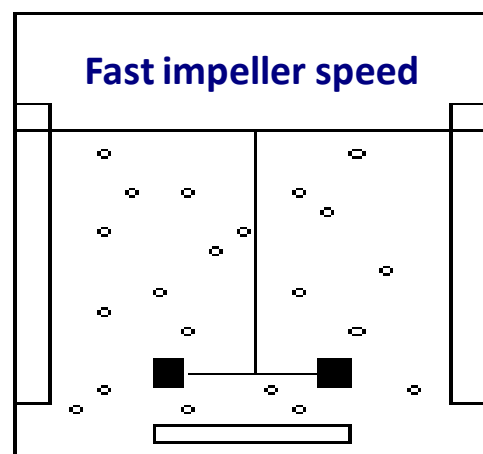

Smaller bubbles will be generated and these bubbles will move with throughout the reactor increasing the gas hold up and bubble residence time

Fermenter Design

- Another consequence of too slow impeller speed is a flooded impeller.
- Under these conditions, the bubbles will accumulate and coalesce under the impeller, leading to the formation of large bubbles and poor oxygen transfer rates.
- A similar phenomenon will happen when aeration rate is too high. In this case, the oxygen transfer efficiency will be low.

FND

www.vaCTn.com

BIO204 Complete MERGED

PPT Slides 1 TO 91

Regards : Zarva Chaudhary

Merged File date 2021

Admin:

* Zarva Chaudhary *

Chaudhary Moazzam

*** Laiba Maki ***

Lesson No.51

Fermenter Design: Oxygen Delivery System- Air Flow Rate

Fermenter Design

Air flow rates are typically reported in terms of volume per volume per minute or *vvm*, which is defined as:

$$vvm = \frac{\text{Volumetric air flow rate}}{\text{Liquid volume}}$$

Note the unit convention, The air flow rate and liquid volume must have the same basal unit. The air flow rate must be expressed in terms of volume per minute (L/L/m).

Fermenter Design

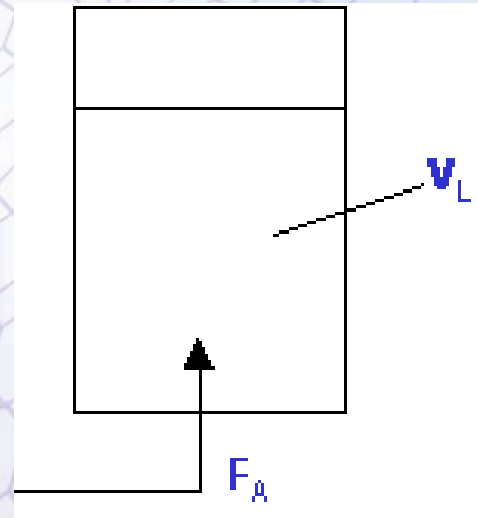

END

Advances in Fermentation Technology

Lesson No.52

Fermenter Design: Foam Control System-1

Fermenter Design

Foam control is an essential element of the operation of a sparged bioreactor. The following photograph shows the accumulation of foam in a **2 liter** laboratory reactor.



Fermenter Design

- Excessive foam formation can lead to blocked air exit filters and to pressure build up in the reactor.
- The latter can lead to a loss of medium, damage to the reactor and even injury to operating personnel.

Fermenter Design

- **Foam is typically controlled with aid of antifoaming agents based on silicone or on vegetable oils.**

- **Excessive antifoam addition can however result in poor oxygen transfer rates.**

END

Advances in Fermentation Technology

Lesson No.53

**Fermenter
Design:
Foam Control
System-2**

Fermenter Design

- **Antifoam requirement will depend on:**
 - i. The nature of the medium: Media rich in proteins will tend to foam more readily than simple media.
 - ii. **The products produced by the fermentation: Secreted proteins or nucleic acids released as a result of cell death and hydrolysis have detergent like properties.**
 - iii. **The aeration rate and stirrer speed: Increasing the aeration rate and stirrer speed increases foaming problems.**
 - iv. **The use of mechanical foam control devices: Foam control devices such as mechanical and ultrasonic foam breakers help to reduce the antifoam requirement.**

Fermenter Design

- **Antifoam requirement will depend on:**
 - v. **The head space volume: The larger headspace volume, then the greater the tendency for the foam to collapse under its own weight. For example, for fermentations in which high levels of foam is produced, a 50% headspace volume may be required.**
 - vi. **Condenser temperature: In laboratory scale reactors, a cold condenser temperature can help to control the foam. The density of the foam increases when it moves from the warm headspace volume to the cold condenser region. This causes the foam to collapse.**

Fermenter Design

➤ Foam Cutters

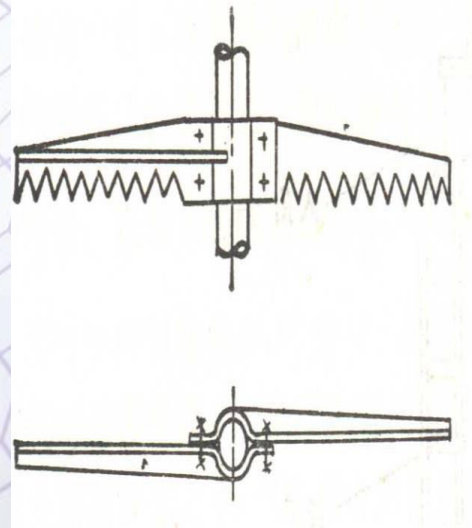

Fermenter Design

➤ Foam Cutters

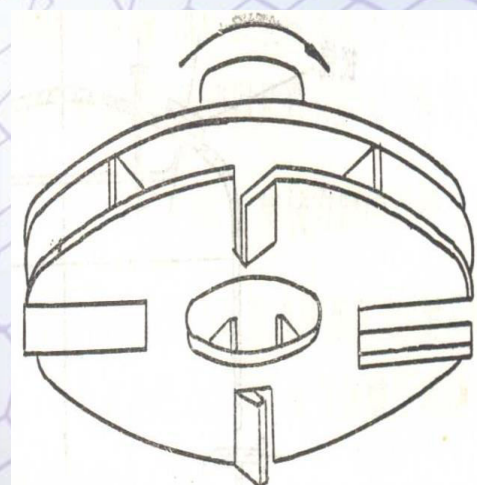

Fermenter Design

➤ **Foam Cutters**

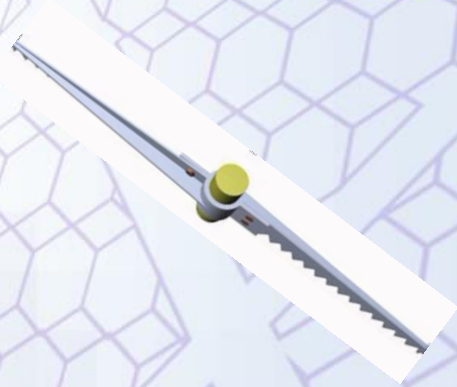

END

Advances in Fermentation Technology

Lesson No.54

**Fermenter
Design:
Foam Control
System-3**

Fermenter Design

Foam is typically detected using two conductivity or "level" probes.

One probe is immersed in the fermentation liquid while the other placed above the liquid level.

When the foam reaches the upper probe, a current is carried through the foam. The detection of a current by the foam controller results in the activation of a pump and the antifoam is then added until the foam subsides.

Fermenter Design

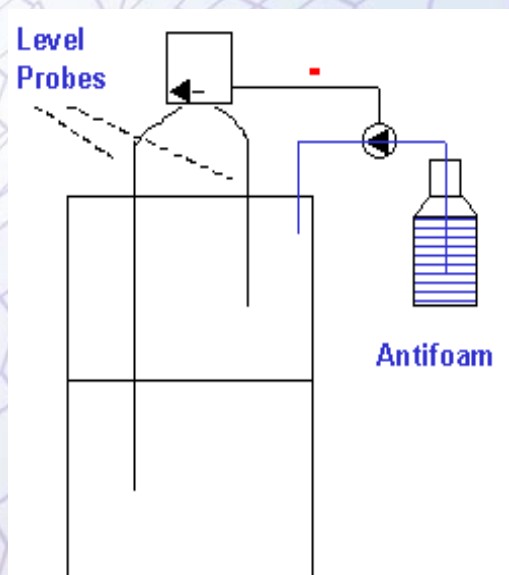

Fermenter Design

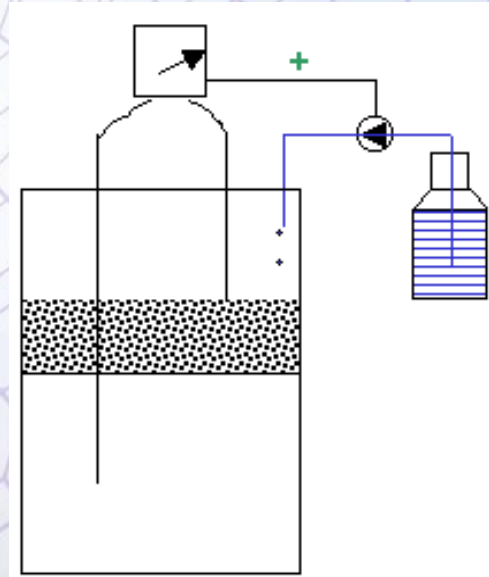

END

Advances in Fermentation Technology

Lesson No.55

**Fermenter
Design:
pH Control
System-1**

Fermenter Design

☐ Neutralizing Agents:

The neutralizing agents used to control pH should be non-corrosive. They should also be non-toxic to cells when diluted in the medium.

- Potassium hydroxide is preferred to **NaOH**, as potassium ions tend to be less toxic to cells than sodium ions. However **KOH** is more expensive than NaOH. Sodium carbonate is also commonly used in small scale bioreactor systems.
- **Hydrochloric acid** should never be used as it is corrosive even to stainless steel.
- **Likewise, sulphuric acid concentrations should not be between 10% and 80% as between this range, sulphuric acid is most corrosive.**

Fermenter Design

☐ Neutralizing Agents:

- For laboratory fermenters, a peristaltic pump is used to add the pH adjusting agents. **Silicone tubing** is often used. However, note that silicone tubing will decay in the presence of high alkali concentrations. Thick walled silicone tubing should be used.
- Alternatively **Tygon or Neoprene** tubing can be used. Tygon is not autoclavable but can be sterilized by passing the NaOH through the tubing for about 1 hour. Neoprene is autoclavable but is not transparent or translucent as is Tygon or silicone.

Fermenter Design

For fermentations that produce large amounts of acids, for example lactic acids fermentation using media containing high sugar concentrations, high concentrations of alkali (**4 M and above**) are preferred. This will prevent dilution of the medium due to the addition of excessive addition of the alkali solution.

END

Advances in Fermentation Technology

Lesson No.56

**Fermenter
Design:
pH Control
System-2**

Fermenter Design

The pH control system consists of: a **pH probe**, alkali delivery system & **acid delivery system**. The pH probe is typically steam sterilizable.

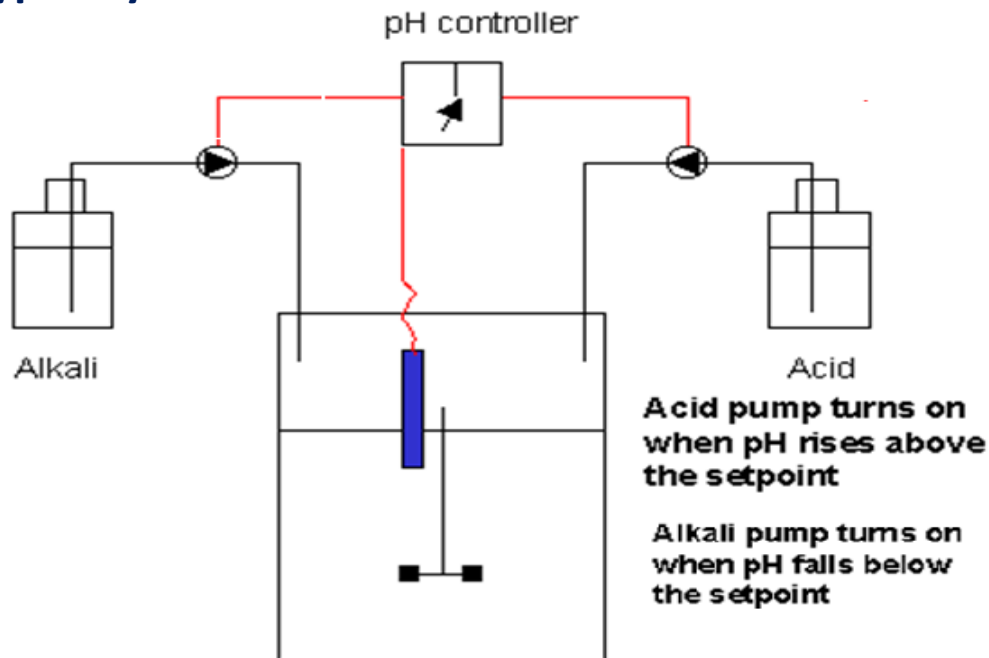

Fermenter Design

The pH control system (and indeed all other fermenter control systems) are designed to have a **dead-band**. A dead-band is used to prevent excessive alkali and acid addition. The pH control dead-band is shown in following diagram:

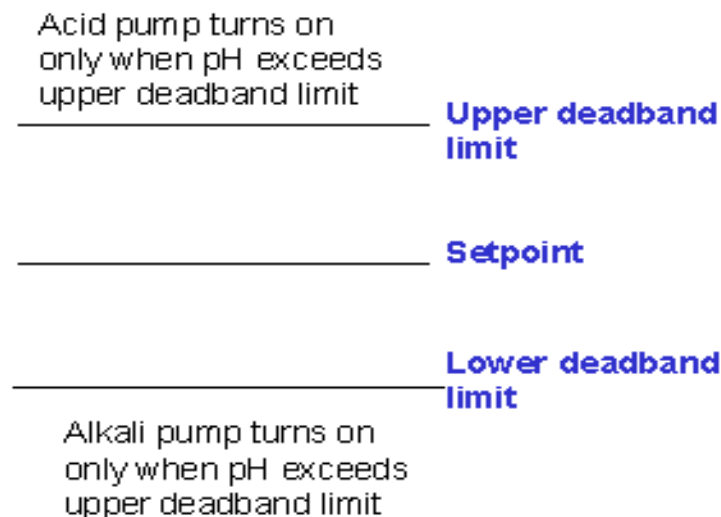

Fermenter Design

The set-point is the pH at which the fermenter is being attempted to be controlled at. For example, if the fermentation is to be run at a constant pH of 6.5, then the set-point is set to 6.50.

If for example, a 5% dead-band is used, then the upper dead-band limit will be

$$1.05 \times 6.5 = 6.83$$

and the lower dead-band limit will be

$$0.95 \times 6.5 = 6.18$$

If the dead-band is too small, then it is possible that pH will often overshoot and undershoot the dead-bands leading to excessive alkali and acid addition. The trade off is that a wide dead-band will lead to less precise pH control.

Fermenter Design

As many fermentations tend to produce acids rather than substances that increase the pH, acid addition is often not required. Indeed not all fermentations need continuous pH control.

END

Lesson No.57

Fermenter Design: Cleaning, Sterilization & Sampling Facilities

Fermenter Design

❑ Cleaning & Sterilization Facilities:

Small scale reactors are taken apart and then cleaned before being re-assembled, filled and then sterilized in an autoclave.

However, reactors with volumes greater than 5 liters cannot be placed in an autoclave and sterilized. These reactors must be cleaned and sterilized "in place". This process is referred to "**Clean in Place**".

CIP involves the complete cleaning of not only the fermenter but also all lines linked to the internal components of the reactor. Steam, cleaning and sterilizing chemicals, spray balls and high pressure pumps are used in these processes. The process is usually automated to minimize the possibility of human error.

Fermenter Design

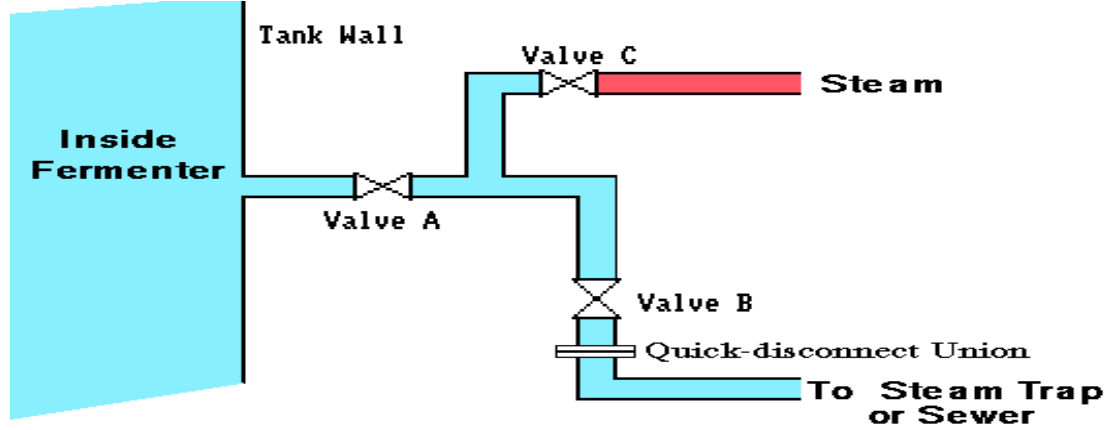
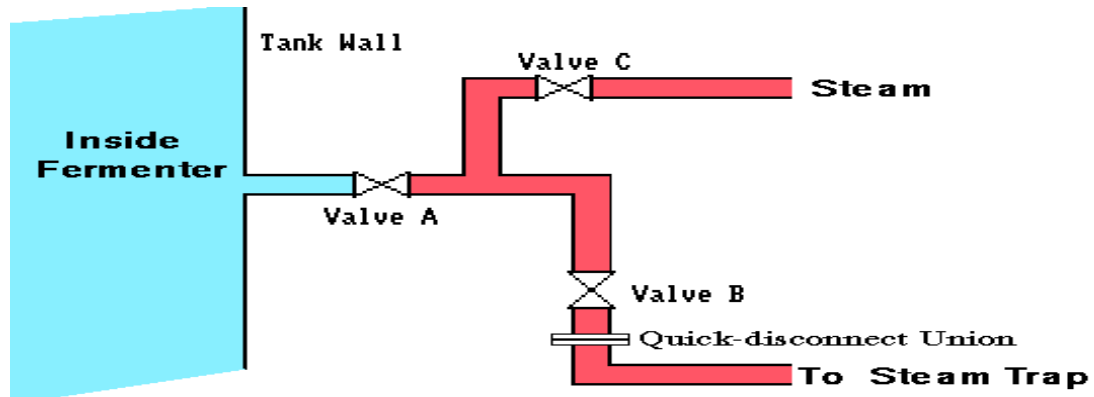

Fermenter Design

☐ Sampling:

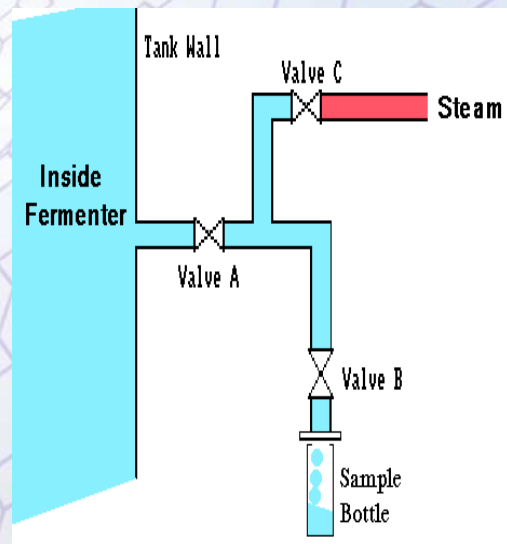

END

Lesson No.58

Sterilization: Introduction-1

Sterilization

A FERMENTATION product is produced by the culture of a certain organism, or organisms, in a nutrient medium. If the fermentation is invaded by a foreign microorganism then the following consequences may occur:

Sterilization

- i. The medium would have to support the growth of both the production organism and the contaminant, resulting in a loss of productivity.**
- ii. If the fermentation is a continuous one then the contaminant may 'outgrow' the production organism and displace it from the fermentation.**
- iii. The foreign organism may contaminate the final product, e.g. single-cell protein where the cells, separated from the broth, constitute the product.**
- iv. The contaminant may produce compounds which make subsequent extraction of the final product difficult.**

Sterilization

- v. The contaminant may degrade the desired product; this is common in bacterial contamination of antibiotic fermentations where the contaminant would have to be resistant to the normal inhibitory effects of the antibiotic and degradation of the antibiotic is a common resistance mechanism, e.g. the degradation of β -lactam antibiotics by β -lactamase producing bacteria.**
- vi. Contamination of a bacterial fermentation with phage could result in the lysis of the culture.**

Sterilization

Sterilization is the removal or destruction of all living microorganisms. Heating is the most common method used for killing microbes, including the most resistant forms, such as endospores. A sterilizing agent is called a **sterilant**. Liquids or gases can be sterilized by filtration.

END

Advances in Fermentation Technology

Lesson No.59

Sterilization:
Introduction-2

Sterilization

Avoidance of contamination may be achieved by:

- i. Using a pure inoculum to start the fermentation.
- ii. Sterilizing the medium to be employed.
- iii. Sterilizing the fermenter vessel.
- iv. Sterilizing all materials to be added to the fermentation during the process.
- v. Maintaining aseptic conditions during the fermentation.

Sterilization

The extent to which these procedures are adopted is determined by the likely probability of contamination and the nature of its consequences. Some fermentations are described as 'protected' - that is, the medium may be utilized by only a very limited range of microorganisms, or the growth of the process organism may result in the development of selective growth conditions, such as a reduction in pH. The brewing of beer falls into this category; hop resins tend to inhibit the growth of many micro-organisms and the growth of brewing yeasts tends to decrease the pH of the medium.

Sterilization

Thus, brewing worts are boiled, but not necessarily sterilized, and the fermenters are thoroughly cleaned with disinfectant solution but are not necessarily sterile.

Also, the precautions used in the development of inoculum for brewing are far less stringent than, for example, in an antibiotic fermentation.

Sterilization

However, the vast majority of fermentations are not 'protected' and, if contaminated, would suffer some of the consequences previously listed.

END

Lesson No.60

MEDIUM Sterilization-1

Sterilization

Media may be sterilized by filtration, radiation, ultrasonic treatment, chemical treatment or heat. However, for practical reasons, steam is used almost universally for the sterilization of fermentation media. The major exception is the use of filtration for the sterilization of media for animal-cell culture - such media are completely soluble and contain heat labile components making filtration the method of choice. Filtration techniques will be considered in later modules.

Before the techniques which are used for the steam sterilization of culture media are discussed it is necessary to discuss the kinetics of sterilization.

Sterilization

The destruction of microorganisms by steam (moist heat) may be described as a first-order chemical reaction and, thus, may be represented by the following equation:

$$-dN/dt = kN$$

where N is the number of viable organisms present,
 t is the time of the sterilization treatment,
 k is the reaction rate constant of the reaction,
or the specific death rate.

It is important at this stage to appreciate that we are considering the total number of organisms present in the volume of medium to be sterilized, not the concentration - **the minimum number of organisms to contaminate a batch is one, regardless of the volume of the batch.**

Sterilization

On integration of equation (in previous slide) the following expression is obtained:

$$\ln (N_t/N_0) = -kt$$

The graphical representations of above two equations are illustrated in Figure (in next slide), from which it may be seen that viable organism number declines exponentially over the treatment period. A plot of the natural logarithm of N_t/N_0 against time yields a straight line, the slope of which equals $-k$.

Sterilization

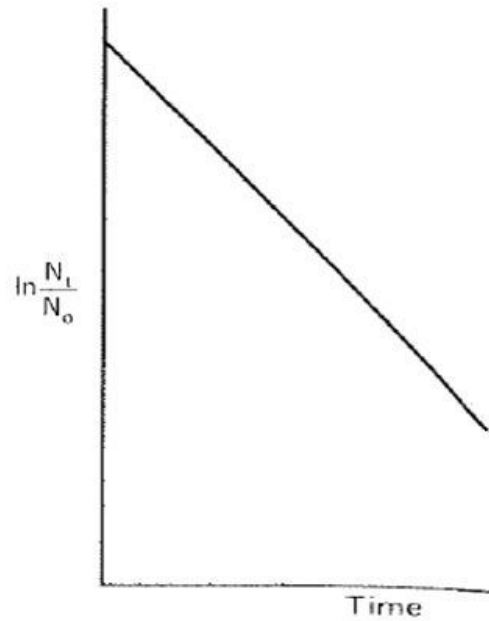
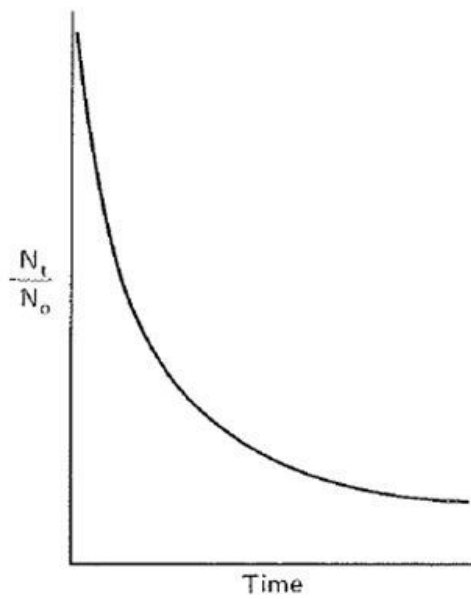

Plots of the proportion of survivors and the natural logarithm of the proportion of survivors in a population of microorganisms subjected to a lethal temperature over a time period.

Sterilization

This kinetic description makes two predictions which appear anomalous:

- i. An infinite time is required to achieve sterile conditions (i.e. $N_t = 0$).
- i. After a certain time there will be less than one viable cell present.

END

Lesson No.61

MEDIUM Sterilization-2

Sterilization

As per context of the discussion in previous module, a value of N_t of less than one is considered in terms of the probability of an organism surviving the treatment. For example, if it were predicted that a particular treatment period reduced the population to 0.1 of a viable organism, this implies that the probability of one organism surviving the treatment is one in ten. This may be better expressed in practical terms as a risk of one batch in ten becoming contaminated.

The value of k is not only species dependent, but dependent on the physiological form of the cell; for example, the endospores of the genus *Bacillus* are far more heat resistant than the vegetative cells.

Sterilization

Figures in next slides illustrate the effect of the time of heat treatment on the survival of a population of bacterial endospores.

Sterilization

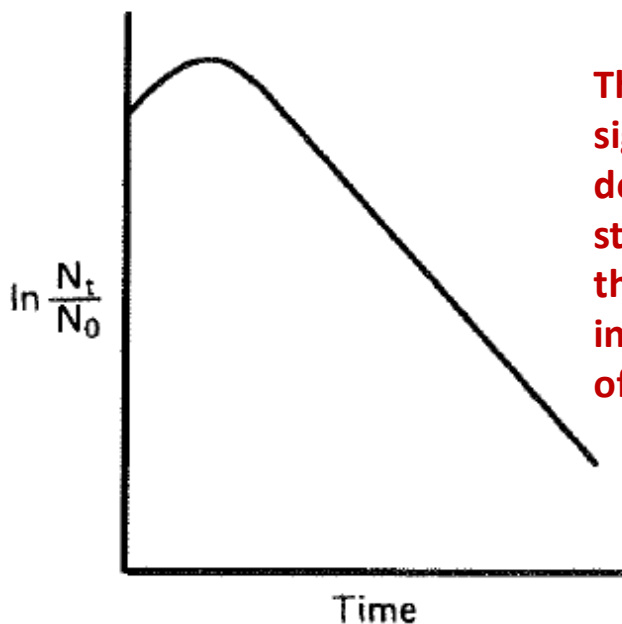

The activation of spores is significantly more than their destruction during the early stages of the process and, therefore, viable numbers increase before the observation of exponential decline.

Initial population increase resulting from the heat activation of spores in the early stages of a sterilization process

Sterilization

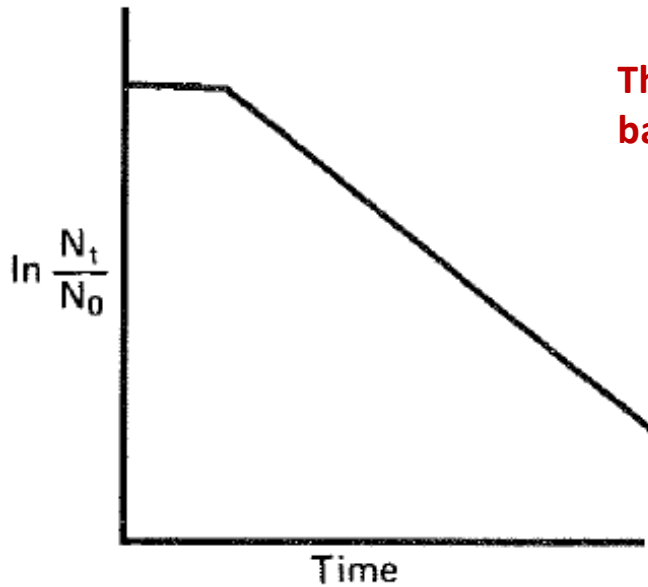

The activation of spores is balanced by spore death.

An initial stationary period observed during a sterilization treatment due to the death of spores being completely compensated by the heat activation of spores

Sterilization

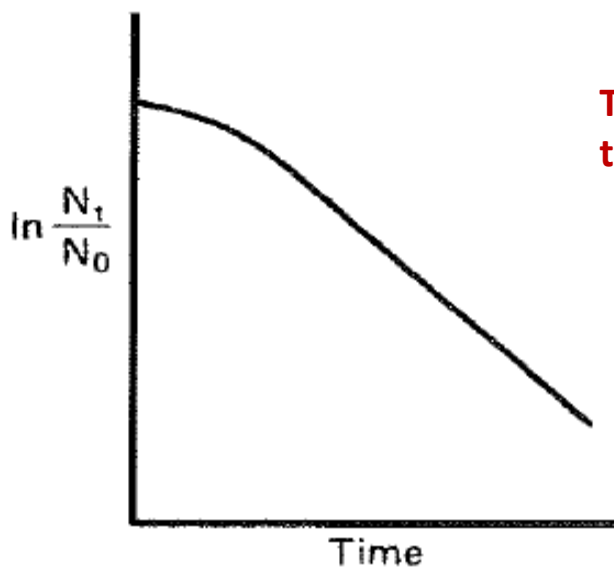

The activation of spores is less than spore death.

Initial population decline at a sub-maximum rate during a sterilization treatment due to the death of spores being compensated by the heat activation of spores

Sterilization

The deviation from an immediate exponential decline in viable spore number is due to the heat activation of the spores, that is the induction of spore germination by the heat and moisture of the initial period of the sterilization process.

END

Advances in Fermentation Technology

Lesson No.62

MEDIUM
Sterilization-3

Sterilization

Figures in next slides illustrate typical results of the sterilization of mixed cultures containing two species with different heat sensitivities.

Sterilization

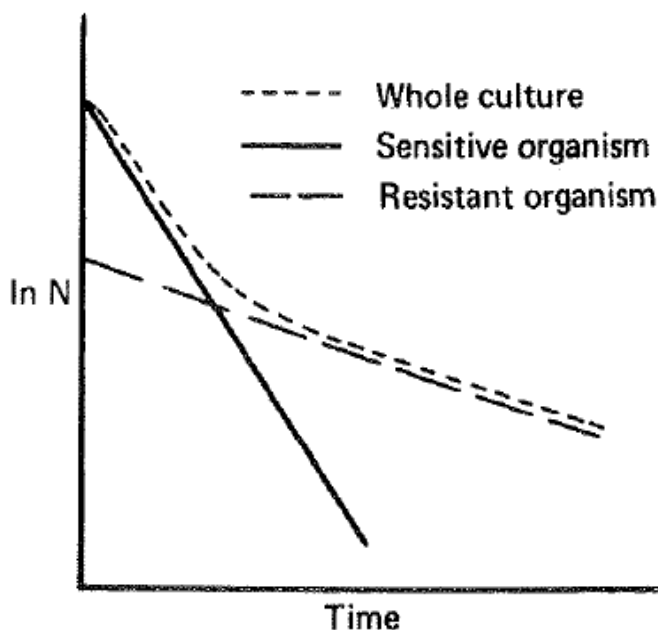

The effect of a sterilization treatment on a mixed culture consisting of a high proportion of a very sensitive organism

In this case, the population consists mainly of the less-resistant type where the initial decline is due principally to the destruction of the less-resistant cell population and the later, less rapid decline, is due principally to the destruction of the more resistant cell population.

Sterilization

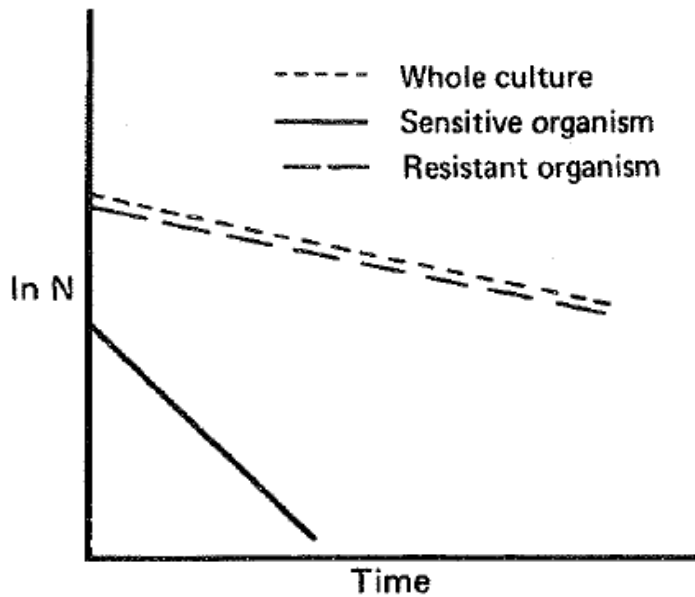

This case represents the reverse situation where the more resistant type predominates and its presence disguises the decrease in the number of the less resistant type.

The effect of a sterilization treatment on a mixed culture consisting of a high proportion of a relatively resistant organism

Sterilization

As with any first-order reaction, the reaction rate increases with increase in temperature due to an increase in the reaction rate constant, which, in the case of the destruction of micro-organisms, is the specific death rate (k). Thus, k is a true constant only under constant temperature conditions.

Sterilization

The relationship between temperature and the reaction rate constant was demonstrated by Arrhenius and may be represented by the equation:

$$d \ln k / dT = E / RT^2$$

where E is the activation energy,
 R is the gas constant,
 T is the absolute temperature.

On integration, above equation gives:

$$k = Ae^{-E/RT}$$

where A is the Arrhenius constant.

On taking natural logarithms, this equation becomes:

$$\ln k = \ln A - E/RT$$

Sterilization

From the last equation it may be seen that a plot of $\ln k$ against the reciprocal of the absolute temperature will give a straight line. Such a plot is termed an Arrhenius plot and enables the calculation of the activation energy and the prediction of the reaction rate for any temperature.

END

Lesson No.63

MEDIUM Sterilization-4

Sterilization

By combining together equations $\ln (N_t/N_0) = -kt$ and $k = Ae^{-E/RT}$, the following expression may be derived for the heat sterilization of a pure culture at a constant temperature:

$$\ln N_0/N_t = A \cdot t \cdot e^{-E/RT}$$

Deindoerfer and Humphrey (1959) used the term $\ln N_0/N_t$ as a design criterion for sterilization, which has been variously called the **Del factor**, Nabla factor and sterilization criterion represented by the term ∇ . Thus, the Del factor is a measure of the fractional reduction in viable organism count produced by a certain heat and time regime. Therefore:

$$\nabla = \ln (N_0/N_t)$$

Sterilization

but $\ln(N_0/N_t) = kt$

and $kt = A \cdot t \cdot e^{-(E/RT)}$

thus $\nabla = A \cdot t \cdot e^{-(E/RT)}$.

On rearranging, above equation becomes:

$$\ln t = E/RT + \ln (\nabla/A)$$

Thus, a plot of the natural logarithm of the time required to achieve a certain ∇ value against the reciprocal of the absolute temperature will yield a straight line, the slope of which is dependent on the activation energy, as shown in Fig. on next slide.

Sterilization

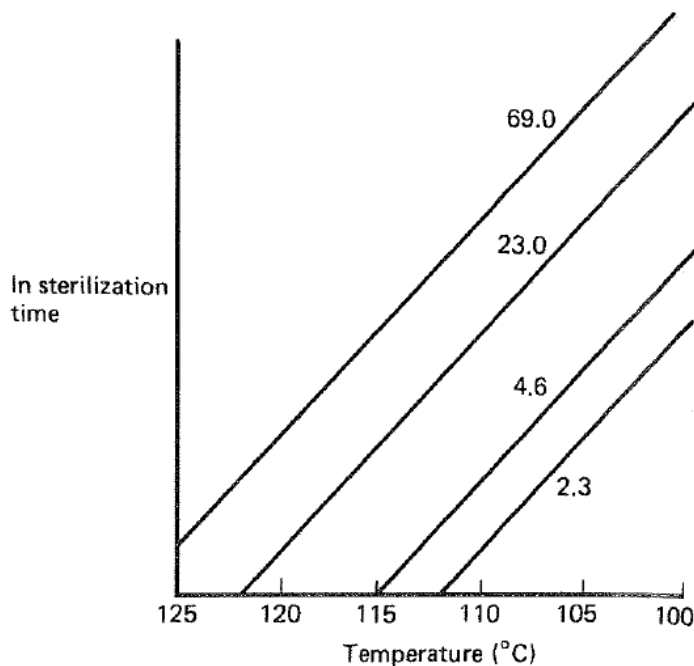

From Fig. it is clear that the same degree of sterilization (∇) may be obtained over a wide range of time and temperature regimes; that is, the same degree of sterilization may result from treatment at a high temperature for a short time as from a low temperature for a long time.

The effect of sterilization and temperature on the Del factor achieved in the process. The figures on the graph indicate the Del factors for each straight line.

Sterilization

END

This kinetic description of bacterial death enables the design of procedures (giving certain ∇ factors) for the sterilization of fermentation broths. By choosing a value for N_t , procedures may be designed having a certain probability of achieving sterility, based upon the degree of risk that is considered acceptable.

Advances in Fermentation Technology

Lesson No.64

MEDIUM
Sterilization-5

Sterilization

A fermentation medium is not an inert mixture of components and deleterious reactions may occur in the medium during the sterilization process, resulting in a loss of nutritive quality. Thus, the choice of regime is dictated by the requirement to achieve the desired reduction in microbial content with the least detrimental effect on the medium.

Figure in net slide, illustrates the deleterious effect of increasing medium sterilization time on the yield of product of subsequent fermentations. **The initial rise in yield is due to some components of the medium being made more available to the process micro-organism by the 'cooking effect' of a brief sterilization period.**

Sterilization

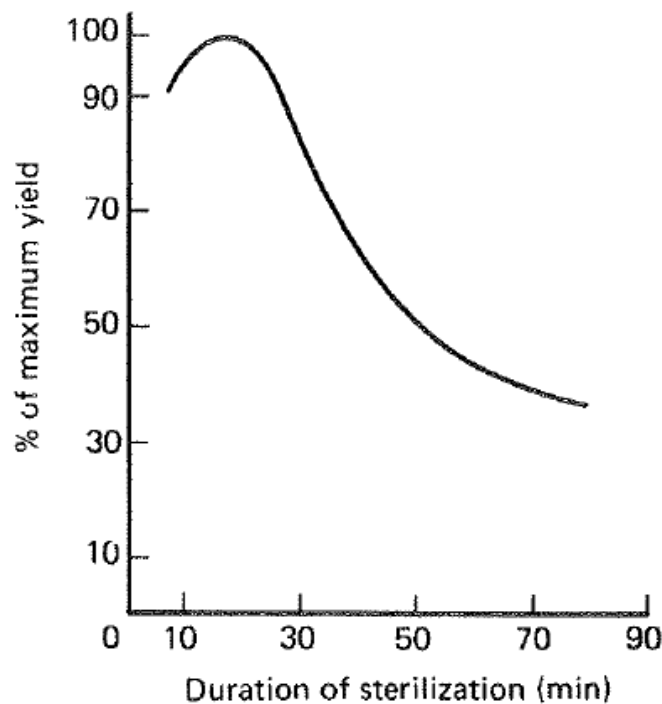

The effect of the time of sterilization on the yield of a subsequent fermentation

Sterilization

Two types of reaction contribute to the loss of nutrient quality during sterilization:

i. Interactions between nutrient components of the medium.

A common occurrence during sterilization is the **Maillard-type browning reaction** which results in discoloration of the medium as well as loss of nutrient quality. These reactions are normally caused by the reaction of carbonyl groups, usually from reducing sugars, with the amino groups of amino acids and proteins. An example of the effect of sterilization time on the availability of glucose in a corn-steep liquor medium is shown in Table (in next slide). Problems of this type are normally resolved by sterilizing the sugar separately from the rest of the medium and recombining the two after cooling.

Sterilization

The effect of sterilization time on glucose concentration and product accretion rate in an antibiotic fermentation

Time at 121° (min)	Amount of added glucose remaining (%)	Relative accretion rate
60	35	90
40	46	92
30	64	100

Sterilization

ii. Degradation of heat labile components.

Certain vitamins, amino acids and proteins may be degraded during a steam sterilization regime. In extreme cases, such as the preparation of media for animal-cell culture, **filtration may be used.**

END

Advances in Fermentation Technology

Lesson No.65

MEDIUM
Sterilization-6

Sterilization

The thermal destruction of essential media components conforms approximately with first order reaction kinetics and, therefore, may be described by equations similar to those derived for the destruction of bacteria:

$$x_t/x_0 = e^{-kt}$$

where x_t is the concentration of nutrient after a heat treatment period, t ,

x_0 is the original concentration of nutrient at the onset of sterilization,

k is the reaction rate constant.

The effect of temperature on the reaction rate constant may be expressed by the Arrhenius equation:

$$\ln k = \ln A - E / RT$$

Sterilization

Therefore, a plot of the natural logarithm of the reaction rate against $1/T$ will give a straight line, slope $-(E/R)$. As the value of R , the gas constant, is fixed the slope of the graph is determined by the value of the activation energy (E). The activation energy for the thermal destruction of *B. stearothermophilus* spores has been cited as 67.7 kcal mole⁻¹, whereas that for thermal destruction of nutrients is 10 to 30 kcal mole⁻¹.

Figure (in next slide) is an Arrhenius plot for two reactions - one with a lower activation energy than the other.

Sterilization

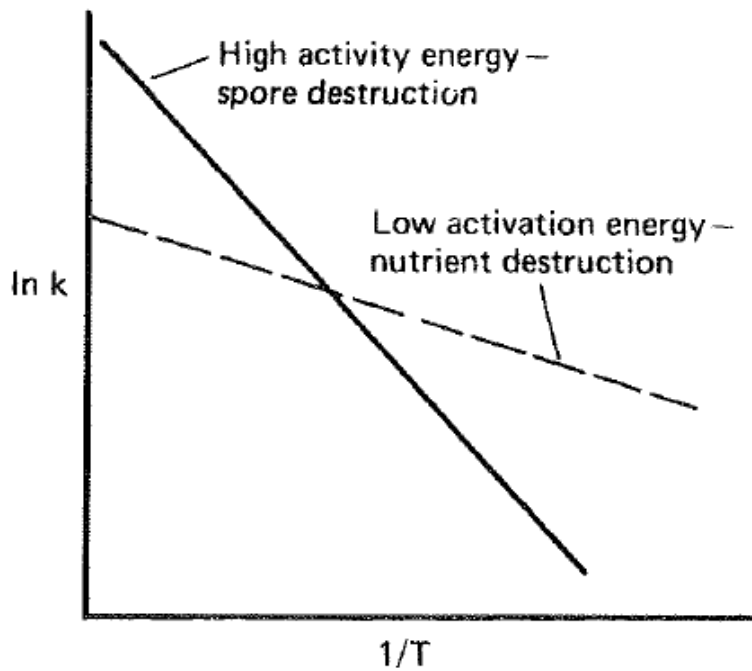

From this plot it may be seen that as temperature is increased, the reaction rate rises more rapidly for the reaction with the higher activation energy.

The effect of activation energy on spore and nutrient destruction.

Sterilization

Thus, considering the difference between activation energies for spore destruction and nutrient degradation, an increase in temperature would accelerate spore destruction more than medium denaturation.

Sterilization

Thus, it would appear to be advantageous to employ a high temperature for a short time to achieve the desired probability of sterility, yet causing minimum nutrient degradation.

Therefore, the ideal technique would be to heat the fermentation medium to a high temperature, at which it is held for a short period, before being cooled rapidly to the fermentation temperature.

However, it is obviously impossible to heat a batch of many thousands of litres of broth in a tank to a high temperature, hold for a short period and cool without the heating and cooling periods contributing considerably to the total sterilization time.

Sterilization

The only practical method of materializing the objective of a short-time, **high-temperature treatment is to sterilize the medium in a continuous stream.**

END

Lesson No.66

MEDIUM Sterilization-7

Sterilization

The relative merits of batch and continuous sterilization may be summarized as follows:

□ *Advantages of continuous sterilization over batch sterilization*

- i. **Superior maintenance of medium quality.**
- ii. **Ease of scale-up - discussed later.**
- iii. **Easier automatic control.**
- iv. **The reduction of surge capacity for steam.**
- v. **The reduction of sterilization cycle time.**
- vi. **Under certain circumstances, the reduction fermenter corrosion.**

Sterilization

❑ *Advantages of batch sterilization over continuous sterilization*

- i. Lower capital equipment costs.**
- ii. Lower risk of contamination - processes require the aseptic transfer of the sterile broth to the sterile vessel.**
- iii. Easier manual control.**
- iv. Easier to use with media containing a high proportion of solid matter.**

The early continuous sterilizers were constructed as plate heat exchangers and these were unsuitable on two accounts:

- i. Failure of the gaskets between the plates resulted in the mixing of sterile and unsterile streams.**
- ii. Particulate components in the media would block the heat exchangers.**

Sterilization

However, modern continuous sterilizers use double spiral heat exchangers in which the two streams are separated by a continuous steel division. Also, the spiral exchangers are far less susceptible to blockage.

But a major limitation to the adoption of continuous sterilization was the precision of control necessary for its success.

This precision has been achieved with the development of sophisticated computerized monitoring and control systems resulting in continuous sterilization being very widely used and it is now the method of choice.

Sterilization

Nevertheless, batch sterilization is still used in many fermentation plants; and will be discussed in later modules.

END

Advances in Fermentation Technology

Lesson No.67

MEDIUM
Sterilization:
THE DESIGN OF
BATCH STERILIZATION
PROCESSES

Sterilization

Although a batch sterilization process is less successful in avoiding the destruction of nutrients than a continuous one, the objective in designing a batch process is still to achieve the required probability of obtaining sterility with the minimum loss of nutritive quality. The highest temperature which appears to be feasible for batch sterilization is **121°C** so the procedure should be designed such that exposure of the medium to this temperature is kept to a minimum.

This achieved by taking into account the contribution made to the sterilization by the heating and cooling periods of the batch treatment.

Sterilization

Deindoerfer and Humphrey (1959) presented a method to assess the contribution made by the heating and cooling periods. The following information must be available for the design of a batch sterilization process:

- i. A profile of the increase and decrease in the temperature of the fermentation medium during the heating and cooling periods of the sterilization cycle.
- ii. The number of micro-organisms originally present in the medium.
- iii. The thermal death characteristics of the 'design' organism. As explained earlier this may be *Bacillus stearothermophilus* or an alternative organism relevant to the particular fermentation.

Sterilization

Knowing the original number of organisms present in the fermenter and the risk of contamination considered acceptable, the required Del factor may be calculated. A frequently adopted risk of contamination is 1 in 1000, which indicates that N_t should equal 10^{-3} of a viable cell. It is worth reinforcing at this stage that we are considering the total number of organisms present in the medium and not the concentration. If a specific case is considered where the unsterile broth was shown to contain 10^{11} viable organisms, then the **Del factor** may be calculated, thus:

$$\nabla = \ln (10^{11}/10^{-3})$$

$$\nabla = \ln 10^{14}$$

$$= 32.2$$

Sterilization

Therefore, the overall **Del factor required is 32.2**. However, the destruction of cells occurs during the heating and cooling of the broth as well as during the period at 121°C , thus, the overall Del factor may be represented as:

$$\nabla_{\text{overall}} = \nabla_{\text{heating}} + \nabla_{\text{holding}} + \nabla_{\text{cooling}}$$

Knowing the temperature-time profile for the heating and cooling of the broth (prescribed by the characteristics of the available equipment) it is possible to determine the contribution made to the overall Del factor by these periods.

Sterilization

Thus, knowing the Del factors contributed by heating and cooling, the holding time may be calculated to give the required overall Del factor.

END

Advances in Fermentation Technology

Lesson No.68

MEDIUM
Sterilization:
CALCULATION OF
'DEL FACTOR'
DURING HEATING
AND COOLING

Sterilization

The relationship between Del factor, the temperature and time is given by following equation:

$$\nabla = A \cdot t \cdot e^{-(E/RT)}$$

However, during the heating and cooling periods the temperature is not constant and, therefore, the calculation of ∇ would require the integration of above equation for the time-temperature regime observed.

Deindoerfer and Humphrey (1959) produced integrated forms of the equation for a variety of temperature-time profiles, including linear, exponential and hyperbolic. However, the regime observed in practice is frequently difficult to classify, making the application of these complex equations problematical.

Sterilization

Richards (1968) demonstrated the use of a graphical method of integration and this is illustrated in Figure (on next slide). The time axis is divided into a number of equal increments, t_1, t_2, t_3 , etc., Richards suggesting 30 as a reasonable number.

Sterilization

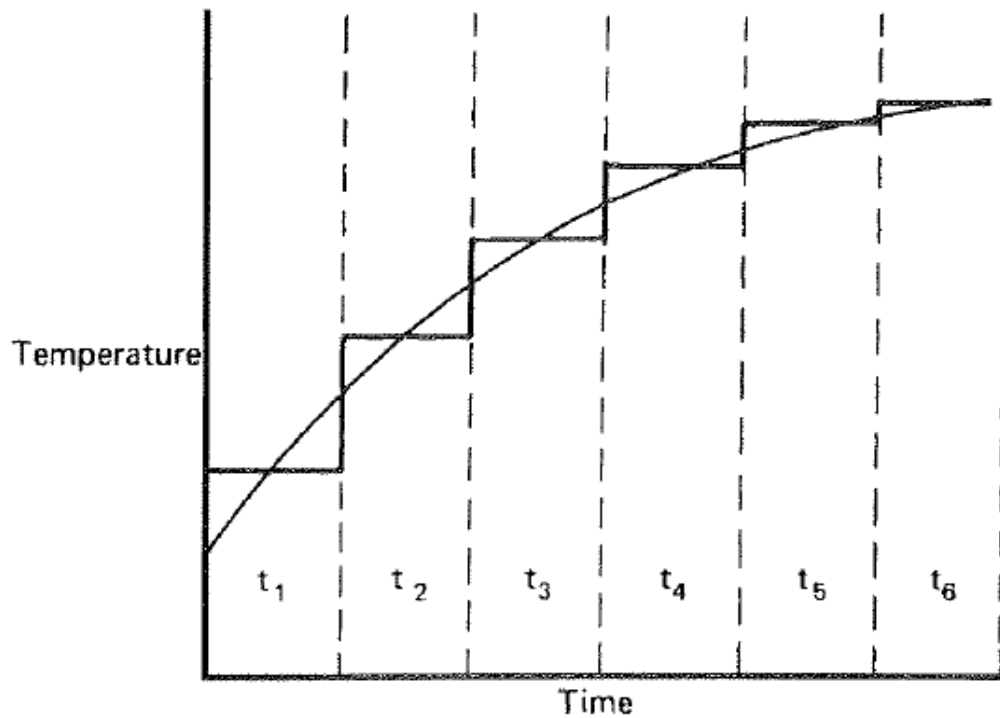

The graphical integration method applied to the increase in temperature over a time period. t_1 , t_2 , etc. represent equal time intervals

Sterilization

For each increment, the temperature corresponding to the mid-point time is recorded. It may now be approximated that the total Del factor of the heating-up period is equivalent to the sum of the Del factors of the mid-point temperatures for each time increment.

The value of the specific death rate of *Bacillus stearothermophilus* spores at each mid-point temperature may be deduced from the Arrhenius equation using the thermal death characteristic published by Deindoerfer and Humphrey (1959).

The value of the Del factor corresponding to each time increment may then be calculated from the equations:

$$\nabla_1 = k_1 t, \quad \nabla_2 = k_2 t, \quad \nabla_3 = k_3 t, \quad \text{etc.}$$

Sterilization

The sum of the Del factors for all the increments will then equal the Del factor for the heating-up period.

The Del factor for the cooling-down period may be calculated in a similar fashion.

END

Advances in Fermentation Technology

Lesson No.69

MEDIUM
Sterilization:
CALCULATION OF
'HOLDING TIME'
AT
CONSTANT TEMP.

Sterilization

From the previous calculations (in last module) the overall Del factor, as well as the Del factors of the heating and cooling parts of the cycle, have been determined. Therefore, the Del factor to be achieved during the holding time may be calculated by difference:

$$\nabla_{\text{holding}} = \nabla_{\text{overall}} - \nabla_{\text{heating}} - \nabla_{\text{cooling}}$$

Using our example where the overall Del factor is 32.2 and if it is taken that the heating Del factor was 9.8 and the cooling Del factor 10.1, the holding Del factor may be calculated:

$$\nabla_{\text{holding}} = 32.2 - 9.8 - 10.1,$$

$$\nabla_{\text{holding}} = 12.3.$$

Sterilization

But $\nabla = kt$, and from the data of Deindorfer and Humphrey (1961) the **specific death rate** of *B. stearothermophilus* spores at **121°C is 2.54 min⁻¹**.

Therefore, $t = \nabla/k$ or $t = 12.3/2.54 = 4.84$ min.

If the contribution made by the heating and cooling parts of the cycle were ignored then the holding time would be given by the equation:

$$t = \nabla_{\text{overall}}/k = 32.2/2.54 = 12.68 \text{ min}$$

Sterilization

Thus, by considering the contribution made to the sterilization process by the heating and cooling parts of the cycle a considerable reduction in exposure achieved.

END

Advances in Fermentation Technology

Lesson No.70

MEDIUM
Sterilization:
Richards' RAPID
METHOD FOR
DESIGNING OF
STERILIZATION
CYCLES

Sterilization

Richards (1968) proposed a rapid method for the design of sterilization cycles avoiding the time consuming graphical integrations. The method assumes that all spore destruction occurs at temperatures above 100°C and that those parts of the heating and cooling cycle above 100°C are linear. Both these assumptions reasonably valid and the technique loses very little in accuracy and gains considerably in simplicity.

Furthermore, based on these assumptions, Richards has presented a table of Del factors for *B. stearothermophilus* spores which would be obtained in heating and cooling a broth up to (and down from) holding temperatures of 101-130°C, based on a temperature change of 1°C per minute. This information is presented in Table (on next slide), together with the specific death rates for *B. stearothermophilus* spores over the temperature range.

Sterilization

T (°C)	k (min ⁻¹)	∇
100	0.019	—
101	0.025	0.044
102	0.032	0.076
103	0.040	0.116
104	0.051	0.168
105	0.065	0.233
106	0.083	0.316
107	0.105	0.420
108	0.133	0.553
109	0.168	0.720
110	0.212	0.932
111	0.267	1.199
112	0.336	1.535
113	0.423	1.957
114	0.531	2.488
115	0.666	3.154

Sterilization

116	0.835	3.989
117	1.045	5.034
118	1.307	6.341
119	1.633	7.973
120	2.037	10.010
121	2.538	12.549
122	3.160	15.708
123	3.929	19.638
124	4.881	24.518
125	6.056	30.574
126	7.506	38.080
127	9.293	47.373
128	11.494	58.867
129	14.200	73.067
130	17.524	90.591

Sterilization

If the rate of temperature change is 1° per minute, the Del factors for heating and cooling may be read directly from the table; if the temperature change deviates from 1° per minute, the Del factors may be altered by simple proportion.

For example, if a fermentation broth were heated from 100° to 121°C in 30 minutes and cooled from 121° to 100° in 17 minutes, the Del factors for the heating and cooling cycles may be determined as follows:

From Table (in previous two slides), if the change in temperature had been 1° per minute, the Del factor for both the heating and cooling cycles would be 12.549. But the temperature change in the heating cycle was 21° in 30 minutes; therefore,

$$\text{Del}_{\text{heating}} = (12.549 \times 30) / 21 = 17.93$$

Sterilization

and the temperature change in the cooling cycle was 21° in 17 minutes, therefore,

$$\begin{aligned} \text{Del}_{\text{cooling}} &= (12.549 \times 17) / 21 \\ &= 10.16. \end{aligned}$$

Sterilization

Having calculated the Del factors for the heating and cooling periods the holding time at the constant temperature may be calculated as before.

END

www.vaCTn.com

BIO204 Complete MERGED

PPT Slides 1 TO 91

Regards : Zarva Chaudhary

Merged File date 2021

Admin:

* Zarva Chaudhary *

Chandhary Moazzam

* Laiba Maki *

Advances in Fermentation Technology

Lesson No.71

MEDIUM

Sterilization:

THE SCALE-UP OF
BATCH
STERILIZATION
PROCESSES

Sterilization

The use of the Del factor in the scale up of batch sterilization processes has been discussed by Banks (1979). It should be appreciated by this stage that the Del factor does not include a volume term, i.e. absolute numbers of contaminants and survivors are considered, not their concentration.

Thus, if the size of a fermenter is increased the initial number of spores in the medium will also be increased, but if the same probability of achieving sterility is required the final spore number should remain the same, resulting in an increase in the Del factor.

Sterilization

For example, if a pilot sterilization were carried out in a 1000 dm³ vessel with a medium containing 10⁶ organisms cm⁻³ requiring a probability of contamination of 1 in 1000, the Del factor would be:

$$\begin{aligned} \nabla &= \ln \{ (10^6 \times 10^3 \times 10^3) / 10^{-3} \} \\ &= \ln (10^{12} / 10^{-3}) \\ &= \ln 10^{15} = 34.5. \end{aligned}$$

If the same probability of contamination were required in a 10,000 dm³ vessel using the same medium the Del factor would be:

$$\begin{aligned} \nabla &= \ln \{ (10^6 \times 10^3 \times 10^4) / 10^{-3} \} \\ &= \ln (10^{13} / 10^{-3}) \\ &= \ln 10^{16} = 36.8. \end{aligned}$$

Sterilization

Thus, the Del factor increases with an increase in the size of the fermenter volume. The holding time in the large vessel may be calculated by the graphical integration method or by the rapid method of Richards (1968), as discussed in last module, based on the temperature-time profile of the sterilization cycle in the large vessel.

However, it must be appreciated that extending the holding time on the larger scale (to achieve the increased ∇ factor) will result in increased nutrient degradation. Also, the contribution of the heating-up and cooling-down periods to nutrient destruction will be greater as scale increases.

Sterilization

Maintaining the same nutrient quality on a small and a large scale can be achieved in batch sterilization only by compromising the sterility of the vessel, which is totally unacceptable.

Sterilization

Thus, the decrease in the yield of a fermentation when it is scaled up is often due to problems of nutrient degradation during batch sterilization and the only way to eradicate the problem is to sterilize the medium continuously.

END

Advances in Fermentation Technology

Lesson No.72

**MEDIUM
Sterilization:
METHODS OF
BATCH STERILIZATION**

Sterilization

The batch sterilization of the medium for a fermentation may be achieved either in the fermentation vessel or in a separate mash cooker. Richards (1966) considered the relative merits of *in situ medium sterilization* and the use of a special vessel. The major advantages of a separate medium sterilization vessel may be summarized as:

- i. One cooker may be used to serve several fermenters and the medium may be sterilized as the fermenters are being cleaned and prepared for the next fermentation, thus saving time between fermentations.
- ii. The medium may be sterilized in a cooker in a more concentrated form than would be used in the fermentation and then diluted in the fermenter with sterile water prior to inoculation. This would allow the construction of smaller cookers.

Sterilization

- iii. In some fermentations, the medium is at its most viscous during sterilization and the power requirement for agitation is not alleviated by aeration as it would be during the fermentation proper. Thus, if the requirement for agitation during *in situ sterilization* were removed, the fermenter could be equipped with a less powerful motor. Obviously, the sterilization kettle would have to be equipped with a powerful motor, but this would provide sterile medium for several fermenters.
- iv. The fermenter would be spared the corrosion which may occur with medium at high temperature.

Sterilization

The major disadvantages of a separate medium sterilization vessel may be summarized as:

- i. **The cost of constructing a batch medium sterilizer is much the same as that for the fermenter.**
- ii. **If a cooker serves a large number of fermenters complex pipework would be necessary to transport the sterile medium, with the inherent dangers of contamination.**
- iii. **Mechanical failure in a cooker supplying medium to several fermenters would render all the fermenters temporarily redundant. The provision of contingency equipment may be prohibitively costly.**

Sterilization

Overall, the pressure to decrease **the 'down time'** between fermentations has tended to outweigh the perceived disadvantages of using separate sterilization vessels. Thus, sterilization in dedicated vessels is the method of choice for batch sterilization.

END

Lesson No.73

MEDIUM

Sterilization:

**THE DESIGN OF
CONTINUOUS
STERILIZATION
PROCESSES-1**

Sterilization

The design of continuous sterilization cycles may be approached in exactly the same way as for batch sterilization systems. **The continuous system includes a time period during which the medium is heated to the sterilization temperature, a holding time at the desired temperature and a cooling period to restore the medium to the fermentation temperature.**

The temperature of the medium is elevated in a continuous heat exchanger and is then maintained in an insulated serpentine holding coil for the holding period.

The length of the holding period is dictated by the length of the coil and the flow rate of the medium.

Sterilization

The hot medium is then cooled to the fermentation temperature using two sequential heat exchangers - the first utilizing the in-coming medium as the cooling source (thus conserving heat by heating-up the incoming medium) and the second using cooling water. The major advantage of the continuous process is that a much higher temperature may be utilized, thus reducing the holding time and reducing the degree of nutrient degradation.

The required Del factor may be achieved by the combination of temperature and holding time which gives acceptably small degree of nutrient decay.

Sterilization

The **Del factor** for the example sterilization was **45.7** and the following temperature time regimes were calculated to give the same Del factor:

Temperature	Holding time
130°	2.44 minutes
135°	51.9 seconds
140°	18.9 seconds
150°	2.7 seconds

Furthermore, because a continuous process involves treating small increments of medium the heating-up and cooling-down periods are very small compared with those in a batch system.

Sterilization

There are two types of continuous sterilizer which may be used for the treatment of fermentation media: **the indirect heat exchanger** and **the direct heat exchanger (steam injector)**.

END

Advances in Fermentation Technology

Lesson No.74

MEDIUM
Sterilization:
THE DESIGN OF
CONTINUOUS
STERILIZATION
PROCESSES-2

Sterilization

The most suitable indirect heat exchangers are of the double-spiral type which consists of two sheets of high-grade stainless steel which have been curved around a central axis to form a double spiral, as shown in following Figure. The ends of the spiral are sealed by covers.

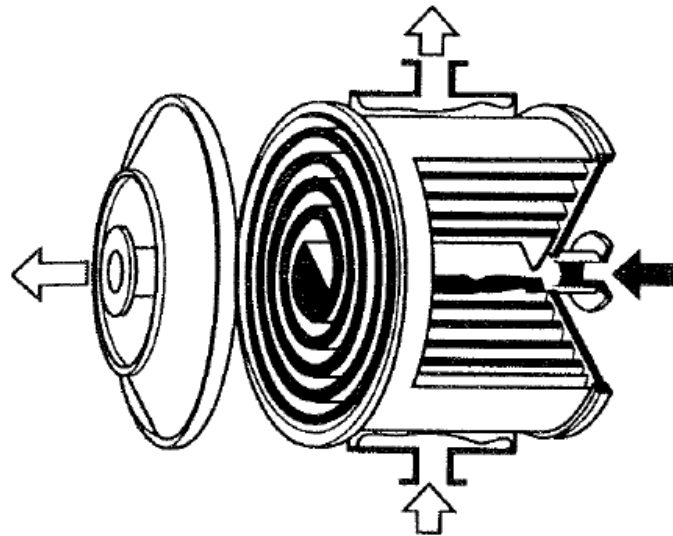

Sterilization

To achieve sterilization temperatures steam is passed through one spiral and medium through the other in countercurrent streams. Spiral heat exchangers are also used to cool the medium after passing through the holding coil. Incoming unsterile medium is used as the cooling agent in the first cooler so that the incoming medium is partially heated before it reaches the sterilizer and, thus, heat is conserved. The major advantages of the spiral heat exchanger are:

- i. The two streams of medium and cooling liquid, or medium and steam, are separated by a continuous stainless steel barrier with gasket seals being confined to the joints with the end plates. This makes cross contamination between the two streams unlikely.

Sterilization

ii. The spiral route traversed by the medium allows sufficient clearances to be incorporated for the system to cope with suspended solids. The exchanger tends to be self-cleaning which reduces the risk of sedimentation, fouling and 'burning-on'.

END

Advances in Fermentation Technology

Lesson No.75

MEDIUM
Sterilization:
THE DESIGN OF
CONTINUOUS
STERILIZATION
PROCESSES-3

Sterilization

Indirect plate heat exchangers consist of alternating plates through which the countercurrent streams are circulated. The plates are separated by gaskets and failure of these gaskets can cause cross-contamination between the two streams. Also, the clearances between the plates are such that suspended solids in the medium may block the exchanger and, thus, the system is only useful in sterilizing completely soluble media. However, the plate exchanger is more adaptable than the spiral system in that extra plates may be added to increase its capacity.

The continuous steam injector injects steam directly into the unsterile broth. The advantages and disadvantages of the system have been summarized by Banks (1979):

Sterilization

- i. Very short (almost instantaneous) heating up times.
- ii. It may be used for media containing suspended solids.
- iii. **Low capital cost.**
- iv. **Easy cleaning and maintenance.**
- v. **High steam utilization efficiency.**

However, the disadvantages are:

- i. **Foaming may occur during heating.**
- ii. Direct contact of the medium with steam requires that allowance be made for condense dilution and requires 'clean' steam, free from anticorrosion additives.

In some cases the injection system is combined with flash cooling, where the sterilized medium is cooled by passing it through an expansion valve into a vacuum chamber. Cooling then occurs virtually instantly.

Sterilization

A flow chart of a continuous sterilization system using direct steam injection is shown in following Figure:

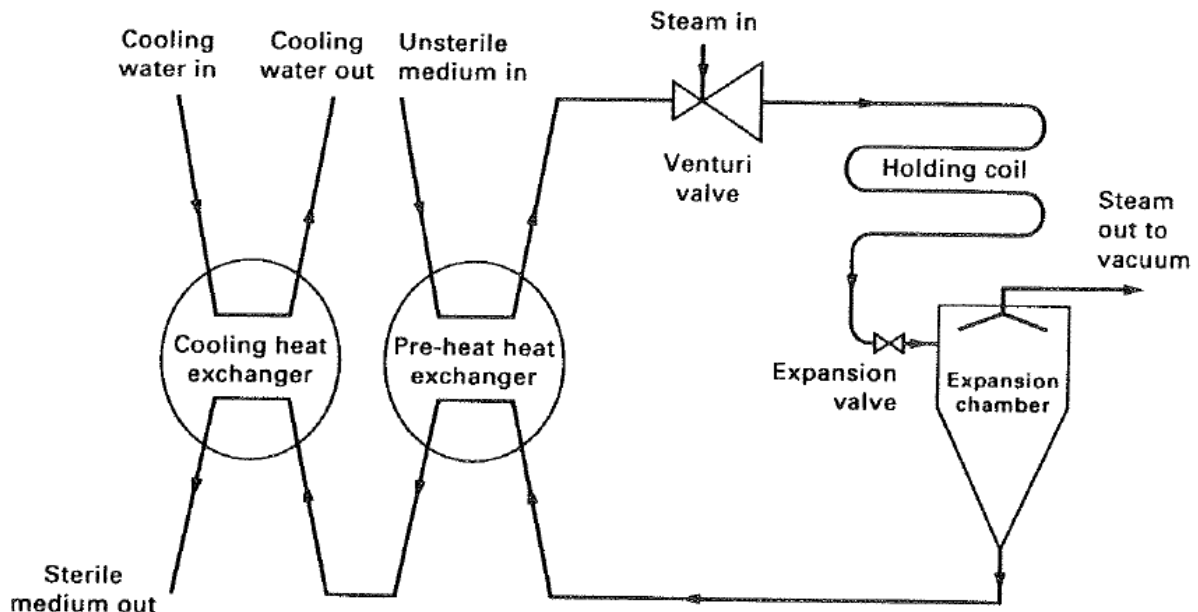

Flow diagram of a typical continuous injector-flash cooler sterilizer

Sterilization

In some cases a combination of direct and indirect heat exchangers may be used. This is especially true for starch-containing broths when steam injection is used for the pre-heating step.

Sterilization

By raising the temperature virtually instantaneously the critical gelatinization temperature of the starch is passed through very quickly and the increase in viscosity normally associated with heated starch colloids can be reduced.

END

Advances in Fermentation Technology

Lesson No.76

Sterilization
of the FERMENTER,
FEEDS, and of
LIQUID WASTES

Sterilization

☐ Sterilization of the Fermenter

If the medium is sterilized in a separate batch cooker, or is sterilized continuously, then the fermenter has to be sterilized separately before the sterile medium is added to it. This is normally achieved by heating the jacket or coils of the fermenter with steam and sparging steam into the vessel through all entries, apart from the air outlet from which steam is allowed to exit slowly. **Steam pressure is held at 15 psi in the vessel for approximately 20 minutes.** It is essential that sterile air is sparged into the fermenter after the cycle is complete and a positive pressure is maintained; otherwise a vacuum may develop and unsterile air be drawn into the vessel.

Sterilization

☐ Sterilization of the Feeds

A variety of additives may be administered to a fermentation during the process and it is essential that these materials are sterile. **The sterilization method depends on the nature of the additive, and the volume and feed rate at which it is administered.** **If the additive is fed in large quantities then continuous sterilization may be desirable.** **Batch sterilization of feed liquids normally involves steam injection into the material held in storage vessels.** Whatever the sterilization system employed it is essential that all ancillary equipment and feed pipework associated with the additions are sterilizable.

Sterilization

□ Sterilization of the Liquid Wastes

Process organisms which have been engineered to produce 'foreign' products and therefore contain heterologous genes are subject to strict containment regulations. Thus, waste biomass of such organisms must be sterilized before disposal.

Sterilization may be achieved by either batch or continuous means but the whole process must be carried out under contained conditions.

Batch sterilization involves the sparging of steam into holding tanks, whereas continuous processes would employ the type of heat exchangers.

Sterilization

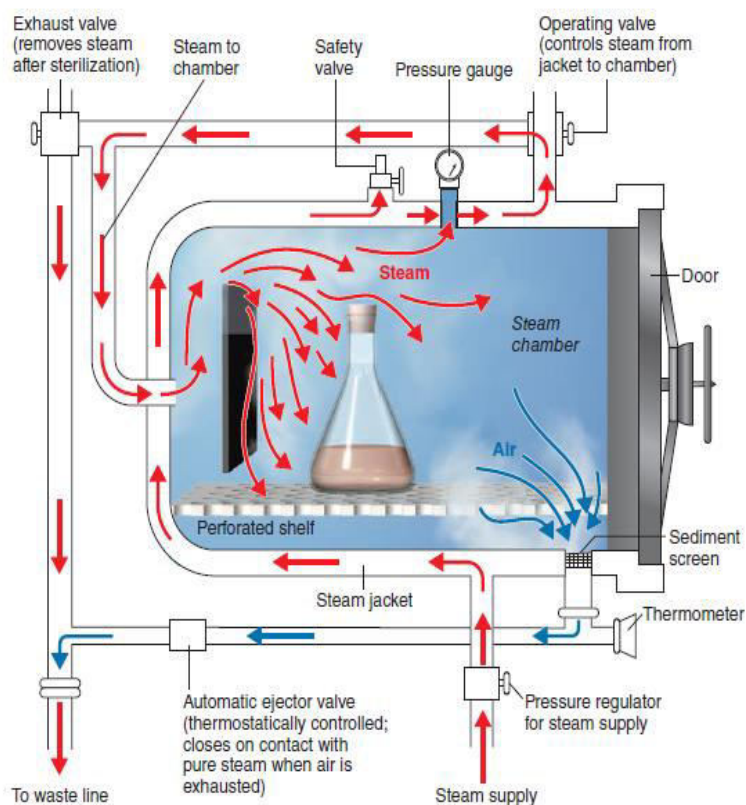

An autoclave. The entering steam forces the air out of the bottom (blue arrows). The automatic ejector valve remains open as long as an air-steam mixture is passing out of the waste line. When all the air has been ejected, the higher temperature of the pure steam closes the valve, and the pressure in the chamber increases.

Sterilization

A holding vessel for the batch sterilization of waste is shown in Figure on next slide. **Whichever method is employed the effluent must be cooled to below 60°C before it is discharged to waste. The sterilization processes have to be validated and are designed using the Del factor approach.**

However, the kinetic characteristics used in the calculations would be those of the process organism rather than of *B. stearothermophilus*. Also, the N_t value used in the design calculations would be smaller than 10^{-3} which is used for medium sterilization and would depend on the assessment of the hazard involved should the organism survive the decontamination process.

Sterilization

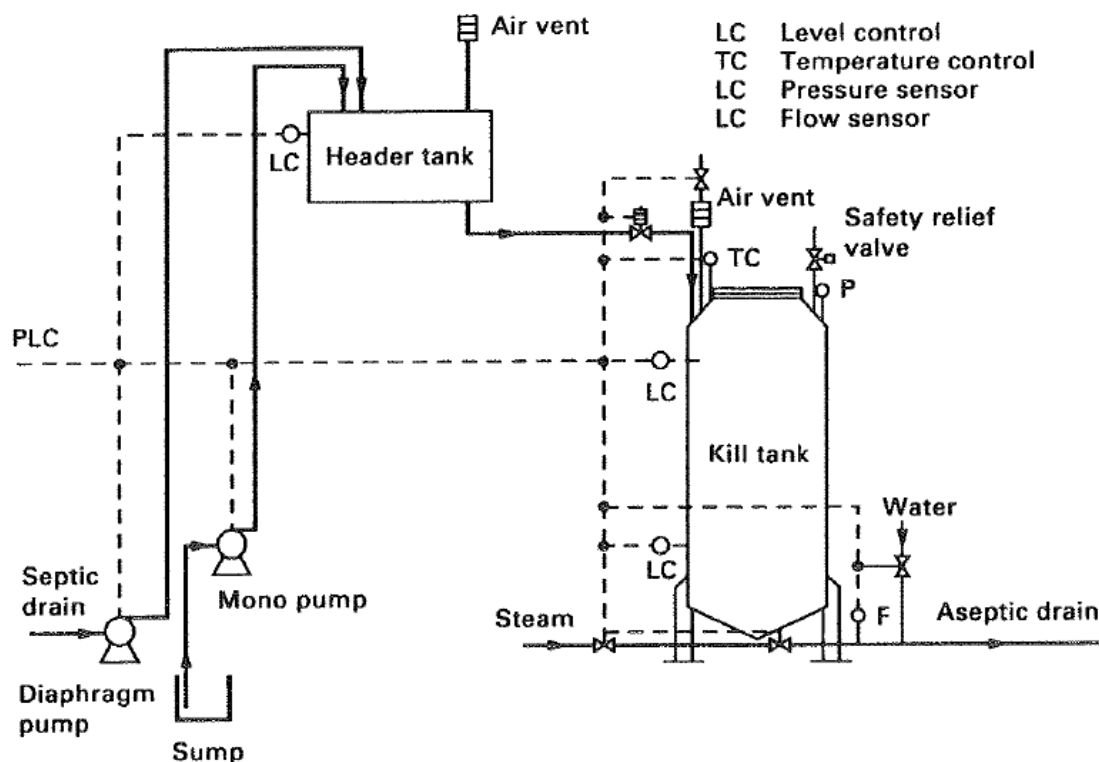

A vessel for the batch sterilization of liquid waste from a contained fermentation

Sterilization

Thus, the sterilization regime used for destruction of the process organism will be different from that used in sterilizing the medium.

END

Advances in Fermentation Technology

Lesson No.77

FILTER
Sterilization

Sterilization

Suspended solids maybe separated from a fluid during filtration by the following mechanisms:

- i. Inertial impaction.*
- ii. Diffusion.*
- iii. Electrostatic attraction.*
- iv. Interception.*

Sterilization

☐ Inertial Impaction

Suspended particles in a fluid stream have momentum. The fluid in which the particles are suspended will flow through the filter by the route of least resistance. However, the particles, because of their momentum, tend to travel in straight lines and may therefore become impacted upon the fibers where they may then remain. Inertial impaction is more significant in the filtration of gases than in the filtration of liquids.

☐ Diffusion

Extremely small particles suspended in a fluid are subject to Brownian motion which is random movement due to collisions with fluid molecules. Thus, such small particles tend to deviate from the fluid flow pattern and may be come impacted upon the filter fibers. Diffusion is more significant in the filtration of gases than in the filtration of liquids.

Sterilization

❑ Electrostatic attraction

Charged particles may be attracted by opposite charges on the surface of the filtration medium.

❑ Interception

The fibers comprising a filter are interwoven to define openings of various sizes. Particles which are larger than the filter pores are removed by direct interception. However, a significant number of particles which are smaller than the filter pores are also retained by interception. This may occur by several mechanisms – more than one particle may arrive at a pore simultaneously, an irregularly shaped particle may bridge a pore, once a particle has been trapped by a mechanism other than interception the pore may be partially occluded enabling the entrapment of smaller particles. Interception is equally important a mechanism in the filtration of gases and liquids.

Sterilization

Filters have been classified into two types – those in which the pores in the filter are smaller than the particles which are to be removed and those in which the pores are larger than the particles which are to be removed.

END

Lesson No.78

FILTER Sterilization OF FERMENTATION MEDIA

Sterilization

Media for animal-cell culture cannot be sterilized by steam because they contain heat-labile proteins. Thus, filtration is the method of choice and fixed pore or absolute filtration is the better system to use. **An ideal filtration system for the sterilization of animal cell culture media must fulfill the following criteria:**

- i. The filtered medium must be free of fungal, bacterial and mycoplasma contamination.*
- ii. There should be minimal adsorption of protein to the filter surface.*
- iii. The filtered medium should be free of viruses.*
- iv. The filtered medium should be free of bacterial endotoxins.*

Sterilization

Several filter manufacturers now supply absolute filtration systems for the sterilization of animal cell culture medium. Such systems consist of membrane cartridges which are fitted into stainless steel, steam sterilizable modules. **The membranes for media filtration are constructed from steam sterilizable hydrophilic material and are treated to produce a filtrate of particular quality.** For example, if minimal protein adsorption is a major criterion then a specially coated filter membrane is used. It would be very difficult to construct a single filtration membrane which would fulfill all four criteria cited above. **Thus, a series of filters are used to achieve the desired result.**

Sterilization

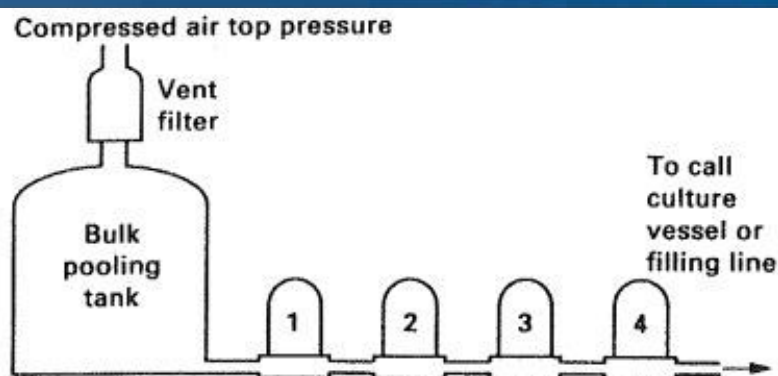

Figure representing the Filtration system for the provision of sterile, Mycoplasma free serum (Pall Process Filtration Ltd., Portsmouth, U.K.).

Filter 1.	5μm absolute rated pre-filter for removal of coarse precipitates.
Filter 2.	0.5μm absolute rated pre-filter for bulk bioburden removal.
Filter 3.	0.1μm absolute rated single layer pre-filter for further bioburden and endotoxin removal.
Filter 4.	0.1μm absolute rated double layer final filter for absolute sterility, mycoplasma removal and further endotoxin control.

Sterilization

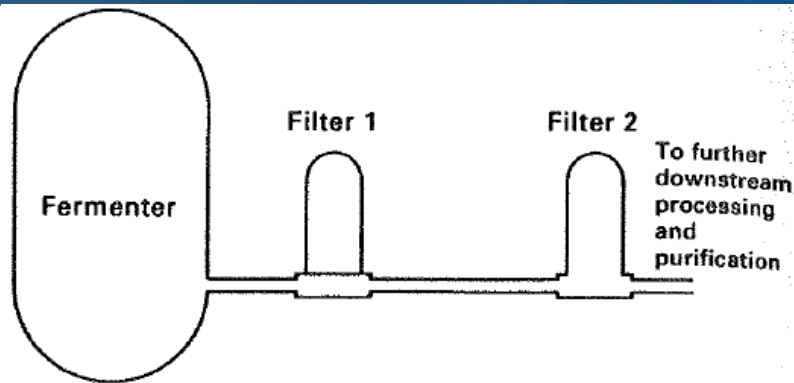

Figure representing the Filtration system for the removal of cells and cell debris from an animal cell culture fermentation. (Pall Process Filtration Ltd., Portsmouth, U.K.).

Filter 1.	1.0μm absolute rated prefilter for bulk cell and cell debris removal.
Filter 2.	0.2μm absolute rated single layer 'Bio-Inert' filter for final bioburden removal.

Sterilization

The pre-filter used in figure shown in previous slide is a polypropylene 1.0 μ m rated filter to remove the bulk of the cells and debris and the second filter is an hydroxyl modified nylon/polyester 0.2- μ m rated filter giving absolute cell removal with minimal protein adsorption.

END

Lesson No.79

FILTER Sterilization OF FERMENTATION AIR

Sterilization

Aerobic fermentations require the continuous addition of considerable quantities of sterile air. Although it is possible to sterilize air by heat treatment, the most commonly used sterilization process is filtration. **Fixed pore filters (which have an absolute rating) are very widely used in the fermentation industry and several manufacturers produce filtration systems for air sterilization. These systems, like those for the sterilization of liquids, consist of pleated membrane cartridges designed to be accommodated in stainless steel modules. The most common construction material used for the pleated membranes for air sterilization is Polytetrafluoroethylene (PTFE), which is hydrophobic and is therefore resistant to wetting.**

Sterilization

Also, PTFE filters may be steam sterilized and are resistant to ammonia which may be injected into the air stream, prior to the filter, for pH control. As for the filter sterilization of liquids it is essential that a prefilter is incorporated up-stream of the absolute filter. The prefilter traps large particles such as dust, oil and carbon (from the compressor) and pipescale and rust (from the pipework). The use of a coalescing prefilter also ensures the removal of water from the air; entrained water is coalesced in the filter (air flow being from the inside of the filter to the outside) and is discharged via an automatic drain.

Sterilization



END

Lesson No.80

Sterilization OF FERMENTER EXHAUST AIR

Sterilization

In many traditional fermentations the exhaust gas from the fermenter was vented without sterilization or vented through relatively inefficient depth filters. With the advent of the use of recombinant organisms and a greater awareness of safety and emission levels of allergic compounds the containment of exhaust air is more common (and in the case of recombinant organisms, compulsory). Fixed pore membrane modules are also used for this application but the system must be able to cope with the sterilization of water saturated air, at a relatively high temperature and carrying a large contamination level. Also, foam may overflow from the fermenter into the air exhaust line.

Sterilization

Thus, some form of pretreatment of the exhaust gas is necessary before it enters the absolute filter. This pretreatment may be a hydrophobic prefilter or a mechanical separator to remove water, aerosol particles and foam.

The pretreated air is then fed to a 0.2 μ m hydrophobic filter. Again, it is important to appreciate that the filtration system must be steam sterilizable. Figures in next slides illustrate the prefilter and mechanical separator systems respectively.

Sterilization

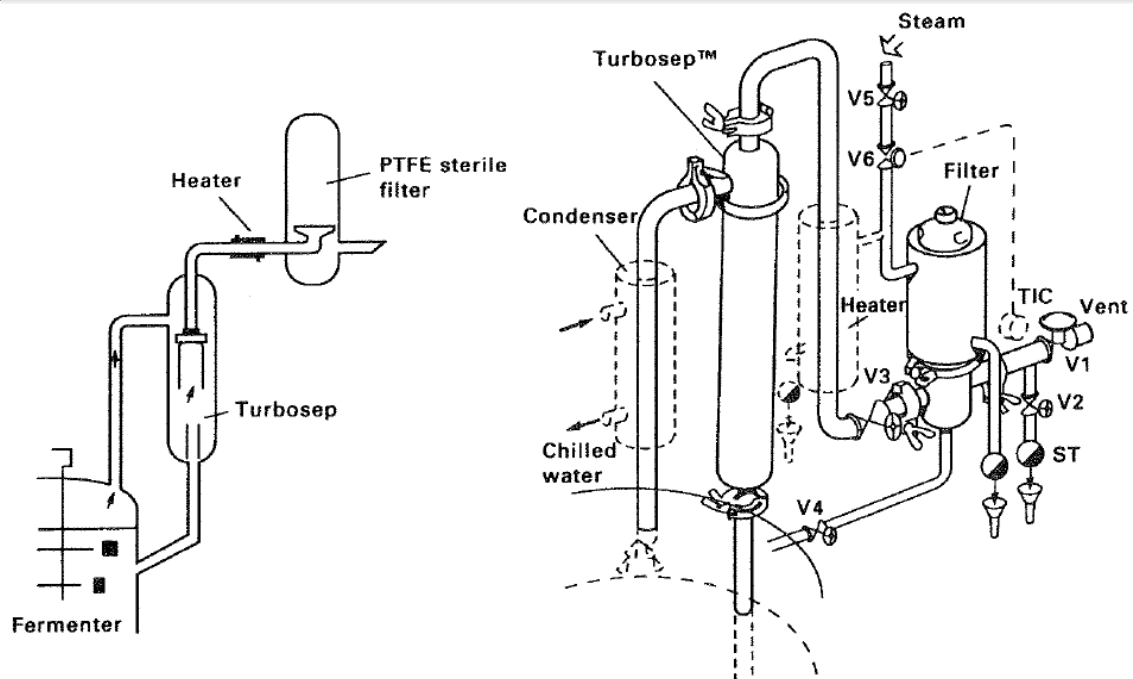

A mechanical separator and hydrophobic filter system for the sterilization of off-gas from a fermenter. Left. Cut-away diagram. Right. Equipment arrangement, showing steam supply. VI-V6, valves; O, steam, traps

Sterilization

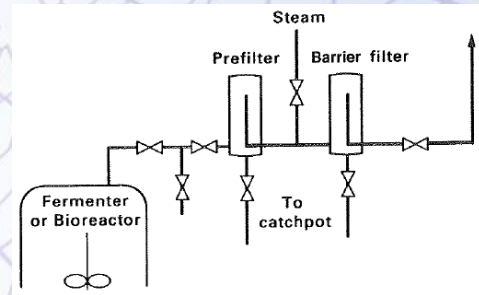

Figure showing Dual hydrophobic filter system for the sterilization of off-gas from a fermenter.

END

Advances in Fermentation Technology

Lesson No.81

Recovery and Purification of Fermentation Products-1

Recovery & Purification of Fermentation Products

- The extraction and purification of fermentation products may be **difficult and costly**. Ideally, one tries to obtain a high-quality product as quickly as possible at an efficient recovery rate using minimum plant investment operated at minimal costs.
- Unfortunately, recovery costs of microbial products may vary from as low as **15%** to as high as **70%** of the total **manufacturing costs**.

Recovery & Purification of Fermentation Products

- If a fermentation broth is analysed at the time of harvesting it will be discovered that the specific product may be present at a low concentration in an aqueous solution that contains **intact micro-organisms**, **cell fragments**, **soluble and insoluble medium components** and **other metabolic products**.
- The product may also be **intracellular**, **heat labile** and easily broken down by contaminating micro-organisms. **All these factors tend to increase the difficulties of product recovery**.

Recovery & Purification of Fermentation Products

To ensure good recovery or purification, speed of operation may be the over-riding factor because of the labile nature of a product.

END1

Advances in Fermentation Technology

Lesson No.82

**Recovery and
Purification
of
Fermentation
Products-2**

Recovery & Purification of Fermentation Products

The processing equipment must therefore be of the correct type and also the correct size to ensure that the harvested broth can be processed within a satisfactory time limit.

Recovery & Purification of Fermentation Products

The choice of recovery process is based on the following criteria:

- 1. The intracellular or extracellular location of the product.**
- 2. The concentration of the product in the fermentation broth.**
- 3. The physical and chemical properties of the desired product (as an aid to selecting separation procedures).**
- 4. The intended use of the product.**
- 5. The minimal acceptable standard of purity.**

Recovery & Purification of Fermentation Products

6. The magnitude of bio-hazard of the product or broth.
7. The impurities in the fermenter broth.
8. The marketable price for the product.

The main objective of the first stage for the **recovery of an extracellular product** is the removal of large solid particles and microbial cells usually by **centrifugation or filtration** (as shown in Fig. on next slide).

Recovery & Purification of Fermentation Products

Stages in the recovery of product from a harvested fermentation broth.

Fermentation Broth

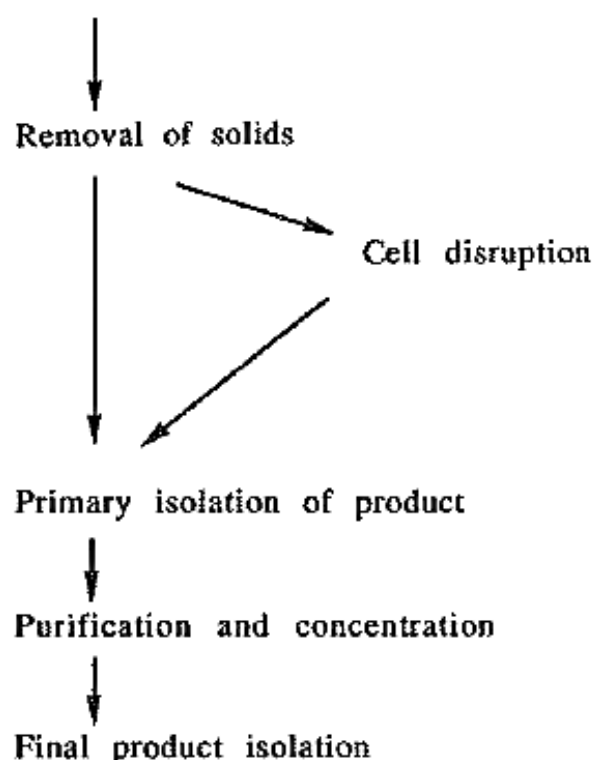

Recovery & Purification of Fermentation Products

In the next stage, the broth is fractionated or extracted into major fractions using **ultrafiltration**, reverse osmosis, **adsorption/ion-exchange/gel filtration** or **affinity chromatography**, liquid-liquid extraction, **two phase aqueous extraction** or precipitation.

Recovery & Purification of Fermentation Products

Afterwards, the product-containing fraction is purified by fractional precipitation, **further more precise chromatographic techniques** and **crystallization** to obtain a product which is highly concentrated and essentially free from **impurities**. Other products are isolated using modifications of this flow-stream.

END

Lesson No.83

Recovery and Purification of Fermentation Products-3

Recovery & Purification of Fermentation Products

It may be possible to modify the handling characteristics of the broth so that it can be handled faster with simpler equipment making use of a number techniques:

1. Selection of a micro-organism which produce pigments or undesirable metabolites.
2. Modification of the fermentation reduce the production of metabolites.
3. Precise timing of harvesting.
4. pH control after harvesting.
5. Temperature treatment after harvesting.
6. Addition of flocculating agents.
7. Use of enzymes to attack cell walls.

Recovery & Purification of Fermentation Products

The recovery and purification of many compounds may be achieved by a number of alternative routes. The decision to follow a particular route involves comparing the following factors to determine the most appropriate under a given set of circumstances (some of them are given below):

1. **Capital costs**
2. **Processing costs**
3. **Throughput requirements**
4. **Yield potential**
5. **Product quality**
6. **Technical expertise available**

Recovery & Purification of Fermentation Products

Micro-organisms and other similar sized particles can be removed from a broth by using a centrifuge when filtration is not a satisfactory separation method. Although a centrifuge may be expensive when compared with a filter it may be essential when:

1. **Filtration is slow and difficult.**
2. **The cells or other suspended matter must be obtained free of filter aids.**
3. **Continuous separation to a high standard of hygiene is required.**

Recovery & Purification of Fermentation Products

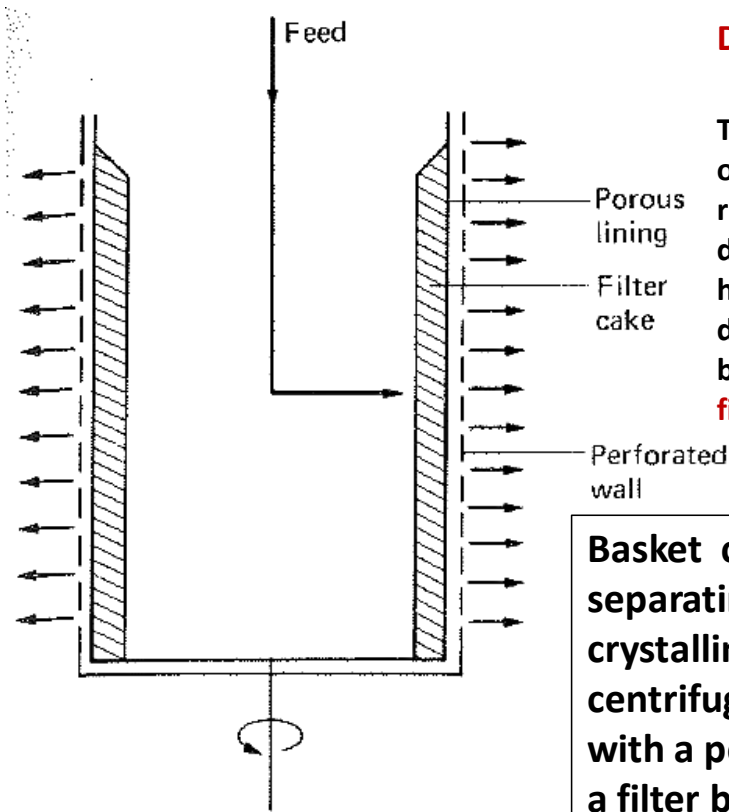

Diagram of Basket Centrifuge

These centrifuges are normally operated at speeds of up to 4000 rpm for feed rates of 50 to 300 $\text{dm}^3 \text{min}^{-1}$ and have a solids holding capacity of 30 to 500 dm^3 . The basket centrifuge may be considered to be a **centrifugal filter**.

Basket centrifuges are useful for separating mould mycelia or crystalline compounds. The centrifuge is most commonly used with a perforated bowl lined with a filter bag of nylon, cotton, etc.

Recovery & Purification of Fermentation Products

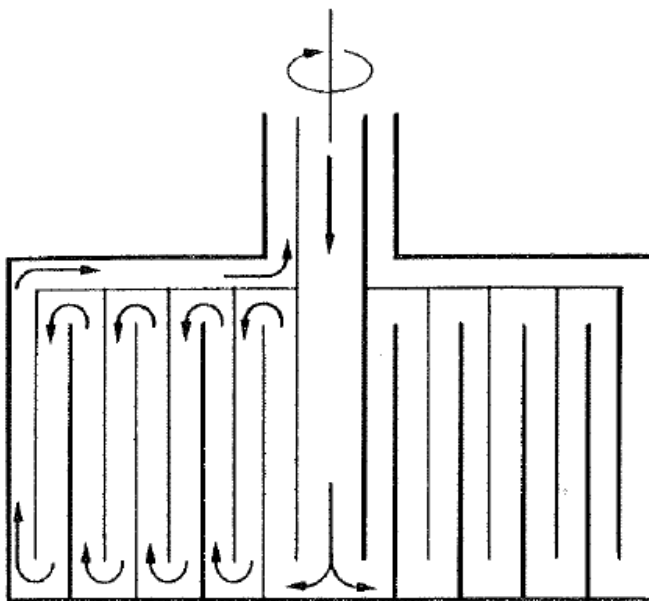

Diagram of a Multi-chamber Centrifuge

This centrifuge is used for a slurry of up to 5% solids of particle size 0.1 to 200 μm diameter. A series of concentric chambers are mounted within the rotor chamber. The broth enters via the central spindle and then takes a circuitous route through the chambers. Solids collect on the outer faces of each chamber. The smaller particles are collected in outer chambers where they are subjected to greater centrifugal forces (the greater the radial position of a particle, the greater the rate of sedimentation).

Recovery & Purification of Fermentation Products

❑ Cell Disruption

Micro-organisms are protected by extremely tough cell walls. In order to release their cellular contents a number of methods for cell disintegration have been developed. **Any potential method of disruption must ensure that labile materials are not denatured by the process or hydrolysed by enzymes present in the cell.**

Methods available fall into two major categories:

Chemical methods

- (a) Detergents.
- (b) Osmotic shock.
- (c) Alkali treatment.
- (d) Enzyme treatment.

Physico-mechanical methods

- (a) Liquid shear.
- (b) Solid shear.
- (c) Agitation with abrasives.
- (d) Freeze-thawing.
- (e) Ultrasonication.

Recovery & Purification of Fermentation Products

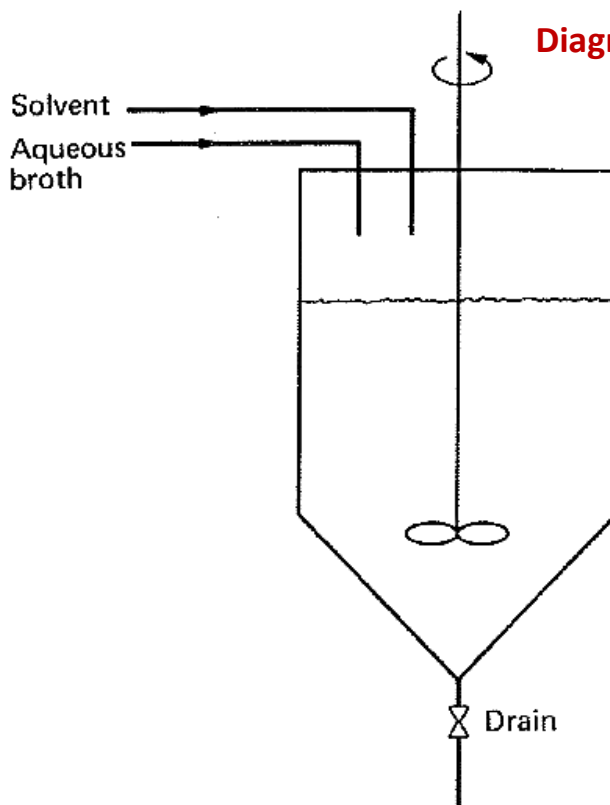

Diagram of a single-stage extraction unit

The separation of a component from a liquid mixture by treatment with a solvent in which the desired component is preferentially soluble is known as **liquid-liquid extraction**. The specific requirement is that a high percentage extraction of product must be obtained but concentrated in a smaller volume of solvent.

Recovery & Purification of Fermentation Products

A major item of equipment in an extraction process is the solvent-recovery plant which is usually a **distillation unit**. It is not normally essential to remove all the raffinate (product which has component removed) from the solvent as this will be recycled through the system.

END

Advances in Fermentation Technology

Lesson No.84

**Recovery and
Purification
of
Fermentation
Products-4**

Recovery & Purification of Fermentation Products

Drying of any product (including biological products) is often the last stage of a manufacturing process. It involves the final removal of water from a heat-sensitive material ensuring that there is minimum loss in viability, activity or nutritional value. Drying is undertaken because:

- i. **The cost of transport can be reduced.**
- ii. **The material is easier to handle and package.**
- iii. **The material can be stored more conveniently in the dry state.**

It is important that as much water as possible is removed initially by centrifugation or in a filter press to minimize heating costs in the drying process.

Recovery & Purification of Fermentation Products

Diagram of Counter-current spray drier

A spray drier is most widely used for drying of biological materials when the starting material is in the form of a liquid or paste. The material to be dried does not come into contact with the heating surfaces, instead, it is atomized into small droplets through for example a nozzle or by contact with a rotating disc. Spray driers are the most economical available handling large volumes, and it is only at feed below 6 kg min^{-1} that drum driers become economic.

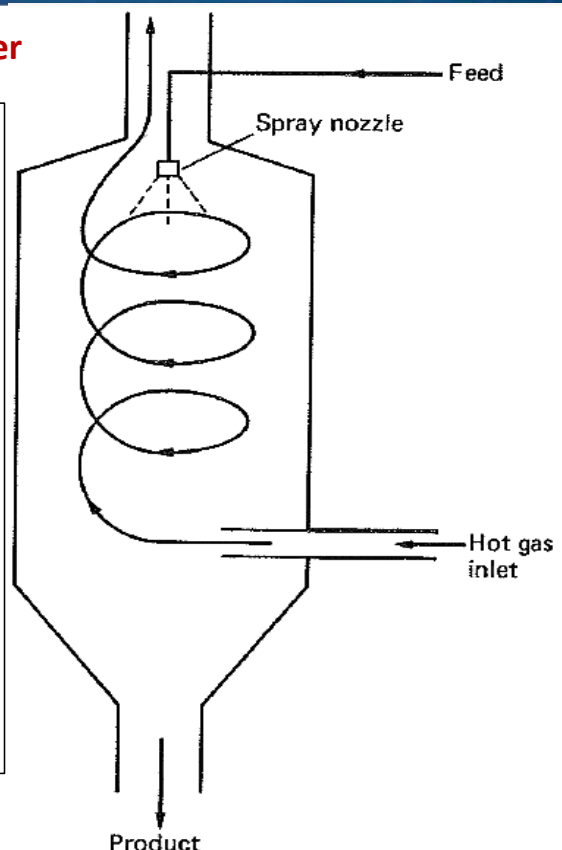

Recovery & Purification of Fermentation Products

Freeze drying is an important operation in the production of many biologicals and pharmaceuticals.

Material is first frozen and then dried by sublimation in a high vacuum. The great benefit of this technique is that it does not harm heat sensitive materials.

Advances in Fermentation Technology

Lesson No.85

Recovery and Purification of Fermentation Products-5

Recovery & Purification of Fermentation Products

Crystallization is an established method used in the initial recovery of organic acids and amino acids, and more widely used for final purification of a diverse range of compounds. In citric acid production, the filtered broth is treated with $\text{Ca}(\text{OH})_2$ so that the relatively insoluble calcium crystals will be precipitated from solution.

The concept of recovering a metabolite directly from an unfiltered fermentation broth is of considerable interest because of its simplicity, the reduction in process stages and the potential cost savings. It may also be possible to remove the desired fermentation product continuously from a broth during fermentation so that inhibitory effects due to product formation and product degradation can be minimized throughout the production phase.

Recovery & Purification of Fermentation Products

Roffler *et al.* (1984) reviewed the use of a number of techniques for the *in-situ* recovery of fermentation products:

1. Vacuum and flash fermentations for the recovery of ethanol from fermentation broths.
2. Extractive fermentation (liquid-liquid and phase aqueous) for the recovery of organic acids and toxin produced by *Clostridium tetani*.
3. Adsorption for the recovery of ethanol and cycloheximide.

Recovery & Purification of Fermentation Products

4. Ion-exchange in the extraction of salicylic acid and antibiotics.

5. Dialysis fermentation in the selective recovery of lactic acid, salicylic acid and cycloheximide.

END

Advances in Fermentation Technology

Lesson No.86

**Effluent
Treatment-1**

Effluent Treatment

Every fermentation plant utilizes raw materials which are converted to a variety of products. Depending on the individual process, varying amounts of a range of waste materials are produced. **Typical wastes might include unconsumed inorganic and organic media components, microbial cells and other suspended solids, filter aids, waste wash water from cleansing operations, cooling water, water containing traces of solvents, acids, alkalis, human sewage, etc.**

Historically, it was possible to dispose of wastes directly to a convenient area of land or into a nearby watercourse. This cheap and simple method of disposal is now very rarely possible, nor is it environmentally desirable.

Effluent Treatment

Water authorities and similar bodies have become more active in combating pollution caused by domestic and industrial wastes.

Legislation in all developed countries now regulates the discharge of wastes.

Effluent Treatment

With liquid wastes, it may be possible to dispose of untreated effluents to a municipal **sewage treatment works (STW)**. Obviously, much will depend on the composition, strength and volumetric flow rate of the effluent. STWs are planned to operate with an effluent of a reasonably constant composition at a steady flow rate. Thus, if the discharge from an industrial process is large in volume and intermittently produced it may be necessary to install storage tanks on site to regulate the effluent flow.

Normally, fermentation effluents do not contain toxic materials which directly affect the aquatic flora or fauna.

Effluent Treatment

Unfortunately, most of the effluents do contain high levels of organic matter which are readily oxidized by microbial attack and so drastically deplete the dissolved oxygen concentration in the receiving water unless there is a large dilution factor.

Effluents may be treated in a variety of ways by a number of processes it may be possible to recover waste organic material as a solid and sell it as a by-product which may be an animal feed supplement or a nutrient to use in fermentation media. The marketable by-product helps to offset the cost of the treatment process.

Effluent Treatment

It is now recognized that water is no longer a cheap raw material, hence there are considerable advantages in reducing the quantities used and in recycling whenever it is feasible.

Advances in Fermentation Technology

Lesson No.87

**Effluent
Treatment-2**

Effluent Treatment

Since oxygen is essential for the survival of most organisms, it is important to ensure that there are adequate levels of dissolved oxygen in rivers, lakes, reservoirs, etc., if they are to be managed satisfactorily.

It is therefore important to know how effluents containing soluble and particulate organic matter can influence the dissolved oxygen concentration. One widely used method of assessment is the 'biochemical oxygen demand' (BOD), which is a measure of the quantity of oxygen required for the oxidation of organic matter in water, by micro-organisms present, in a given time interval at a given temperature.

Effluent Treatment

A complete survey of industrial operations is essential for any individual site before an economical waste treatment programme can be planned.

Factors to investigate in a site survey

- Daily flow rate
- Fluctuations in daily, weekly and seasonal flow
- BOD/COD
- Suspended solids
- Turbidity
- pH range
- Temperature range
- Odours and tastes
- Colour
- Hardness
- Detergents
- Radioactivity
- Presence of specific toxins or inhibitors (e.g. heavy metals, phenolics etc.)

Effluent Treatment

If the survey is comprehensive it should be possible to plan an overall treatment programme for a site and to establish:

1. **Water sources which can be combined or reused.**
2. Concentrated waste streams which contain valuable wastes to be recovered as food, animal feed, fertilizer or fuel.
3. **Toxic effluents needing special treatment, or acids or alkalis needing neutralization.**
4. The effluent loading expected under maximum production conditions.
5. The effluent(s) which might be discharged into municipal sewers.

Effluent Treatment

6. The effluent(s) which might be discharged directly, without treatment, on to land or to a watercourse and not cause any pollution.

Lesson No.88

Effluent Treatment-3

Effluent Treatment

The effluent disposal procedure which is finally adopted by a particular manufacturer is obviously determined by a number of factors, of which the most important is the control exercised by the relevant authorities in many countries on the quantity and quality of the waste discharge and the way in which it might be done. **The range of effluent-disposal methods which can be considered is:**

- 1. The effluent is discharged to land, river or sea in an untreated state.**
- 2. The effluent is removed and disposed of in a landfill site or is incinerated.**

Effluent Treatment

3. The effluent is partially treated on site prior to further treatment or disposal by one of the other routes indicated.
4. Part of the effluent is untreated and discharged as in 1 or 2, the remainder is treated at a sewage works or at the site before discharge.
5. All of the effluent is sent to the sewage works for treatment, although there might be reluctance by the sewage works to accept it, possibly resulting in some preliminary on-site treatment being required, and discharge rates and effluent composition defined.
6. All the effluent is treated at the factory before discharge.

Effluent Treatment

Disposal of Effluents to Sewers

Municipal authorities and water treatment companies which accept trade effluents into their sewage systems will want to be sure that:

1. The sewage works has the capacity to cope with the estimated volume of effluent.
2. The effluent will not interfere with the treatment processes used at the sewage works.
3. There are no compounds present in the effluent which will pass through the sewage works unchanged and then cause problems when discharged into a watercourse.

Effluent Treatment

Fermentation wastes may be treated on-site or at an STW by any or all of the three following methods:

- A. Physical treatment
- B. Chemical treatment
- C. Biological treatment

The final choice of treatment and disposal processes used in each individual factory will depend on local circumstances.

Treatment processes may also be described in the following manner:

1. Primary treatment; physical and chemical methods, e.g. sedimentation, coagulation etc.

Effluent Treatment

2. Secondary treatment; biological methods (e.g. activated sludge) conducted after primary treatment.
3. Tertiary treatment; physical, chemical or biological methods (e.g. microstrainers, sand filters and grass plot irrigation) used to improve the quality of liquor from previous stages.
4. Sludge conditioning and disposal; physical, chemical and biological methods. Anaerobic digestion is often used to condition (make it more amenable to dewatering) the sludge produced in previous stages. Following dewatering (e.g. by centrifugation using a decanter centrifuge) the sludge can then be disposed of by incineration, landfilling, etc.

Effluent Treatment

Most organic-waste materials may be degraded biologically by aerobic or anaerobic processes.

The most widely used aerobic processes are **trickling filters**, **rotating disc contactors**, **activated sludge processes** and their modifications.

Effluent Treatment

The anaerobic processes (**digestion**, **filtration** and **sludge blankets**) are used both in the treatment of specific wastewaters and in **sludge conditioning**.

Lesson No.89

Effluent Treatment-4

Effluent Treatment

❑ Trickling Filters

The term filter in this unit operation is a misnomer, as the action of a trickling filter is not one of filtration, but rather it is a fixed film bio-reactor. **Settled effluent to be treated is passed down through a packed bed counter-current to a flow of air. Micro-organisms adhering to the packing matrix adsorb oxygen from the upflowing air and organic matter from the downflowing effluent; the latter is then metabolized and the effluent stream's BOD reduced.** The effluent trickles gradually through the bed and a slime layer of biologically active material (bacteria, fungi, algae, protozoa and nematodes) forms on the surface of the support material.

Effluent Treatment

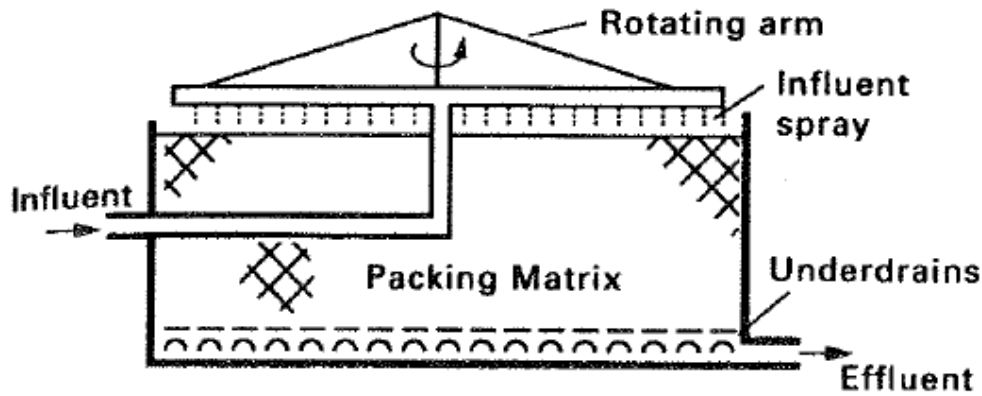

Schematic diagram of a trickling filter

Because trickling filters do not have both a high specific area and a high voidage, they are less suitable for the treatment of large volumes of strong industrial effluents.

Effluent Treatment

Biologically Aerated Filters (BAFs)

Biologically aerated filters are a relatively recent development based on the trickling filter. **They consist of a packed bed which provides sites for microbial growth through which air is passed but, unlike trickling filters, the reactor volume is flooded with the effluent to be treated which is passed upwards or downwards through the reactor.**

The combination of aeration and filtration allows high rates of BOD and ammonia removal together with solids capture, so that sedimentation tanks may not be required.

Effluent Treatment

☐ Activated Sludge Processes

The basic activated-sludge process (Fig. on next slide) consists of aerating and agitating the effluent in the presence of a flocculated suspension of micro-organisms on particulate organic matter - the activated sludge. This process is the most widely used biological treatment process for both domestic and industrial wastewaters.

A number of modifications of the basic process can be used to improve treatment efficiency, or for a more specific purpose such as denitrification. Tapered aeration and stepped feed aeration are used to balance oxygen demand with the amount of oxygen supplied.

Effluent Treatment

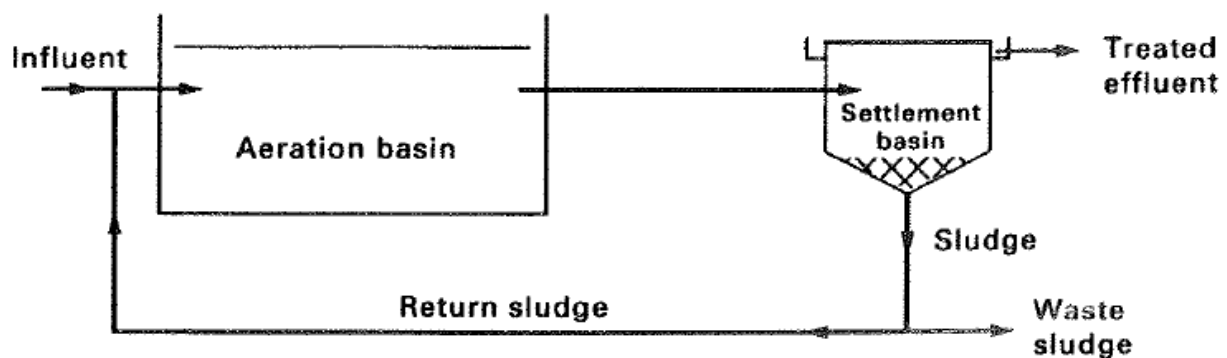

Simplified cross-section of an activated sludge process.

Contact stabilization exploits biosorption processes and thereby allows considerable reduction in basin capacity (50%) for a given wastewater throughput. Denitrification can be accomplished in an activated-sludge plant when the first part of the basin is not aerated.

Effluent Treatment

In advanced activated-sludge systems the amount of dissolved oxygen available for biological activity is increased to improve treatment rate.

Advances in Fermentation Technology

Lesson No.90

**Effluent
Treatment-5**

Effluent Treatment

Anaerobic treatment of waste organic materials originated with the use of septic tanks, which have now been replaced by a variety of high-rate digesters. Loehr (1968) has listed the following reasons for using anaerobic processes for waste treatment:

1. Higher loading rates can be achieved than are possible for aerobic treatment techniques.
2. Lower power requirements may be needed per unit of BOD treated.
3. Useful end-products such as digested sludge and/or combustible gases may be produced.
4. Organic matter is metabolized to a stable form.

Effluent Treatment

5. There is an alteration of water-binding characteristics to permit rapid sludge dewatering.
6. The reduced amount of microbial biomass leads to easier handling of sludge.
7. Low levels of microbial growth will decrease the possible need for supplementary.

Large volumes of wet sludge which are produced in primary and secondary sedimentation tanks may have to be reduced in volume before disposal. **This volume of sludge can be reduced by anaerobic digestion.** In sludges containing 20,000 - 60,000 mg dm⁻³ solid matter, 80% of the degradable matter may be digested, which will reduce the solids content by 50%.

Effluent Treatment

During anaerobic digestion acid fermenting bacteria degrade the waste to free volatile fatty acids, mainly acetic and propionic acid, which are then converted to methane (60%) and carbon dioxide (40%).

The gas produced (**biogas**) is a very useful by-product, and can be burnt as a heating fuel, fed to gas engines to generate electricity or used as a vehicle fuel. As well as being used in sludge digestion and conditioning, anaerobic digesters are also used directly in the treatment of many high strength wastewaters, for example from the food and agricultural industries.

Effluent Treatment

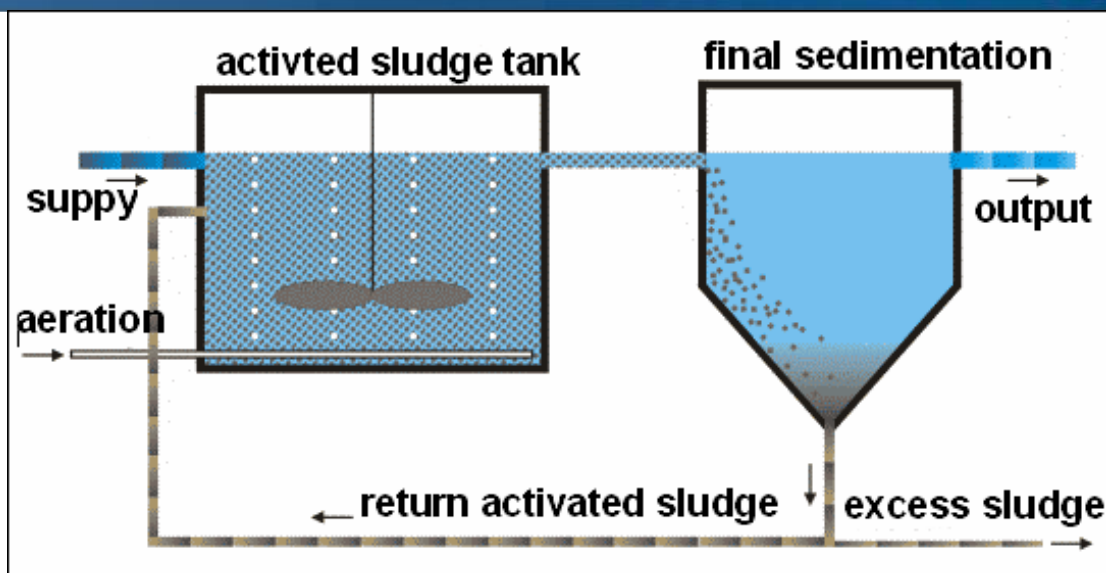

Aeration and Mixing mechanical devices consist of equipment that allow a deeper contact between air and mixed liquor into the tank. Basically, mechanical aerators can be classified into two types: **Mechanical aerators with vertical axis** & **Mechanical aerators with horizontal axis**.

Effluent Treatment

Significant amounts of fossil fuel can be saved in the distillery by generating power and heat from the methane produced during wastewater treatment in cogeneration units and using the generated form of energy within the alcohol production process.

Advances in Fermentation Technology

Lesson No.91

**Fermentation
Economics**

Fermentation Economics

If a fermentation process is to yield a product at a competitive price, the chosen micro-organism or animal cell culture should give the desired end-product in predictable, and economically adequate, quantities. A number of basic objectives are commonly used in developing a successful process which will be economically viable.

1. The capital investment in the fermenter and ancillary equipment should be confined to a minimum, provided that the equipment is reliable and may be used in a range of fermentation processes.

Fermentation Economics

2. Raw materials should be as cheap as possible and utilized efficiently. A search for possible alternative materials might be made, even when a process is operational.
3. The highest-yielding strain of micro-organism or animal cell culture should be used.
4. There should be a saving in labour whenever possible and automation should be used where it is feasible.
5. When a batch process is operated, the growth cycle should be as short as possible to obtain the highest yield of product and allow for maximum utilization of equipment. To achieve this objective it may be possible to use fed-batch culture.

Fermentation Economics

6. Recovery and purification procedures should be as simple and rapid as possible.
7. The effluent discharge should be kept to a minimum.
8. Heat and power should be used efficiently.
9. Space requirements should be kept to a minimum, but there should be some allowance for potential expansion in production capacity.
10. All the above must comply with safety guidelines and regulations.

The consideration of so many criteria means that there may have to be a compromise for the particular set of circumstances relating to an individual process.

Fermentation Economics

The fermentation technologist should be aware of the problem of assessing **market potential**, although he/she may not be primarily involved in collating or assessing the necessary data. **It is necessary to estimate the size of the present and potential market and the increase in demand for a compound.**

Hepner (1978) has examined the factors that determine the feasibility of large-scale ethanol production by fermentation. He considered that ethanol produced by fermentation would only be competitive with synthetic ethanol from crude oil **if the fermentation plant was in an area where cheap supplies of carbohydrate were available.**

Fermentation Economics

Stowell and Bateson (1984) identified a number of factors contributing to these costs:

1. Yield losses, even if only modest, are certain to occur at each stage of the recovery process.

Fermentation Economics

2. High energy and maintenance costs associated with running filtration and centrifugation equipment.

3. High costs of solvents and other raw materials used in recovery and refining of products.

www.vuCtn.com

Good Luck

Regards : Zarva Chaudhary

Admin:

* Zarva Chaudhary *

* Chaudhary Moazzam *

* Laiba Maki *